

AMS-02 Command And Data Handling
Interface Control Document

Revision 05m

Document Number: AMS02-CAT-ICD-R05m

10 December 2004

APPROVAL and SIGNATURE

DOCUMENT NAME:

AMS-02 Command And Data Handling Interface Control Document

Author: Michael H. Capell/MIT

Name and Organization Signature Date

Author: Peter Dennett/PADSOFT, Inc

Name and Organization Signature Date

Author: Alexei Lebedev/MIT

Name and Organization Signature Date

Approved: _____

Name and Organization Signature Date

DOCUMENT CHANGE RECORD

<u>Rev No.</u>	<u>History</u>	<u>Date</u>	<u>Remark</u>
00	Initial review issue	Sep 14, 2002	PAD
01	Review updates by Alexei Lebedev	Sep 15, 2002	PAD
01A	Review by Stan and Paul	Oct 8, 2002	PAD
03a	Addition of content, but not done yet.	Dec 18, 2002 – Mar 21, 2003	PAD
03b	<ul style="list-style-type: none"> • Added subset fields to H&S format • Title change • CDR suggestions applied 	7-May 2003	PAD
03c	<ul style="list-style-type: none"> • General corrections and changes to match PDL. Corrections by MHC. 	2-Aug-2003	PAD
04	<ul style="list-style-type: none"> • Updated Critical Health Data • Defined state codes for commands • Review and comments by M. Capell and A. Lebedev 	Aug-2003	PAD
04a	<ul style="list-style-type: none"> • General edits and clarifications 	Sep-2003	PAD
05	<ul style="list-style-type: none"> • Clarification of command to stream routing and ACOP play operation, including new proposal for APIDs. • CHD introduction • File transfer protocol updated 	Jan-2004	PAD
05d	<ul style="list-style-type: none"> • AMS-02 Activation and Power Steps • File transfer “go” command • OIU Super Formats 	Mar-2004	MHC PAD
05e	<ul style="list-style-type: none"> • More OIU and STS Ground Segment details 	Mar-2004	PAD
05f	<ul style="list-style-type: none"> • ACOP Telemetry details 	Mar-2004	PAD
05g	<ul style="list-style-type: none"> • File transfer protocol description improved • Master Control Task 	Apr-2004	PAD
05i	<ul style="list-style-type: none"> • Verification matrix • Acronyms list • Explanation of NASA responsibility 	May-2004	PAD PN
05l	<ul style="list-style-type: none"> • Joe Breit review • A Lebedev updates • Buddy Hyams review 	Nov-2004	PAD

CONTENTS

1	INTRODUCTION.....	10
1.1	ISS PROGRAM (NASA) RESPONSIBILITIES	10
1.2	RELATED DOCUMENTS	10
1.3	ACRONYMS	11
2	COMMAND AND TELEMETRY TYPES.....	15
2.1	DATA STREAMS.....	15
2.2	AMS-02 HOUSE KEEPING DATA	15
2.3	AMS-02 SCIENCE DATA	16
2.4	CRITICAL HEALTH DATA	16
2.5	AMS-02 GROUND AND CREW COMMANDS.....	16
2.6	AMS-02 COMMAND REPLY DATA	16
2.7	PAYLOAD TO PAYLOAD COMMUNICATIONS DATA.....	17
2.8	ACOP RECORDER DOWNLINK DATA	17
3	AMS-02 CCSDS AND FRAME HEADERS	18
3.1	SUPPORTING DOCUMENTS	18
3.2	INTRODUCTION TO THE FRAME HEADER LAYOUT.....	18
3.3	DEFINITION OF FIELDS IN HEADERS	20
3.3.1	CCSDS Primary Header	20
3.3.2	CCSDS Secondary Header.....	22
3.3.3	AMS Frame Headers And Frame Checksums	25
3.4	APID UTILIZATION.....	28
4	WORD SIZE, ALIGNMENT, AND ORDERING	30
4.1	WORD AND BYTE ORDERING.....	30
4.1.1	For Telemetry From AMS-02 And ACOP	30
4.1.2	For Ground Commands To AMS-02 And ACOP.....	30
4.1.3	For Payload to Payload (AMS-02, ACOP, DDRS2) Commands.....	30
4.1.4	For Commands From PLMDM and PCS to AMS-02 and ACOP.....	30
5	INTRODUCTION TO 1553	31
5.1	GENERAL.....	31
5.2	BUS CONTROLLER (BC).....	31
5.3	REMOTE TERMINAL (RT).....	31
5.4	MESSAGE TYPES	31
5.5	MESSAGE TRANSFERS.....	32
5.6	MODE COMMANDS.....	32
5.7	BROADCAST MESSAGES.....	33
6	INTRODUCTION TO HRDL ON ISS.....	34
6.1	HRDL PROTOCOL AND FRAMING.....	34
6.2	KNOWN PROBLEMS WITH HRDL.....	35
6.2.1	Incorrect HRFM MPDU First Header Pointer.....	35
6.2.2	Maximum Contiguous Data Transfer	35
6.2.3	Distribution Of Sync Symbols	35
6.2.4	Fail to Lock-On State by APS.....	35
6.3	TELEMETRY DATA RATE MANAGEMENT	36
6.4	PHYSICAL MEDIA	36
7	STS COMMAND AND TELEMETRY IMPLEMENTATION.....	37
7.1	STS OIU 1553 INTERFACE UTILIZATION	37
7.1.1	1553 House Keeping (Down Link).....	37
7.1.2	OIU/PDI 1553 Data Layout Implementation Details	40
7.1.3	OIU PDI Frame Formats.....	41
7.1.4	1553 Commanding (Up Link)	44
7.1.5	1553 Command Data Layout Implementation Details.....	44
7.1.6	Command Replies.....	47
7.1.7	Time Distribution	47
7.1.8	Mode Commands.....	47

7.1.9	AMS Sub-Address Assignments For OIU Interface.....	48
7.2	STS RS422 LINK UTILIZATION.....	49
7.2.1	Attached Sync Marker (ASM).....	49
7.2.2	Pseudo-Randomization.....	50
7.2.3	RS422 Data Layout Implementation Details.....	50
7.3	STS KU LINK.....	52
7.4	STS DDRS2 LINK.....	52
7.4.1	DDRS2 Data Recording and Monitoring.....	52
7.4.2	DDRS2 Crew Commanding.....	52
8	ISS AMS-02 COMMAND AND TELEMETRY IMPLEMENTATION.....	53
8.1	ISS AMS-02 LRDL (1553) UTILIZATION.....	53
8.1.1	Down Link Telemetry (House Keeping Data).....	53
8.1.2	Commanding (Up Link Telemetry).....	56
8.1.3	PLMDM 1553 Command Data Layout Implementation Details.....	56
8.1.4	Time Distribution.....	58
8.1.5	ISS Time Management.....	59
8.1.6	Broadcast Ancillary Data.....	60
8.1.7	Critical Health Data.....	60
8.1.8	Mode Commands.....	60
8.1.9	PLMDM Sub-Address Assignments.....	61
8.2	ISS AMS-02 HRDL UTILIZATION.....	62
8.2.1	HRDL Protocol and Framing.....	62
8.2.2	AMS-02 HRDL Transmissions.....	63
8.2.3	AMS-02 HRDL Reception.....	63
8.2.4	AMS-02 HRDL Data Layout Implementation.....	63
9	ISS ACOP TELEMETRY IMPLEMENTATION.....	65
9.1	COMMUNICATIONS WITH THE RIC.....	65
9.2	EXPRESS SYNC AND HEADER.....	66
9.3	ACOP COMMANDING.....	67
9.4	ACOP HEALTH AND STATUS DATA.....	68
9.5	ACOP HRDL UTILIZATION.....	70
9.6	ACOP MRDL UTILIZATION.....	70
9.7	ACOP TIME SYNCHRONIZATION.....	70
10	KSC PHASE GROUND SEGMENT INTERFACES.....	72
10.1	1553 SUPPORT.....	72
10.2	RS422 SUPPORT.....	72
10.3	LAUNCH COMMIT CRITERIA.....	73
11	STS PHASE GROUND SEGMENT INTERFACES.....	74
11.1	JSC CUSTOMER INTERFACE PANEL (CIP).....	74
11.2	LOW RATE FRONT END PROCESSOR (LR-FEP).....	75
11.2.1	AMS-02 Health and Status via STS OIU.....	75
11.2.2	Customer Auxiliary Service (CAS).....	75
11.2.3	Command Data.....	75
11.2.4	Command Acceptance Patterns.....	77
11.3	HIGH RATE FRONT END PROCESSOR (HR-FEP).....	78
11.3.1	AMS-02 Science Data Via STS KU-Band.....	78
12	ISS PHASE GROUND SEGMENT INTERFACES.....	79
12.1	MSFC – HOSC.....	79
12.1.1	FSE At HOSC.....	79
12.1.2	TReK Interfaces To HOSC.....	79
13	COMMANDS FOR AMS-02.....	81
13.1	EXTERNALLY DEFINED AMSBLOCKS.....	81
13.1.1	Startup Notification AMSBlock.....	81
13.1.2	Shutdown Notification AMSBlock.....	81
13.1.3	Operations Standby AMSBlock.....	82
13.1.4	Magnet Watch Dog Set AMSBlock.....	82
13.1.5	Set Power Step AMSBlock.....	82

13.1.6	Set Operation Condition AMSBlock	83
13.1.7	Set Telemetry State AMSBlock	84
13.1.8	Set Owners AMSBlock	84
13.1.9	Set Parameter_1 AMSBlock	85
13.1.10	Set Parameter_2 AMSBlock	85
13.1.11	Set Parameter_3 AMSBlock	85
13.1.12	Set Parameter_4 AMSBlock	86
13.1.13	Set Parameter_5 AMSBlock	86
13.1.14	Ping Node	86
13.1.15	Boot Node	87
13.1.16	Set Heaters	88
13.2	PDL DEFINED EXTERNAL COMMANDS	88
13.3	PDL DEFINED STANDARD POCC COMMAND	88
13.4	COMMAND FRAMING	88
13.4.1	PLMDM Issues	88
13.4.2	OIU Issues	88
13.4.3	HRDL Issues	88
14	ACOP MASTER CONTROL TASK (MCT).....	89
14.1	ACOP MCT AMSBLOCK INTERFACE SECONDARY HEADER	89
15	AMS-02 ACTIVATION – POWER STEPS.....	90
16	MAGNET CHARGING OPERATIONS	94
17	FILE TRANSFER PROTOCOL.....	95
17.1	FILE SYSTEM STRUCTURE AND SYMBOLIC FILE NAMES	95
17.2	AMSBLOCK - FILE TRANSFER START	95
17.2.1	Write Operation Format	95
17.2.2	Read Operation Reply Format	97
17.3	AMSBLOCK - FILE SECTOR	98
17.3.1	Write Operation Format	98
17.3.2	Read Operation Reply	99
17.4	DOWNLINK REPLY FORMAT	99
17.5	FILE TRANSFER PROTOCOL SEMANTICS	99
17.5.1	Uplink of Files	99
17.5.2	Downlink of Files	101
17.6	TRANSFER TIMEOUTS.....	101
17.7	AMSBLOCK FILE SYSTEMS OPERATIONS	101
17.7.1	Write Operation Request.....	101
17.7.2	Read Operation Reply.....	103
18	CRITICAL HEALTH DATA	104
18.1	BACKGROUND	104
18.2	INTRODUCTION.....	104
18.3	CHD FORMAT	105
18.3.1	Time Division Multiplex (TDM) Values.....	108
18.3.2	TDM Indirection Table.....	109
19	AMS BLOCK FORMAT.....	111
19.1	BLOCK LENGTH.....	111
19.2	AMS BLOCK HEADER	111
19.2.1	AMS Block BLKTYP - Block Type	112
19.2.2	AMS Block NodeAddress.....	112
19.2.3	AMS Block DataType	112
19.2.4	Required Data Types	115
19.2.5	Common Data Types	116
20	AMS BLOCK FRAMING.....	117
20.1	CONSTRUCTING FRAMES FROM AMSBLOCKS	117
20.2	AMSBLOCK SECONDARY HEADERS.....	117
20.2.1	Uplink Requests (Commands).....	117
20.2.2	Downlink Relies (Telemetry).....	117
20.3	DE-FRAMING AMSFRAMES.....	118

21	AMS BLOCK ENVELOP ENCAPSULATION.....	119
21.1	ENVELOP ENCAPSULATING AN AMSBLOCK.....	119
21.2	ENVELOP ENCAPSULATING AN AMSWIRE BLOCK.....	119
21.3	ENVELOP ENCAPSULATING AN AMS CAN BLOCK.....	120
22	AMS-02 PATH ADDRESSING.....	121
23	NODE ADDRESSES.....	122
23.1	JMDC ADDRESSES	122
23.2	SLOW CONTROL ADDRESSES	122
23.3	JINJ AND TRIGGER ADDRESSES	124
23.4	DAQ ADDRESSES	124
24	HEX DUMP OF COMMAND FROM STEP.....	129
25	HEX DUMP OF OIU HEALTH AND STATUS.....	130
26	PAYLOAD DATA LIBRARY REPORTS – COMMANDS.....	131
27	PAYLOAD DATA LIBRARY REPORTS – TELEMETRY.....	134
28	VERIFICATION MATRIX.....	135

TABLE OF FIGURES

Figure 1 ACOP Play APID Transformation	17
Figure 2 AMS Frame Header Layout	19
Figure 3 CCSDS Primary Header	21
Figure 4 CCSDS Secondary Header	25
Figure 5 AMS Frame Headers And Frame Checksums.....	27
Figure 6 APID Symbolic Values	29
Figure 7 High Rate Data Link Design	34
Figure 8 OIU Bus Topology	37
Figure 9 OIU Frame Concept	39
Figure 10 OIU/PDI HK 1 st 1553 Sub Address Block.....	40
Figure 11 OIU/PDI Implementation Notes.....	41
Figure 12 Start of AMS-02 Data within PDI Frames	41
Figure 13 PDI Frame Layouts.....	42
Figure 14 PDI Data Field Details.....	42
Figure 15 OIU Health and Status.....	43
Figure 16 1 st Sub Address Block For AMS Command Via OIU.....	45
Figure 17 2 nd Sub Address Block For AMS Command Via OIU.....	46
Figure 18 Values in Commands Via OIU.....	46
Figure 19 OIU Broadcast Time Format.....	47
Figure 20 AMS Mode Code Implementation For OIU.....	48
Figure 21 1553 Sub-Address Assignments For OIU Interface.....	49
Figure 22 RS422 Data Layout	51
Figure 23 ISS House-Keeping Data Format	55
Figure 24 Values in ISS House-Keeping Data Format.....	56
Figure 25 PLMDM Command 1 st 1553 Sub Address Block.....	57
Figure 26 PLMDM Command 2 nd 1553 Sub Address Block	58
Figure 27 PLMDM Broadcast Time Format	59
Figure 28 AMS Mode Code Implementation For PLMDM.....	61
Figure 29 PLMDM Address Assignments	62
Figure 30 HRDL Data Layout Implementation.....	64
Figure 31 Ethernet Data Layout.....	65
Figure 32 EXPRESS Header	66
Figure 33 EXPRESS Header Message Types.....	67
Figure 34 Ground to RIC to ACOP Command Layout	67
Figure 35 EXPRESS Command Envelop	68
Figure 36 ACOP Health and Status Layout.....	69
Figure 37 ACOP Time Request.....	70
Figure 38 RIC Time Response.....	71
Figure 39 KSC Ground Interfaces	72
Figure 40 STS Phase POCC Connections	74
Figure 41 OIU Command Envelop	76
Figure 42 OIU Command Envelop Values.....	77
Figure 43 OIU Parity Example	77
Figure 44 ISS Ground Segment.....	79
Figure 45 Startup Notification AMSBlock.....	81
Figure 46 Shutdown Notification AMSBlock	82
Figure 47 Operations Standby AMSBlock.....	82

Figure 48 Magnet Watch Dog Set AMSBlock	82
Figure 49 Set Power Step AMSBlock	83
Figure 50 Power Step State Codes	83
Figure 51 Set Operations Condition AMSBlock	83
Figure 52 Operation State Codes	84
Figure 53 Set Telemetry State AMSBlock	84
Figure 54 Telemetry State Codes	84
Figure 55 Set Owners AMSBlock	85
Figure 56 Set Parameter_1 AMSBlock	85
Figure 57 Set Parameter_2 AMSBlock	85
Figure 58 Set Parameter_3 AMSBlock	86
Figure 59 Set Parameter_4 AMSBlock	86
Figure 60 Set Parameter_5 AMSBlock	86
Figure 61 Set Parameter_5 AMSBlock	87
Figure 62 Boot Command Fields Checked	87
Figure 63 CHD Layout	106
Figure 64 Critical Health Data Format	108
Figure 65 TDM Field Values	109
Figure 66 TDM Indirection Table	110
Figure 67 Normal AMS Block Length	111
Figure 68 Extended AMS Block Length	111
Figure 69 Normal Block Header	111
Figure 70 Extended Block Header	112
Figure 71 AMS Block Type	112
Figure 72 Data Types Every Node Must Provide	115
Figure 73 Command Data Types Any Node Can Provide	116
Figure 74 PDL Commands	131
Figure 75 PDL Command Fields	133
Figure 76 PDL Telemetry Fields	134
Figure 77 Health and Status Subset Fields	134
Figure 78 Verification Matrix	136

1 Introduction

This document presents the formats and strategies for AMS-02 command and data handling during its three-year mission to ISS and during on-orbit check-out in the STS.

1.1 ISS Program (NASA) Responsibilities

AMS-02 is a Department of Energy sponsored payload for which NASA is providing integration, delivery, and ISS accommodations. The sponsorship is defined by a signed Memorandum Of Understanding (MOU) (dated September 20, 1995) that states DOE is responsible for submission of data required for “Interface, integration and safety data” only. NASA is not responsible for mission success and provides minimal avionics support systems. This document attempts to present a broad enough cross section of information about the AMS-02 avionics interfaces to various NASA systems that NASA may understand both the intent and the impact of the AMS-02 design. This does not imply that NASA has responsibility for this design.

Under this Command and Data Handling ICD it is assumed that NASA shall:

1. Deliver AMS-02 commands as presented by the AMS-02 POCC to NASA data systems at JSC or MSFC to the on orbit AMS-02.
2. Provide the ability to deliver a small number of predefined commands, with simple integer parameters, from NASA systems (both ground and on orbit) to the on orbit AMS-02.
3. Provide the ability to display and monitor the AMS-02 Critical Health Data (CHD) via NASA systems ground equipment.
4. Provide the delivery of the CHD from S-Band transmissions to the AMS-02 POCC.
5. Deliver, unmolested and un-interpreted, the AMS-02 Health and Status data created by the on orbit AMS-02 to the AMS-02 POCC.
6. Deliver, unmolested and un-interpreted, all other AMS-02 APID data streams created by the on orbit AMS-02 to the AMS-02 POCC.

1.2 Related Documents

Title	Revision and Date	Document #	Comments
Payload Support Capabilities Description: MCC, JSC POCC, Remote POCC Interface	Rev. E August 16, 2003	NSTS- 21063- POC-CAP	
User's Guide for the	Aug 1997	JSC 27669	

Orbiter Interface Unit (OIU)			
Payload Software Interface Control Document Template	Rev. C Draft Dec 13, 2002	SSP 57002C	
EXpedite the PROcessing of Experiments to Space Station (EXPRESS) Rack Payloads Interface Control Cocument	Rev E September 9, 2003	SSP 52000-IDD-ERP	

1.3 Acronyms

1553	A serial data link with multi-drop addressing.
A/D	Analog to digital
ACOP	AMS-02 Crew Operations Post (ACOP). A general purposed computer system located within the ISS pressure volume used to record AMS-02 science data and provide an operations post for the ISS crew.
AMSBlock	Granularity of data for command and telemetry systems. Contains one or more data point.
AMSFrame	A logical blocking for physical transmission of AMSBlocks.
AMSWire	100Mbit/second serial point to point connection.
APID	Application Process ID.
APS	Automated Payload Switch. An ISS facility that provides cross bar switching for HRDL connections.
ASM	Attached Sync Marker
BC	Bus Controller. The master of the 1553 bus. Also: Bus Coupler. A interface device consisting of transformers to connect to a 1553 bus.
BM	Bus Monitor. A mode of operation for a 1553 device
CAN	Controller Area Network. Provides robust low speed serial communications on a bus.
CDDC	Command Distributor Data Concentrator. Passes commands from the MDC down the DAQTree. Concatenates event data and passes it and other data up the DAQTree. There are two levels of CDDCs called JINJ and JINF.
CDP	Common Digital Part - A common design element in AMS based on a Digital Signal Processor chip, Program FLASH, SRAM, and AMSWire interface
CHD	Critical Health Data
DAQ	Data acquisition (system)
DAQTree	The Data Acquisition (DAQ) system is organized in a tree structure. Each node of the tree processes and buffer portions of the event data.
DDRS	Digital data recording system
ECW	Error and Caution Word
EM	Engineering Model. Pre-FM designs.
EVA	Extra Vehicular Activity (Space Walk)

EVA Connector	Space qualified connector suitable for handling by an astronaut while space walking
EVA Panel	An interface to the ISS avionics.
Event	When a candidate particle creates a trigger signal this is an event. The data sampled from the detectors is called the event data.
Event Builder	The software on the MDC the completes the assembly of an events data.
EXPRESS	EXpedite the PROcessing of Experiments to the Space Station
FLASH	Re-programmable non-volatile memory
FM	Flight Model.
FPGA	Field programmable gate array
Front End	The electronics interfacing detectors and the DAQ system
FS	Flight Spare.
FSE	Flight Support Equipment. Equipment used to support AMS-02 during operations in flight.
GDAQ	Global Data Acquisition system. The facilities used to acquire the AMS-02 data.
GPS	Global Positioning System. Provides accurate time and position.
Ground Segment	The collection of FSE used to support AMS-02.
GSE	Ground Support Equipment. Equipment used to support AMS-02 during operations on the ground.
HOSC	Huntsville Operations Support Center. The NASA facility providing operations support for ISS. Located at MSFC.
H&S	Health and Status
HRDL	High Rate Data Link. A fiber optic serial link based on TAXI (FDDI) protocol. It is the backbone of the ISS telemetry system.
ISS	International Space Station.
IP	Internet Protocol
JBP	J-Crate Backplane
JBU	A 2Gbyte buffer used to buffer the AMS data to be sent to the ground.
J-Crate	The electronics crate containing the MDCs and interfaces to the ISS.
JFOM	Fiber optic Multiplex module
JHIF	J-Crate high rate interface board
JIM	JMDC Interface module board
JIM_AMSW	The J-Crate interface to the AMSWire links.
JIM_HRDL	The J-Crate interface to HRDL links.
JLIF	J-Crate low rate interface board
JMDC	Main DAQ computer (AKA MDC)
JPD	J-Crate Power Distributor
JSBC	JMDC Single board computer
JSC	Johnson Spacecraft Center
KSC	Kennedy Space Center
KU	The radio telemetry system used for high volume communication with earth. Also KU-Band.
Latch-up	A heavy ion cosmic ray radiation induced failure of a circuit some times resulting in excessive power consumption and circuit destruction
Levell	The trigger front-end that determines when an event is to be collected.

Level3	The Level3 Trigger suppresses events that are not of interest or malformed.
LRDL	Low Rate Data Link. A dual redundant 1553 bus.
MCT	Master Control Task. Software within MDC to provide general on-board commanding services.
MCC-H	Mission Control Center – JSC Houston. Command and control center for ISS.
MDC	The Main Data Computer (or Main DAQ Computer) completes assembly of the event data, suppresses uninteresting events, buffers the event data and organizes its transmission to the ground. The MDC also acts as the command and control system for AMS-02.
MRDL	Medium Rate Data Link (802.3)
MSFC	Marshall Space Flight Center. Located in Huntsville Alabama.
OIU	Orbiter Interface Unit. The bus master of 1553 on STS
Orbiter	Space shuttle
PCI	Peripheral Component Interconnect
PCI Agent	FPGA based cPCI interface to local peripherals
PDL	Payload Data Library
PDS	Power Distribution System. The fuse box of AMS-02. (AKA PDB)
PDIP	Payload Data Interface Panel. A panel on the aft flight deck of STS
PLMDM	Payload Multiplexer/De-multiplexer. Serves as the 1553 bus master. Provides routing for commands to payloads and reads telemetry (health and status) for downlink.
PMT	Photo Multiplier Tube
POCC	Payload Operations Control Center. Where AMS-02 monitoring control occurs.
POIC	Payloads Operation and Integration Center. Located at MSFC.
PRO	Payload Rack Officer. POIC person who supervises MSFC involvement with AMS-02. The PRO can issue certain predefined commands on the “PRO’s Console”.
PROM	Programmable Read Only Memory. Commonly infers one time programming
QM	Qualification Model. Built to same specifications as FM but limits are exceeded during testing.
RIC	Rack Interface Controller
ROEU	Remotely Operated Electronics Umbilical. Connector between AMS-02 and STS
ROM	Read Only Memory. Most often means PROM
RS422	In fact an electrical standard specifying signaling on a single twisted pair. Used in the context here to specify a serial data stream protocol carried over several RS422 twisted pairs.
RT	Remote Terminal. A 1553 device which accepts transactions from the bus controller (BC).
RTFM	Read The Fine Manual
SOC	Science Operations Center. Where the recording of AMS-02 science data occurs.
StarTRK	Star Tracker. Provides accurate pointing information based on a star map.
STS	Space Transportation System. Shuttle.

T-0	Time minus zero. AKA launch time. A time proceeding the completion of this document.
TCP	Transmission Control Protocol
TDRSS	Tracking & Data Relay Satellite System. Three satellites, two of which are active, providing communications with ISS and STS.
TRIGGER	Control logic that first detects that a candidate particle has passed thru the detector. This asserts signals requesting the orderly readout and flags the readout system as busy. Also known as the Level1 trigger.
Trigger	Electronics associated with detecting passage of a particle based on detector activity. Also used to describe software based filtering of observed events
UMA	Umbilical Mechanism Assembly. Connector between AMS-02 and ISS
USCM	Universal Slow Control Module. Single board computer interfacing to dual CAN buses and providing measurement and control.
USLAB	The United States Laboratory module on ISS.
White Sands	The location in New Mexico that receives KU-Band telemetry from the TDRSS.
xDR	Detector Data Reduction. The board implementing the CDP for a detector.
xDR2	A class of Data Reduction boards for front ends with two CDPs on board

2 Command and Telemetry Types

All AMS-02 commands and telemetry, except the Critical Health Data, are composed of AMS Blocks. An AMS Block represents a particular set of data from a particular node within the AMS-02 system (more details later in this document).

The remainder of this section describes the types of data that exist in the AMS-02 system and their organization into streams.

2.1 Data Streams

Typically AMS Blocks of a type are gathered together to form streams of data.

A stream is a "virtual channel" within a data link. Consecutive frames on the link do not necessarily correspond to consecutive blocks within a stream.

The sender of a stream constructs frames of consecutive AMS Blocks into the stream. At an appropriate time (for this particular stream) these frames are transmitted on the data link. Other senders of streams are behaving in a similar fashion and emitting frames for transmission based on their particular needs. The result on the data link is interleaved AMS Frames for differing streams.

The receiver on the data link has to de-interleave the streams, and can then de-frame a stream back into AMS Blocks.

Data streams are used so that it is obvious what the sort of data is contained in a stream of AMS blocks. This allows the prioritization of the de-framing of blocks on a per stream basis.

It must be clearly understood that there is no fixed mapping of AMS Blocks to a particular stream and in fact any particular AMS Block can occur in any, many, or no streams.

NASA assigned "Application Process Ids" - APID numbers are used to identify and route AMS Streams.

Most stream types have only a single manifestation. Some stream types (like house keeping) may be manifested on more than one interface.

The actual streams defined are enumerated in Section 3.4.

2.2 AMS-02 House Keeping Data

AMS-02 produces data indicating the state of most components within the experiment. This includes measured observations such as voltages, pressures, and temperatures, performance statistics, detector operational information, and other information needed to assess the condition of the experiment.

The proper operation of AMS-02 requires near real time ground access to all of this data.

The NASA culture would call this data “health and status”.¹ Typically in the NASA culture H&S data is constructed of rigidly defined major and minor frames with fixed locations for sampled values. This is not possible in AMS-02 due to the large number sampled items and the diverse timing needs for the sampling. Within AMS-02 the AMSBlock is used to organize sets of data.

2.3 AMS-02 Science Data

The purpose of AMS-02 is to gather observations of particles entering its detectors. The observations from one such particle is called an event. The frequency of events varies considerably based on acceptance algorithms which control the trigger, natural phenomena, and orbital position. The data size of each event varies significantly upon the type or nature of the observation.

AMS-02 has considerable buffering abilities used to average the event data rates to the targeted 2Mbits/second average output rate. The successful gathering of science from AMS-02 requires near real time access to at least a statistical sampling of this data. This quality control sample is used to provide calibration and tuning for the detectors.

2.4 Critical Health Data

AMS-02 is always “safe without services” toward the ISS facility and crew but certain conditions can impair mission success. The Critical Health Data is an AMS-02 summary of the health of the experiment. This data is not in the ISS standard caution and warning format and is not intended for use within the PLMDM C&W environment. The critical health data summarizes temperature, voltage, and other measurements into the fewest possible bits for inclusion with the ISS S-Band data.

The proper operation of AMS-02 requires as continuous as possible near real time access to this data. To resolve most anomalies reported by the Critical Health Data will require access to the entire AMS-02 House Keeping Data stream.

2.5 AMS-02 Ground and Crew Commands

AMS-02 requires direction from its ground controllers to operate. The commands will originate from both the AMS-02 POCC and NASA systems (JSC and/or HOSC).

Additionally a means for crew commanding has been provided. On ISS crew commands originate either from ACOP (by front panel buttons or by GUI software on the rack laptop) or the ISS laptop associated with the PLMDM servicing AMS-02. During checkout on STS crew commands can originate from the Digital Data Recording System 2 (DDRS2).

2.6 AMS-02 Command Reply Data

All commands (AMSBlock requests) to AMS-02 result in a (AMSBlock) reply. Each command has an associated reply stream and interface. For ground, DDRS2, and ACOP commands the reply is returned on the interface on which the command

¹ The ISS cadre often just calls it “APID 876 data” which is the APID for the assembled health and status data of all ISS payloads.

arrived (to the appropriate stream). For internal tasks (like the Master Control Task (MCT)) the interface and stream to reply on must be specified. See Section 3.4 for information on a mapping of replies to streams.

2.7 Payload to Payload Communications Data

AMS-02 requires full time, full duplex communication with its pressure volume support systems DDRS2 and ACOP. Since the data volumes in both directions are substantial it is only foreseen to utilize the high-speed links, RS422 and HRDL, for these communications. No usage of payload-to-payload commanding via 1553 is foreseen.

Payload-to-payload communications are implemented as paired command/reply streams on the appropriate high-speed link.

2.8 ACOP Recorder Downlink Data

ACOP records all data it receives from AMS-02 to hard drives. Nominally this would include the streams for AMS-02 Science Data and the AMS-02 Housekeeping data. ACOP can be commanded to Play BaCK (PBCK) to the downlink systems selections of the recorded data. When commanded to play back a selection of data, ACOP transforms the CCSDS header APID (see Section 3.4) in each AMSFrame using the table below.

Original APID	Transformed APID
AMSHK	PBCKHK
AMSSCI	PBCKSCI

Figure 1 ACOP Play APID Transformation

AMSFrames with APIDs not shown in this table are not included in the play operation. This transformation allows the ground data recorders to differentiate “live” and “recorded” streams.

3 AMS-02 CCSDS and Frame Headers

3.1 Supporting Documents

The document SSP57003 “International Space Station Program Attached Payload Interface Requirements Document” levies requirements on AMS-02. This document defers the definitions for CCSDS headers to SSP52050 “SOFTWARE INTERFACE CONTROL DOCUMENT PART 1, INTERNATIONAL STANDARD PAYLOAD RACK TO INTERNATIONAL SPACE STATION”. This document in turn refers the base definitions of CCSDS headers to SSP41175-2 “SOFTWARE INTERFACE CONTROL DOCUMENT STATION MANAGEMENT AND CONTROL TO INTERNATIONAL SPACE STATION BOOK 2, GENERAL SOFTWARE INTERFACE REQUIREMENTS”.

Used to prepare this document:

SSP57003 Version A Aug 5, 2002
SSP52050 Revision E Nov 12, 2002
SSP41175-2 Revision F Mar 1, 2002

3.2 Introduction To The Frame Header Layout

This introduction provides common background on the headers for AMSFrames. Due to unique requirements of some interfaces the actual details of frame headers vary slightly.

All AMS-02 data communicated externally is transmitted and received as AMS Frames of data. Each AMS Frame begins with a set of CCSDS and AMS headers. The CCSDS system has two headers, a required primary header and an optional (but required by NASA in most cases) secondary header. AMS-02 attaches a required AMS Primary Frame Header after the CCSDS header(s) and optionally an AMS Secondary Frame Header.

The CCSDS headers and AMS-02 data are organized in terms of 16-bit words. The following table introduces the various values within the AMS Frame headers. The details of implementation of these headers, and data layouts, are addressed later on a per interface basis.

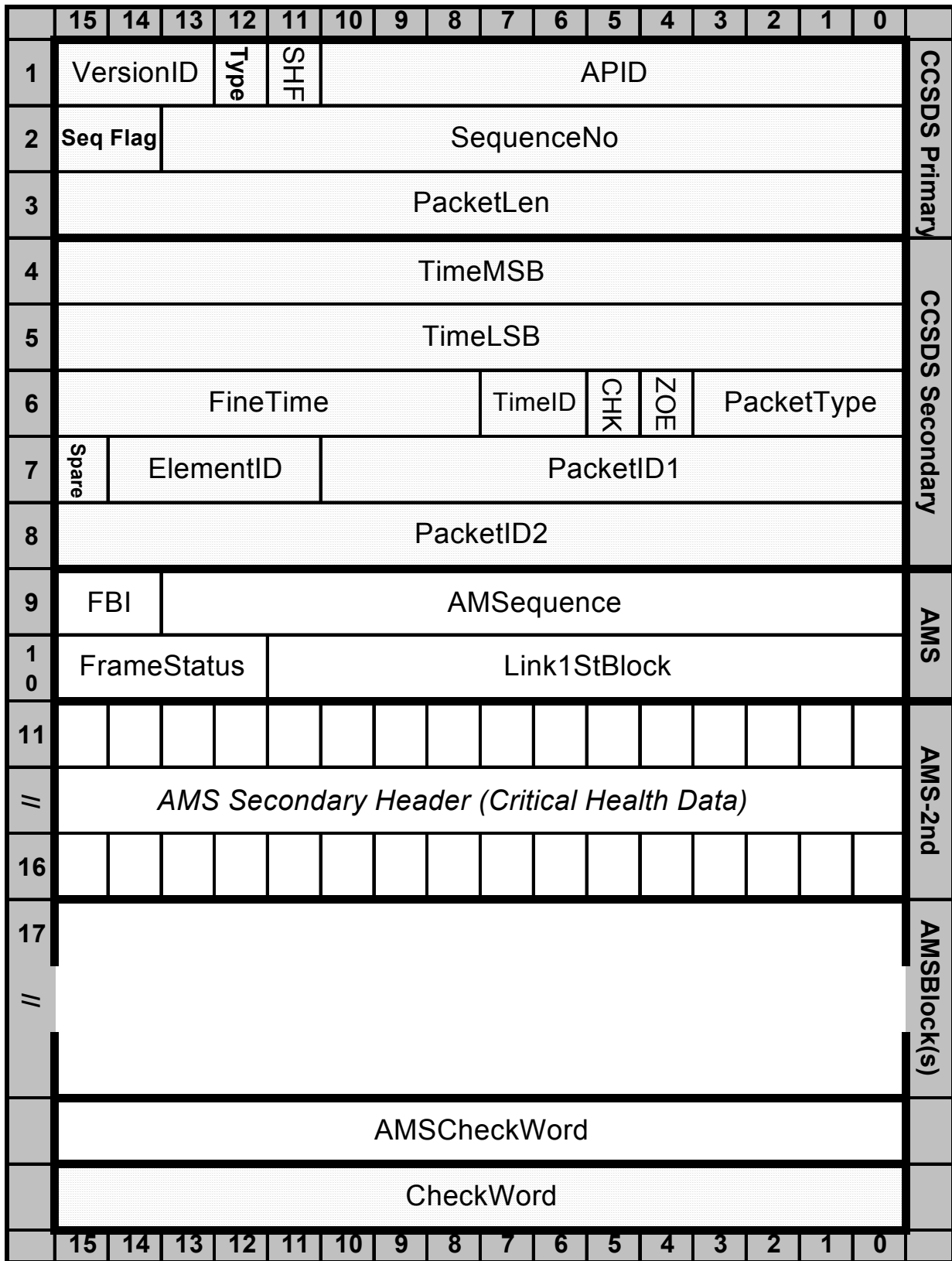

Figure 2 AMS Frame Header Layout

3.3 Definition of Fields in Headers

These tables define the valid values, the values AMS-02 utilizes, and comments on the purpose of each field.

3.3.1 CCSDS Primary Header

Item	Valid Values	AMS-02 Usage for frames received	AMS-02 Usage for frames transmitted	Comment
Location ²				
VersionID 1.15.3	0	0 - Ignored.	0	Version number for CCSDS packet format (does not change)
Type 1.12.1	0: Core 1: Payload	1 - Ignored.	1	Distinguishes between core and payload packet types to extend the APID space to 4032
SHF 1.11.1	1: Present 0: Not present	1 - On receipt is honored.	1	Indicates whether, or not, a Secondary Header follows the primary header. Currently required (always set to 1). However, AMS-02 supports this value being 0 or 1 on all interfaces.
APID 1.10.11	0 – 2031	As assigned by NASA. See Section 3.4 Frames received with invalid APIDs are an error and will be ignored	As assigned by NASA, usage as defined within this ICD.	Application Process ID. Used to determine the data path by NASA and the data stream by AMS-02.

² This area contains the word.start-bit.number-bits

Item	Valid Values	AMS-02 Usage for frames received	AMS-02 Usage for frames transmitted	Comment
Location ²				
SeqFlag 2.15.2	0b00: Continuation 0b01: First segment 0b10: Last segment 0b11: Un-segmented	0b11 - Ignored.	0b11	Must be 0b11 for KU system
SequenceNo 2.13.14	0 – 16383	Used for de-framing of frames received to detected number of lost or missing blocks.	For frames generated this is a sequence within each APID (stream).	Sequential count which numbers each packet on a Logical Data Path, i.e., a separate counter is maintained for each source-destination pair (APID)
PacketLen 3.15.16	0 – 65535	0 – 4084	0-4084	The length of the remainder of the CCSDS packet including CheckWord if present. The value is the number of bytes (octets) following this field minus 1.

Figure 3CCSDS Primary Header

3.3.2 CCSDS Secondary Header

Item Location ³	Valid Values	AMS-02 Usage for frames received	AMS-02 Usage for frames transmitted	Comment
TimeMSB 4.15.16	0 – 65535	Most significant 16 bits of time in seconds.	Most significant 16 bits of time in seconds. The value placed here is the ISS broadcast time as found on the 1553 interface. See sections 7.1.7 and 8.1.4	The time value represents the elapsed time since midnight 5-6 January 1980. The least significant bit (LSB) of the least significant octet of coarse time is equal to 1 second.
TimeLSB 5.15.16	0 – 65535	Least significant 16 bits of time in seconds.	Least significant 16 bits of time in seconds	See above.
FineTime 6.15.8	0 – 255	Ignored	Best effort sub-second time of frame generation.	The LSB of this field is equal to 2^{-8} second or about 4 ms

³ This area contains the word.start-bit.number-bits

Item Location ³	Valid Values	AMS-02 Usage for frames received	AMS-02 Usage for frames transmitted	Comment
TimeID 6.7.2	0b00: Time not used 0b01: Cmd auth or data 0b10: Time tag cmd 0b11: Not used	0b01 - Ignored.	0b01	The time field is always present. This field indicates its use. For Data Packets, the field is always 0b01 and the time fields contain the time at the beginning of the processing frame when the packet was generated. Other values are for command processing, unused by AMS.
CHK 6.5.1	0: Not present 1: Present See comments.	1 - If present in received frames the last word of the frame is not considered to be AMS data. It must be checked. Commands with invalid check words are ignored.	0	This field indicates if a CheckWord (16-bit add without carry checksum) is contained in the CCSDS packet. When present, the CheckWord is the last 16-bit word of the packet. All commands must contain a CheckWord. Data packets do not require a CheckWord.
ZOE 6.4.1	0: Frame from onboard ZOE recording 1: All others	0 - Ignored.	0	Used in a telemetry data packet to indicate that the telemetry packet is from the onboard ZOE recording (HCOR, etc).
PacketType 6.3.4	0b0001: Data dump 0b0100: Telemetry 0b0110: Private Sci 0b0111: Ancillary 0b1000: Ess Cmd 0b1001: Sys Cmd 0b1010: RT/PL Cmd 0b1011: Data Load	0b1010 - Ignored for frames received (all frames received are treated as commands).	0b0110	Used to distinguish type of packet for data packets and command packets.

Item Location ³	Valid Values	AMS-02 Usage for frames received	AMS-02 Usage for frames transmitted	Comment
Spare 7.15.1		Ignore	0	Not used. Note: Since AMS has no requirement for HOSC processing of science data telemetry, Per SSP57002C, all of word 7 is available to the payload use.
ElementID 7.14.4	0b0000: NASA 0b0001: NASA 0b0100: RSA 0b0101: CSA 0b0010: ESA/APM 0b0110: ESAATV 0b0011: NASDA 0b0111: ASI 0b1000: ESA/ERA 0b1001: NASA ISPR 0b1010: SPP 0b1011: HTV 0b1100-0b1111: Spare	0b0001 – Commands (Ignored).	0	Packet ID is Element-dependent, as defined by these 4 bits. The remaining 27 bits will be parsed into additional fields to support command-processing functions. It identifies the agency responsible for packet definition.
PacketID1 7.10.11	Per SSP41175-02 Table 3.3.2.1.1-4	Ignored.	0x1111	This value depends on the ElementID field.
PacketID2 8.15.16	Per SSP41175-02 Table 3.3.2.1.1-4	Ignored.	0x2222 Note: Per SSP57002C this is Data Cycle Counter.	This value depends on the ElementID field.

Figure 4 CCSDS Secondary Header

3.3.3 AMS Frame Headers And Frame Checksums

Item Location ⁴	Valid Values	AMS-02 Usage for frames received	AMS-02 Usage for frames transmitted	Comment
FBI 9.15.2	0	N/A	0	Reserved for future brilliant invention. <u>This word appears only as noted below.</u>
AMSequence ⁵ 9.15.4	0 – 16383	In streams where it appears it is used to reconstitute the CCSDS SequenceNo field.	For streams where it appears frames are generated with this as a copy of SequenceNo	Equivalent to the CCSDS sequence number

⁴ This area contains the word.start-bit.number-bits

⁵ This word appears only in H&S data via PLMDM and ground commands. For these paths the CCSDS header is not in our control.

Item Location ⁴	Valid Values	AMS-02 Usage for frames received	AMS-02 Usage for frames transmitted	Comment
FrameStatus 10.11.12	Bit Mask. 0b1xxx: Randomize 0bx1xx: CRC 0bxx1x: EXTCMD 0bxxx1: AMSSHf	Logical OR of valid values as appropriate	Logical OR of valid values as appropriate	<u>Randomize</u> – This frame has been pseudo-randomized for STS KU transmission. See Section 7.2.2 <u>CRC</u> – This frame has a CRC placed at the end, similar to NASA check word. <u>EXTCMD</u> – A command frame from an organization external to the AMS-POCC (MSFC, JSC, Timeliner, ISS Crew, ...) <u>AMSSHf</u> – AMS Secondary Header Flag. If present the frame has a 10 byte AMS Secondary Header (CHD).
Link1StBlock 10.11.12	0xFFF: Fill frame 0xFFE: No block starts 0–0xFFD: Pointer	As appropriate.	As appropriate	16-bit word offset to the first AMS Block in the frame. It is possible that no block starts in the frame in which case this pointer is 0xFFE. If the frame is a fill frame to be ignored the value is 0xFFF. The pointer is relative to the first 16-bit word after Link1StBlock. The value 0x0 means the first 16-bit word after the headers is the AMSBlock ByteCount.
AMS 2ndary header 11.15.80	See section 18, Critical Health Data Format			The AMS-02 2 nd ary header is the Critical Health Data.

Item Location ⁴	Valid Values	AMS-02 Usage for frames received	AMS-02 Usage for frames transmitted	Comment
AMS Block(s)		Segmented variable length data blocks, decommutatable by AMS only.	Segmented variable length data blocks, decommutatable by AMS only	Segmented variable length data blocks, decommutatable by AMS only
AMSCheckWord	0 - 65535			AMS CRC value if FrameStatus has CRC bit set. This is the last two bytes of AMS data within a CCSDS packet. Note: AMSCheckWord and CheckWord are not mutually exclusive.
CheckWord	0 - 65535	All commands have CheckWords computed and verified. Commands with invalid CheckWords are ignored.	For payload-to-payload commands this value is required.	<p>“16-bit add without carry” check word. When present, the CheckWord is the last 16-bit word of the CCSDS packet.</p> <p>The CheckWord is a 16-bit add without overflow carry over the entire packet (except the CheckWord position). (SSP 50184 (draft) 1-Aug-2000).</p>

Figure 5 AMS Frame Headers And Frame Checksums

3.4 APID Utilization

AMS-02 Data is logically organized as streams of data. Which data stream a particular AMSFrame belongs to is recognized by the APID of its CCSDS header⁶. (See Sections 1.3 and 8 for more details). The following table lists all the APID values used to define streams in the AMS-02 system.

Symbolic APID	Stream Represented	Interface	Assigned Value	Stream Handle
AMSCMD	Ground commands to AMS-02	OIU & LRDL (1553)	See below	0
AMSHK ⁷	AMS-02 housekeeping data plus AMSCMD replies	OIU & LRDL (1553)	0x36C (876)	1
AMSSCI	AMS-02 science data	HRDL STS-RS422	0x3D0 (976)	2
AMSHKH	AMS-02 housekeeping data plus AMSCMD replies	HRDL STS-RS422	0x3D1 (977)	3
PBCKSCI	Playback of recorded AMSSCI	HRDL	0x3D2 (978)	4
PBCKHKH	Playback of recorded AMSHKH	HRDL	0x3D3 (979)	5
PTOPCMD ⁸	Payload to payload command	HRDL	0x3D4 (980)	6
PTOPREPLY ⁹	Payload to payload replies	HRDL	0x3D5 (981)	7
ACOPCMD	Ground commands to ACOP	RIC-LAN	See below	8
ACOPHK	ACOP housekeeping data plus ACOPCMD replies	RIC-LAN	0x36C (876)	9
ACOPQC	ACOP QC sampling of AMSSCI	MRDL	0x3CF (975)	10
SPARE1	Spare		0x3D7 (983)	N/A
AMSFILL	NASA defined fill frame APID – 0x7FF	STS-RS422	0x7FF	N/A

⁶ The exceptions to this are the AMSHK and ACOPHK streams. The ISS systems strip the CCSDS header from this data. These streams are identified during ground processing by their source.

⁷ PIRN 52050-NA-0032 discusses that APID 0 is available for use by Payloads in health & status and file transfer packets. Its use is not mandatory

⁸ While this is a private payload-to-payload stream one side of each direction of the conversation on this APID will appear in downlink data due to the nature of the APS tee function.

⁹ See note above

Figure 6 APID Symbolic Values

ISS Command APIDs (used on S-band) are controlled and defined by the Core ICD and are documented in SSP 50539. APIDs are defined specific to a particular pair of physical locations. The follow defines the APIDs possible for AMS-02 and ACOP:

19 - MCC-H to ACOP in ER4 (LAB1P2)
119 - POIC to ACOP in ER4 (LAB1P2)
219 - PCS/P1 to ACOP in ER4 (LAB1P2)
319 - PCS/P2 to ACOP in ER4 (LAB1P2)
419 - PCS/P3 to ACOP in ER4 (LAB1P2)
519 - PCS/P4 to ACOP in ER4 (LAB1P2)
619 - PCS/P5 to ACOP in ER4 (LAB1P2)

21 - MCC-H to ACOP in ER3 (LAB1P4)
119 - POIC to ACOP in ER3 (LAB1P4)
219 - PCS/P1 to ACOP in ER3 (LAB1P4)
319 - PCS/P2 to ACOP in ER3 (LAB1P4)
419 - PCS/P3 to ACOP in ER3 (LAB1P4)
519 - PCS/P4 to ACOP in ER3 (LAB1P4)
619 - PCS/P5 to ACOP in ER3 (LAB1P4)

24 - MCC-H to AMS at S3-2
124 - POIC to AMS at S3-2
224 - PCS/P1 to AMS at S3-2
324 - PCS/P2 to AMS at S3-2
424 - PCS/P3 to AMS at S3-2
524 - PCS/P4 to AMS at S3-2
624 - PCS/P5 to AMS at S3-2

During STS operations the APID for AMS-02 commands will be **TBD**.

The ISS program has assigned the following values to AMS-02:

APIDs: 974-983

SSIDs: 308-309

SSIDs are SubSet IDs. These are used to identify the health and status packets of payloads much as APIDs are used to identify telemetry packets.

4 Word Size, Alignment, and Ordering

4.1 Word and Byte Ordering

4.1.1 For Telemetry From AMS-02 And ACOP

The following rules apply to the word and byte order of the data.

1. For parameters which are larger than one byte (8-bits) the most significant byte (MSB) shall be transmitted first, followed by the next most significant byte and so forth until the least significant byte (LSB) is the last byte transmitted.
2. The transmission order of the bytes (contiguous 8 bit groups) and bits within each word shall be most significant followed by least significant.

This ordering is commonly called Big Endian (or Motorola formatting).

4.1.2 For Ground Commands To AMS-02 And ACOP

For commands sent from the ground segments to AMS-02, the data ordering shall be the same as section 4.1.1 (Big Endian).

4.1.3 For Payload to Payload (AMS-02, ACOP, DDRS2) Commands

For commands sent among the AMS-02 payloads, the data ordering shall be the same as section 4.1.1 (Big Endian).

4.1.4 For Commands From PLMDM and PCS to AMS-02 and ACOP

For commands from PLMDM and PCS to AMS-02 and ACOP the data ordering shall be the same as section 4.1.1 (Big Endian).

5 Introduction To 1553¹⁰

This section introduces 1553 in general. The STS and ISS system support a subset of this functionality.

MIL-STD-1553 is a military standard that defines the electrical, mechanical and timing specifications for a dual-redundant communication network that interconnects cooperating digital units in a system. This communication network is also referred to as a data bus. MIL-STD-1553 is a 1Mbit/sec bus. It is a highly reliable bus, both because of its extremely low error rate (one word fault per 10 million words), and because of its dual-redundant architecture.

5.1 General

MIL-STD-1553 is a data bus that interconnects up to 31 terminals (referred to as Remote Terminals, or RT's), controlled by a single controller unit (referred to as the Bus Controller, or BC). All of the RT's, and the BC, are connected using two separate busses. These are named the Primary Bus (or bus 'A') and the Secondary Bus (bus 'B'). Messages are normally transferred only on the primary bus. If a message fails to be transferred over one bus, transfer may be retried on the other bus. This bus switching is solely at the discretion of the BC, a properly functioning RT must respond on which ever bus is active.

5.2 Bus Controller (BC)

The BC is the only entity that can initiate the transfer of a message over the bus. In a typical MIL-STD-1553 bus, the BC has a predefined sequence of messages that it repeats indefinitely.

5.3 Remote Terminal (RT)

An RT can send out up to 30 different messages (numbered 1 through 30), and receive up to 30 other messages (also numbered 1 through 30). The number of the message in an RT is referred to as a Sub Address. Each message can hold between 1 and 32 data words, 16 bits per word. An RT sends or receives data only when instructed to do so by the BC.

5.4 Message Types

There are four basic kinds of messages that the BC can cause to be transferred over the bus. These include RT to RT, RT to BC, BC to RT and Mode Commands.

- In an RT-to-RT message, the BC instructs one RT to be prepared to receive a certain number of words into one of its sub addresses, and then instructs another RT to send that number of data words from one of its sub addresses. Both RT's are ignorant of each other. All they concern themselves with are commands from the BC.

¹⁰ Paraphrased from various web pages

- In an RT to BC message, the BC instructs an RT to transmit a certain number of data words from one of its sub addresses, and then reads the data words that the RT transmits.
- In a BC to RT message, the BC instructs an RT to be prepared to receive a certain number of data words into one of its sub addresses, and then transmits that number of data words to the RT.
- Mode Command messages are used for management of the bus. They include a variety of messages, including, for example, requests from an RT to shut down its transmitter, or to send the results of the last built-in-test that it performed. Mode command messages are short, and contain one or no data words.

5.5 Message Transfers

To understand how message transfer is accomplished, we must discuss the types of data words that MIL-STD-1553 uses. Words in MIL-STD-1553 always contain 16 bits of data. Each word is followed by a parity bit, and preceded by a special sync pattern, 3 bits in length. This sync pattern distinguishes between data words (words that carry pure data), and command and status words (non-data words). The BC sends Command Words to RT's to instruct them to receive or transmit data, or to perform some operation. RT's send out Status Words to notify the BC of any problems they experience while carrying out a BC's command, and of their general status.

To cause an RT to send data out, or to receive data, the BC must send out a command word that specifies the number of the RT and the sub-address within that RT. The command word specifies whether the RT should transmit or receive data words, and also indicates the number of these data words.

Whenever an RT is commanded to transmit data, it immediately responds with a status word that indicates to the BC that its command was accepted. The BC waits for this status word, up to a certain limit, after which it flags an RT Response Time error. After sending out the status word, the RT proceeds with transmission of the requested number of data words. The BC waits for the RT to send out the agreed number of words, after which the transmitting RT's job is done. If the RT sends out too few or too many data words, the BC flags an error.

Whenever an RT is commanded to receive data, it waits for the specified number of data words to appear on the bus (regardless of which entity transmits them). Once the specified number of data words is received, the RT responds with a status word that the BC waits for. In this status word, the RT indicates the success of the transfer, as far as it is concerned. If too few or too many words were received, the status word flags an error. Upon reception of the status word, the BC in turn examines the status word, and flags an error if one is flagged in that word. If the status word fails to arrive from the RT, the BC flags an RT Response Time error.

5.6 Mode Commands

Mode commands are special messages that are distinguished from normal messages (RT to RT, RT to BC and BC to RT) by making use of sub-addresses 0 or 31. These two sub-addresses are reserved for mode commands

5.7 Broadcast Messages

RT number 31 is reserved for broadcast messages. When the BC sends out a command word with this RT number, all RT's become prepared to receive the data words that follow. None of them responds with a status word once all data words are received, in order not to cause any collision.

6 Introduction to HRDL on ISS

The High Rate Data Link (HRDL) on ISS is a simplex link composed of a transmit station and receive station linked with optical fiber to the Automated Payload Switch (APS). Each payload site has both a transmit link and a receive link. The logical organization of HRDL is shown in Figure 7 High Rate Data Link Design.

The APS converts the optical signal to a copper based signal, provides an electrical cross bar switching and then optical signal regeneration to either one (point to point) or two (tee connection) HRDL devices on ISS. Cross bar connections within the APS are controlled by ground commanding as needed to manage telemetry and interconnections for ISS. Cross bar connections are independent for the transmit and receive links. The number of total connections supported within the APS is a limited resource requiring ISS program management as a shared resource.

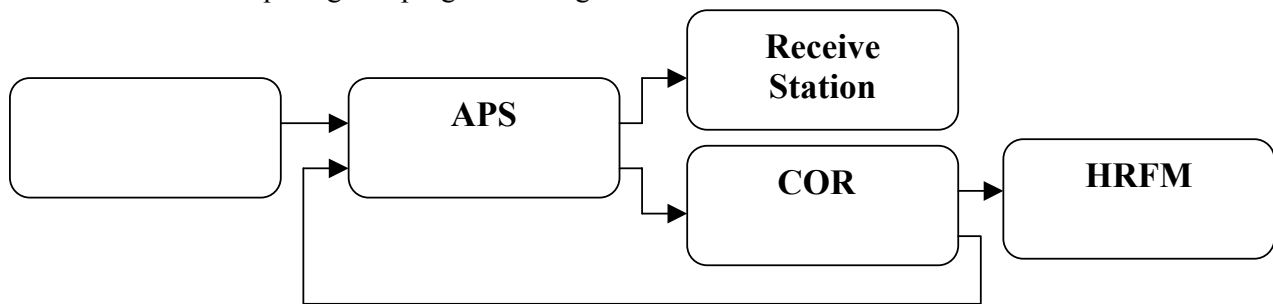

Figure 7 High Rate Data Link Design

Payloads have two targets for HRDL transfers. The first is the High Rate Frame Multiplexer (HRFM), which interleaves data to the KU-Band transmission system for downlink. The second target is another payload.

There is a some-what opaque box between payloads and the HRFM called the Communications Outage Recorder. The purpose of this box is to provide a recording of telemetry during periods where there is no KU-Band coverage. Due to the design of the overall ISS telemetry system, and the data volumes of AMS-02, this device is not foreseen as particularly helpful for AMS-02.

Information about HRDL is primarily derived from SSP 50184 Rev B dated 18 October 2000.

6.1 HRDL Protocol and Framing

The HRFM Ku-Band system supports two rigidly defined downlink protocols: the Consultative Committee for Space Data Systems (CCSDS) Packet protocol and bitstream protocol. AMS-02 operates only with the CCSDS Packet protocol.

The physical signaling for HRDL is performed using TAXI protocol at 125Mbaud and is independent of the data rate. When data is not available for transfer on the HRDL link TAXI SYNC symbols are transmitted. The actual data rate is determined by the rate of valid non sync symbols being transmitted. AMS-02 firmware uses three parameter registers to control the data rate of transmissions on the HRDL interfaces: the number of syncs between CCSDS packets, the number of data symbols in a row,

and the number of syncs between a row data symbols (the last two form a “data to sync” ratio).

6.2 Known Problems with HRDL

The APS and HRFM systems have documented problems that directly affect the HRDL operations. This section documents known issues with the use of the HRDL system and documents how AMS-02 (and ACOP) handles the issues.

6.2.1 Incorrect HRFM MPDU First Header Pointer

Documented in SSP 50184B Section 3.3.3.1.1.1 CCSDS Packet Data Frame Sizes.

Resolution: All packets transmitted via HRDL to and from AMS-02 and ACOP are a multiple of four bytes. This prevents this problem from occurring.

6.2.2 Maximum Contiguous Data Transfer

Documented in SSP 50184B Section 3.3.3.1.2.2.1 Maximum Contiguous Data Transfer.

Resolution: Both JIM_HRDL and ACOP6T boards provide a configuration register specifying the current data to sync ratio used to meter data rates. This register must always have a data symbol count less than 25 and a non-zero sync symbol count.

6.2.3 Distribution Of Sync Symbols

Documented in SSP 50184B Section 3.3.1.2.2 Distribution of Sync Symbols.

Resolution: The “parsing of sync symbols” is governed by section 6.2.2.

6.2.4 Fail to Lock-On State by APS

Documented in SSP 50184B Section 3.3.1.1.2 Lock-On State.

Note: This issue was discussed with Alan Joseph (Boeing-HB 714-896-2647) early Jul-03. Alan confirmed that his characterization of the problem was a failure to establish lock on state when sync symbols are sent after light has been off. No testing was done to see if once locked on the APS failed to maintain sync but it is believed that sync is never lost.

Resolution: AMS-02 has the ability to inject “random data” as suggested by SSP50184B.

Notes from Gary Knickerbocker: Concerning the question about how often the APS Sync Anomaly shows up, only during initial routing of a link is it possible that this will occur. Appears to be random. We see it almost every time we route the C&C MDM output through Ku-band but we rarely see it when we route the Payload MDM. We do know that data flow seems to help the APS establish sync. The C&C MDM doesn't provide constant data flow (i.e. data symbols, it always provides sync symbols), it only sends data when a ZOE Dump is commanded, whereas the Payload MDM is always producing data. Most of the time on the C&C MDM, we have to get the CATO to start a ZOE dump to establish sync through the APS.

6.3 Telemetry Data Rate Management

The ISS program requires that a payload have the ability to control its HRFM telemetry rate from 0Mbits/second to not to exceed 100Mbits/second in increments of 0.43195 Mbits/second.

At the link level HRDL is always clocked at a 100 Mbits/sec data rate. Payloads must be able to limit their data transmission rate to the HRFM by controlling the insertion of syncs between packets and within packets. Details regarding data rate control are found in SSP 50184B section 3.3.1 HRDL Protocol Common Rules.

This is implemented in AMS-02 by providing commanding to set the desired communication rate.

6.4 Physical Media

HRDL signals are carried on fiber optic cables. These multimode fibers are unique to ISS and have a core diameter of 100 micron and cladding diameter of 140 micron. The attenuation is 1290nm. ISS cable has a MIL-STD-104 violet jacket.

7 STS Command and Telemetry Implementation

This section discusses what telemetry is present, and which interface that it is present on, when AMS-02 is operational for checkout during transportation on STS to ISS.

7.1 STS OIU 1553 Interface Utilization

A 1553 bus connection to AMS-02 while in the Orbiter cargo bay shall be utilized to provide commands to and telemetry from the AMS-02. In operation of this interface, the Orbiter Interface Unit (OIU) performs as the 1553 Bus Controller (BC) and the AMS functions as a 1553 Remote Terminal (RT).

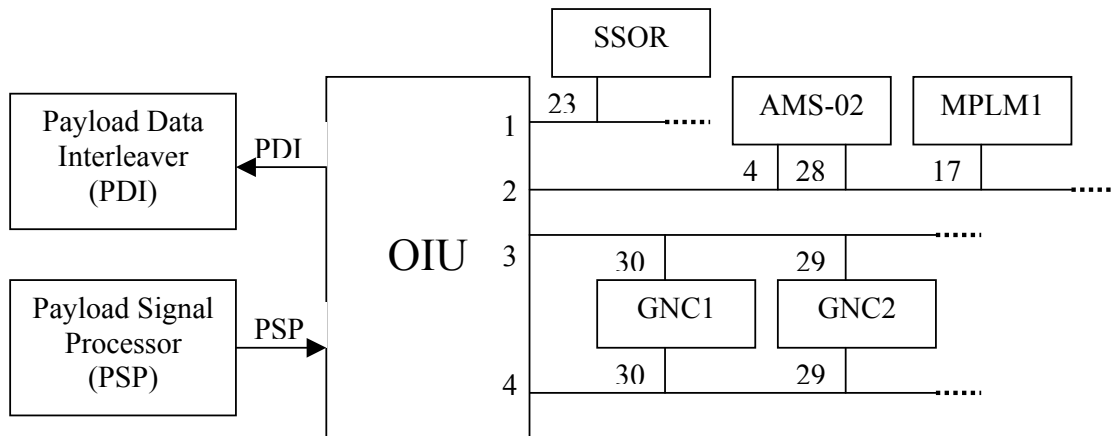

Figure 8 OIU Bus Topology

This link carries the AMSHK data stream to be down linked, and AMSCMD, which is being up linked. Critical Health Data is present in the AMSHK stream.

7.1.1 1553 House Keeping (Down Link)

The AMSHK data stream is created by AMS-02 and down linked via this path. While not required by NASA, AMS-02 utilizes CCSDS headers for this link simplifying the development of ground processing systems. The Critical Health Data is present on STS and its location may be defined in Annex 4.

The following describes the mechanics of transferring data over this link:

During OIU operation AMS-02 generates a CCSDS packet of health and status data on a 1 Hz basis. The size of this packet is 1280 bytes.

The OIU broadcasts a "Synchronize With Data Word" Mode Command (Mode Code 10001) as the first message in sub-frame zero of each processing frame at a 10 Hz +/- 10 microseconds rate on a 100 ms boundary. This synchronizes the start of transfer of the generated 1 Hz CCSDS packet.¹¹

¹¹ When the OIU is commanded (see 7.1.3) to a new format AMS-02 must re-acquire frame sync with the OIU in the new format.

The OIU polls each of the two predefined “health and status” 1553 sub-addresses (see Section 7.1.9 OIU Sub-Address Assignments) during each 10 Hz processing frame to obtain the data for the CCSDS packet.

The pair of 1553 replies generated by AMS-02 in this ten-hertz cycle is assembled by the OIU into a format suitable for transfer to the Payload Data Interleaver (PDI). Each PDI frame contains 1/10 of an AMS-02 CCSDS packet.

The data down linked is delivered to JSC-CIP. (See paragraph 11.2.1).

During ground processing the PDI frame’s attached sync marker frame count (which is the same as the broadcast sync parameter used during 1553 polling) is used to determine the start of a CCSDS packet (sync marker frame count modulo ten is zero). Ten PDI frames are re-assembled into a 1 Hz CCSDS packet for handling by the ground systems.

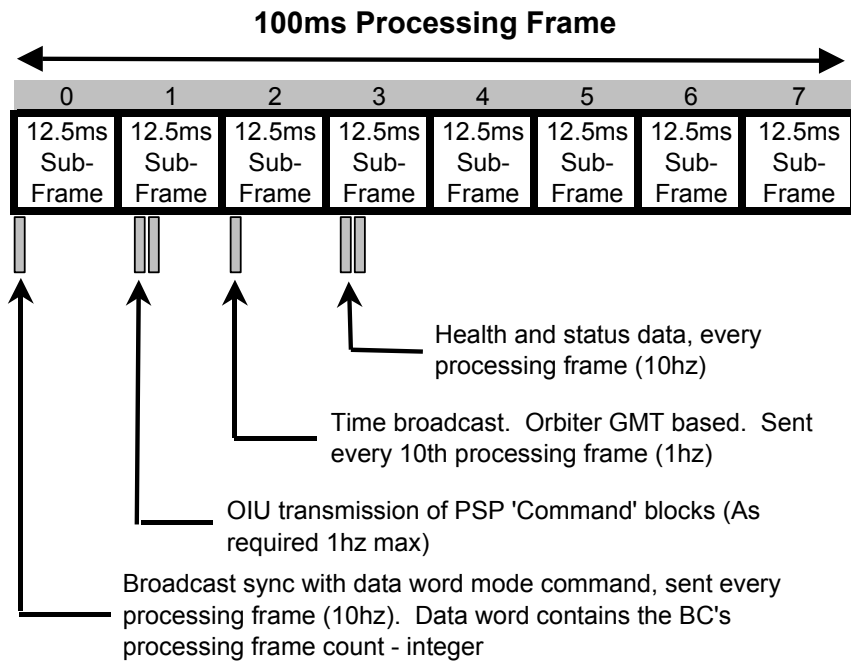
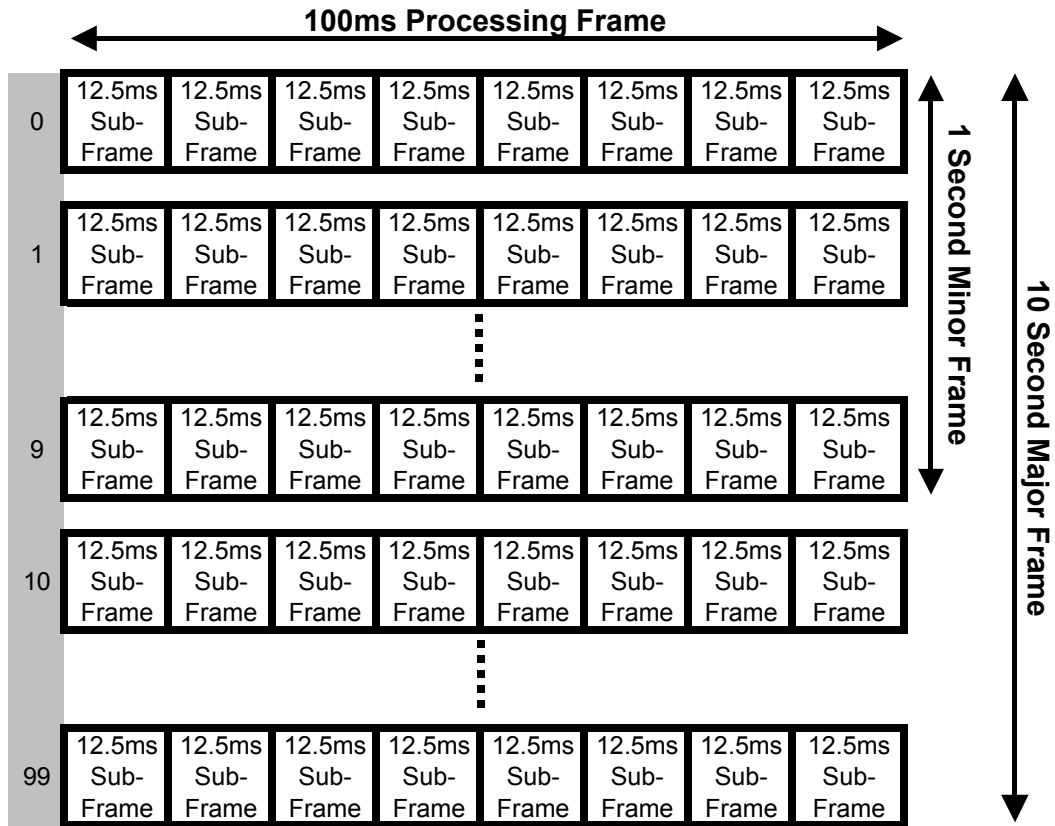

Figure 9 OIU Frame Concept

7.1.2 OIU/PDI 1553 Data Layout Implementation Details

The implementation details for the data layout of the first 1553 block of a 1hz CCSDS packet follows in Figure 10 OIU/PDI HK 1st 1553 Sub Address Block. The remaining nineteen 1553 blocks contain AMSBlock data.

	15	14	13	12	11	10	9	8	7	6	5	4	3	2	1	0	
1	VersionID			Type	SHF	APID											CCSDS Primary
2	Seq Flag		SequenceNo														
3	PacketLen																
4	TimeMSB																CCSDS Secondary
5	TimeLSB																
6	FineTime						TimeID	CHK	ZOE	PacketType							
7	Spare	ElementID				PacketID1											AMS Sec
8	PacketID2																
9	FrameStatus				Link1StBlock												AMSBlock(s)
10	CHD																
15																	
//																	
32																	
	15	14	13	12	11	10	9	8	7	6	5	4	3	2	1	0	

Figure 10 OIU/PDI HK 1st 1553 Sub Address Block

All values, unless discussed below, are as per section 3.2.

Item	Valid Values	AMS-02 Usage	Comment
PacketLen	TBD	Fixed	FrameLen is fixed at 1280 – 7 bytes
FrameStatus			Critical Health Data must be present on STS.

Figure 11 OIU/PDI Implementation Notes

7.1.3 OIU PDI Frame Formats

The OIU produces PDI frames of data in several formats. For each of these formats the AMS-02 HK data is located at a different offset within the PDI frame. Three such formats are defined for the AMS-02 operation. Other formats may exist for which no AMS-02 data is present.

Format 5¹² – AMS-02 is operating independently. In this format the AMS-02 HK data appears as the first and only telemetry of the PDI frame.

Format 11¹³ – AMS-02 is operating in conjunction with the Space to Space Orbiter Radio (SSOR) during docking operations with ISS. In this format SSOR telemetry data precedes the AMS-02 HK data in the PDI frame.

Format 12¹⁴ – AMS-02 is operating in conjunction with the ISS during docked operations at ISS. In this format ISS CCS telemetry data precedes the AMS-02 HK data within the PDI frames (Note: 12 not available for FIT due to window size in SDT).

Formats 11 and 12 are known as super formats since they insert the telemetry of more than one payload into the PDI stream.

When the OIU is commanded to a new format AMS-02 must re-acquire frame sync with the OIU in the new format.

Format	Offset in Bytes
5	13 th byte if 1 st = = 1
11	99 th byte
12	211 th byte

Figure 12 Start of AMS-02 Data within PDI Frames

¹² FIT Temp assignment

¹³ FIT Temp assignment

¹⁴ FIT Temp assignment

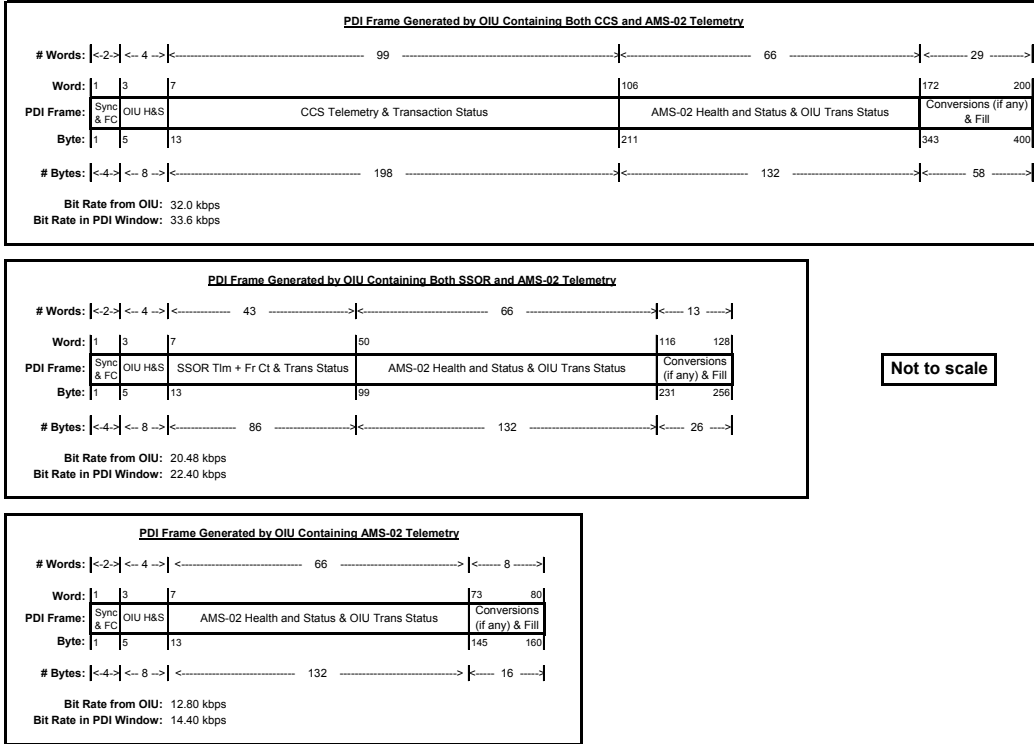

Figure 13 PDI Frame Layouts

Item	Number of bits per PDI minor frame (100 ms.)	Function
Sync & FC	32	Four (4) – 8 bit sync and counter words. Sync - C9 5A 63 Counter - is the processing frame counter (0-99).
OIU H&S	64	Eight (8) – 8 bit OIU health and status words. See layout in Section 6.3 of the OIU User's Guide (JSC27669) or table below.
AMS-02 H&S	1024	128 bytes of AMS-02 data followed by OIU transaction status words as defined in the OIU User's Guide (JSC27669) section 6.5.1

Figure 14 PDI Data Field Details

Standard Set of OIU Health and Status Parameters -- 8/6/96 4:14 PM

Status Item	min bits	bits used	# rcn IDs	# MSIDs	Parent MSIDs
BC/RT Indicator	8	8	1	8	1
Channel A/B	8	8	1	8	1
Dev1 (Phys) Code/Sync Status	6/2	6/2	1	2	1
Dev1 Bus/RT Number	3/5	3/5	1	2	1
Dev1 Data Start Byte/OIU RT#, Bus1	10/5	10/6	1	3 *	2 *
Dev2 (Phys) Code/Sync Status	6/2	6/2	1	2	1
Dev2 Bus/RT Number	3/5	3/5	1	2	1
Dev2 Data Start Byte/OIU RT#, Bus2	10/5	10/6	1	3 *	2 *
Dev3 (Phys) Code/Sync Status	6/2	6/2	1	2	1
Dev3 Bus/RT Number	3/5	3/5	1	2	1
Dev3 Data Start Byte/OIU RT#, Bus3	10/5	10/6	1	3 *	2 *
Dev4 (Phys) Code/Sync Status	6/2	6/2	1	2	1
Dev4 Bus/RT Number	3/5	3/5	1	2	1
Dev4 Data Start Byte/OIU RT#, Bus4	10/5	10/6	1	3 *	2 *
PDI (Station) Mode	8	8	1	1	0
OIU Physical Box ID	5	8	1	1	0
OCC Error Log Latest Entry #	7	8	1	1	0
			1		
			1		
Frame Count Validity Bit	1	1	1	1	1
			20	48	19

Status Item	min bits	bits used	# IDs	# MSIDs	Parent MSIDs
Command Msg Counter	16	16	1	3 *	0
OCC Error Log Wrap Counter	16	16	1	3 *	0
PSP/PTB Error Log Wrap Cntr	16	16	1	3 *	0
PDI Error Log Wrap Counter	16	16	1	3 *	0
OIU-Gen Broadcast Time	48	48	1	1	0
OIU-Gen Broadcast Time	20	24	1	1	0
Station-Gen Broadcast Time	48	48	1	1	0
Station-Gen Broadcast Time	20	24	1	1	0
Single Bit Status Byte 1	8	8	1	8	1
Single Bit Status Byte 2	8	8	1	8	1
Single Bit Status Byte 3	8	8	1	8	1
Single Bit Status Byte 4	8	8	1	8	1
Single Bit Status Byte 5	8	8	1	8	1
Single Bit Status Byte 6	8	8	1	8	1
Single Bit Status Byte 7	8	8	1	8	1
Single Bit Status Byte 8	8	8	1	8	1
Single Bit Status Byte 9	8	8	1	8	1
Single Bit Status Byte 10	8	8	1	8	1
			18	96	10

To seconds, year minus 1900
Microseconds portion of time
To seconds, year minus 1900
Microseconds portion of time

Standard H&S Set	
Total IDs:	38
Total MSIDs:	173

* Assigned MSIDs to 16-bit component and to certain 8-bit subcomponents in anticipation of possible GPC display.

PDI Frame Bytes 1-3 are sync, and Byte 4 is minor frame count (0-99).

bit:	PDI Frame Byte 5							PDI Frame Byte 6							PDI Frame Byte 7							PDI Frame Byte 8							PDI Frame Byte 9							PDI Frame Byte 10												
fr	0	1	2	3	4	5	6	7	8	9	10	11	12	13	14	15	16	17	18	19	20	21	22	23	24	25	26	27	28	29	30	31	32	33	34	35	36	37	38	39	40	41	42	43	44	45	46	47
0	PDI (Station) Mode							OIU Physical Box ID							BC/RT Indicator							Spare							Channel A/B							OCC Err Log Latest Entry #												
1	Station-Gen Broadcast Time (To Seconds, Year Minus 1900)																																															
2	OIU-Gen Broadcast Time (To Seconds, Year Minus 1900)																																															
3	Station-Gen Broadcast Time, Microseconds Portion of Time																					OIU-Gen Broadcast Time, Microseconds Portion of Time																										
4	Single Bit Status Byte 1							Single Bit Status Byte 2							Single Bit Status Byte 3							Single Bit Status Byte 4							Single Bit Status Byte 5							Single Bit Status Byte 6												
5	Single Bit Status Byte 7							Single Bit Status Byte 8							Single Bit Status Byte 9							Single Bit Status Byte 10							Command Msg Counter																			
6	Dev1 (Phys) Code/Sync Stat							Dev1 Bus/RT Number							Dev1 Data Start Byte / OIU RT #, Bus 1							OCC Error Log Wrap Counter																										
7	Dev2 (Phys) Code/Sync Stat							Dev2 Bus/RT Number							Dev2 Data Start Byte / OIU RT #, Bus 2							PSP/PTB Error Log Wrap Counter																										
8	Dev3 (Phys) Code/Sync Stat							Dev3 Bus/RT Number							Dev3 Data Start Byte / OIU RT #, Bus 3							PDI Error Log Wrap Counter																										
9	Dev4 (Phys) Code/Sync Stat							Dev4 Bus/RT Number							Dev4 Data Start Byte / OIU RT #, Bus 4							Spare																										

bit:	PDI Frame Byte 11							PDI Frame Byte 12								
fr	48	49	50	51	52	53	54	55	56	57	58	59	60	61	62	63
0	fcv	Spare														
1	fcv	Spare														
2	fcv	Spare														
3	fcv	Spare														
4	fcv	Spare														
5	fcv	Spare														
6	fcv	Spare														
7	fcv	Spare														
8	fcv	Spare														
9	fcv	Spare														

Sync Status	Meaning
0	Device not in PDI Mode (format)
1	In sync
2	Out of sync
3	N/A (not a frame-bearing RT)

Frames 0-9 repeat to frames 90-99.

Figure 15 OIU Health and Status

7.1.4 1553 Commanding (Up Link)

This link carries the AMSCMD Data Stream.

Command data consists of AMS Frames (with CCSDS headers and containing AMS Blocks). Command data is framed using a frame size of 124 bytes (inclusive of headers and check words). The AMS-02 Secondary Header is not used.

The command data originates from either JSC/MSFC ground equipment (predefined “fixed” commands) or from the AMS-02 POCC (any form of command). All commands are up linked to STS and delivered to the PSP.

The OIU receives the command frames from the PSP interface, strips the OIU envelop words, adds the command counters, and transfers it to AMS-02 via the 1553 interface.

The OIU limits the command rate to 1 Hz (ground systems may further limit this rate). AMS-02 ground segment equipment must enforce this limit during flight.

By definition STS OIU command data is two 1553 messages (or sub-addresses). The OIU always transmits both sub-addresses within one processing frame to two consecutive sub-addresses.

The AMS-02 POCC delivers commands to the CIP at JSC.

7.1.5 1553 Command Data Layout Implementation Details

The following table shows the layout of the 1553 blocks received by AMS-02 for ground commands sent via the OIU.

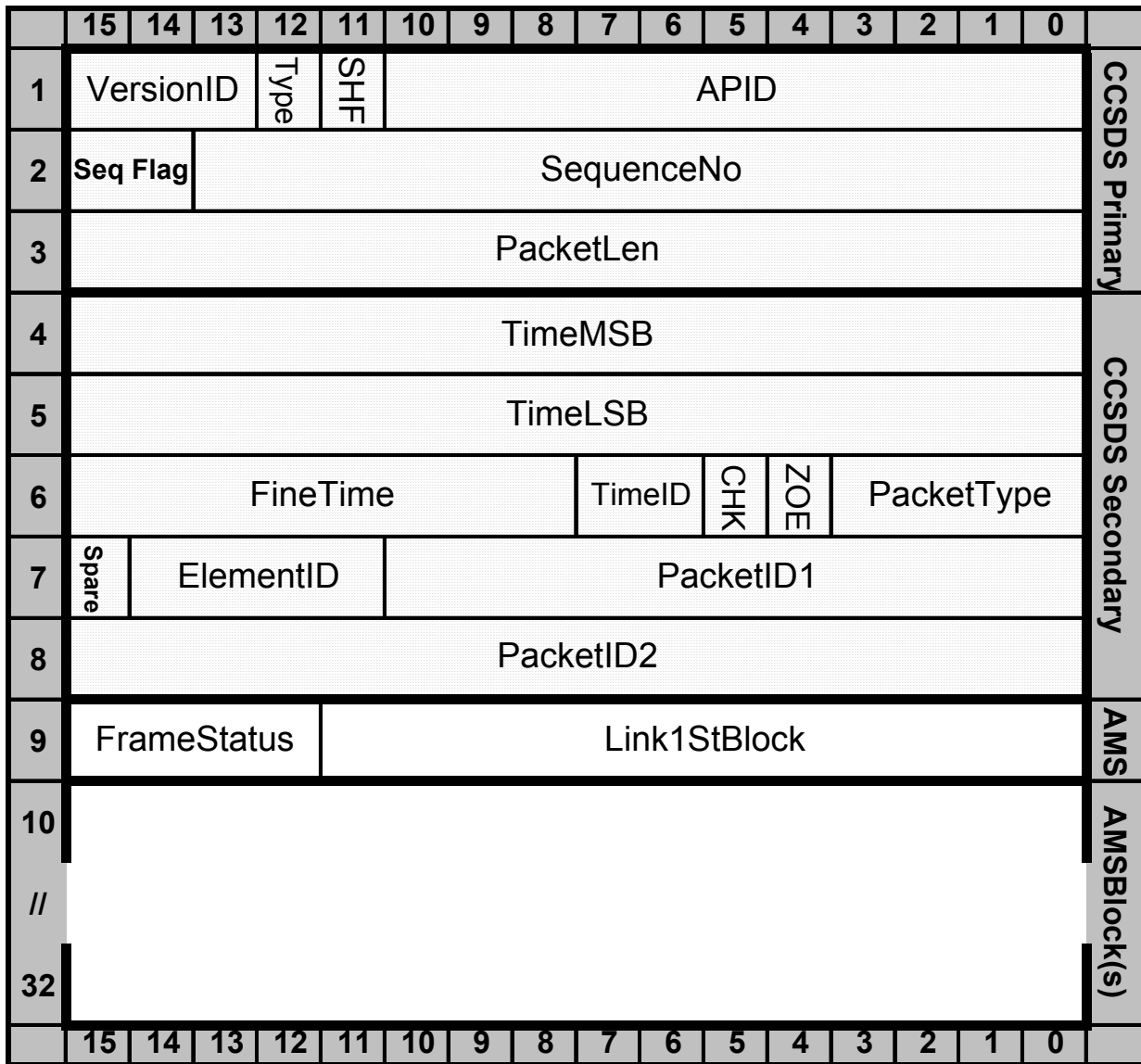

Figure 16 1st Sub Address Block For AMS Command Via OIU

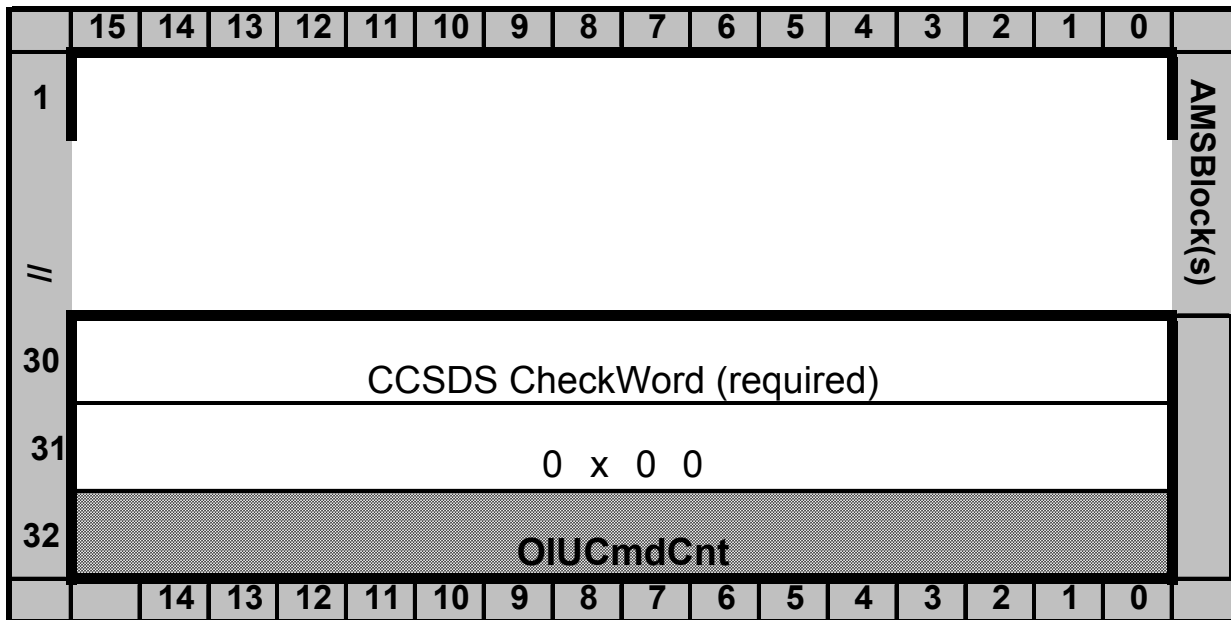

Figure 17 2nd Sub Address Block For AMS Command Via OIU

Item	Valid Values	AMS-02 Usage	Comment
PacketLen	117 (128-7-4)	117	See: section 3.3
CHK	1	1	CCSDS CheckWord is required.
CheckWord	0-65535	Checked. Commands with invalid CheckWords are ignored.	See: section 3.3
OIUCmdCnt	0-65535	TBD	System wide OIU command count. (Note: MPLM only considers commands when this value changes.)

Figure 18 Values in Commands Via OIU

Notes from Buddy:

The CCSDS CheckWord can never be in Word 31 of the 2nd block for commands sent through the OIU. Word 31 will always be zero because the OIU sets it to zero. Since the largest command that can be sent through the OIU is 62 words in length, the maximum word location for the CheckWord is Word 30 of the 2nd block. You might consider putting the CheckWord in the middle of the block and leaving the associated word number off. However, since the CheckWord is defined to be the final word of the CCSDS command packet, the CheckWord may even appear in the 1st block if the command is short enough. I'm not sure how you would want to depict that. Word 31 in Figure 17 should be shown to contain "Zero". (The OIU always inserts zeroes between the final word of the AMS command and the OIU Command Count.)

7.1.6 Command Replies

Command replies from the AMSCMD stream are directed to the stream AMSHK and carried on this 1553 link.

7.1.7 Time Distribution

The OIU broadcasts its time once per second in sub-address 29. The following table defines the format of this data:

<u>Word #</u>	<u>Bits</u>	<u>Description</u>	<u>Function/Units</u>	<u>Limits or Range</u>
CW		1553 Command Word		N/A
1	0-7	CCSDS preamble	Preamble field "01010000"	N/A
1	8-15	Time Code – year high	Most significant 8 bits of BCD year field	19 to 20
2	0-7	Time Code – year low	Least significant 8 bits of BCD year field	0 to 99
2	8-15	Time code - month	BCD month field	1 to 12
3	0-7	Time code – day of month	BCD day of month field	1 to 31
3	8-15	Time code - hour	BCD hour field	0 to 23
4	0-7	Time code - minute	BCD minute field	0 to 59
4	8-15	Time code - seconds	BCD second field	0 to 59
5	0-11	Spare (unused bits)	N/A	0
5	12-15	Binary sub seconds high	Most significant 4 bits	0 to 15
6	0-15	Binary sub seconds low	Least significant 16 (1 bit=1 microsecond)	0 to 65535
7	0-15	UTC conversion parameters	UTC leap seconds (BCD)	0 to 9999
8	0-15	Not Used		0

Figure 19 OIU Broadcast Time Format

7.1.8 Mode Commands

The following table indicates the disposition of all mode codes supported.

T/R BIT	MODE CODE	FUNCTION	ASSOCIATED DATA WORD	BROADCAST ALLOWED	IMPLEMENTED By OIU	IMPLEMENTED By AMS	AMS Action
1	00000	Dynamic Bus Control	No	No	No	No	N/A
1	00001	Synchronize W/O Data Word	No	Yes	No	No	N/A
1	00010	Transmit Status Word	No	No	Yes	Yes	TBP

T/R BIT	MODE CODE	FUNCTION	ASSOCIATED DATA WORD	BROADCAST ALLOWED	IMPLEMENTED By OIU	IMPLEMENTED By AMS	AMS Action
1	00011	Initiate Self-Test	No	Yes	Yes	Yes	TBP
1	00100	Transmitter Shutdown	No	Yes	Yes	Yes	TBP
1	00101	Override Transmitter Shutdown	No	Yes	Yes	Yes	TBP
1	00110	Inhibit Terminal Flag Bit	No	Yes	No	No	N/A
1	00111	Override Inhibit Terminal Flag Bit	NO	Yes	No	No	N/A
1	01000	Reset Remote Terminal	No	Yes	Yes	Yes	TBP
1	10000	Transmit Vector Word	Yes	No	No	No	N/A
0	10001	Synchronize With Data Word	Yes	Yes	Yes	Yes	TBP
1	10010	Transmit Last Command	Yes	No	No	Yes	TBP
1	10011	Transmit BIT Word	Yes	No	No	Yes	TBP
0	10100	Selected Transmitter Shutdown	Yes	Yes	No	No	N/A
0	10101	Override Selected Transmitter Shutdown	Yes	Yes	No	No	N/A

Figure 20 AMS Mode Code Implementation For OIU

7.1.9 AMS Sub-Address Assignments For OIU Interface

SA#	Transmit (T/R=1)	Receive (T/R=0)
0	Mode Code (SAM=00000) Command	Mode Code Command
1	Health & Status (1)	Not Assigned
2	Health & Status (2)	Not Assigned
3	Not Assigned	Not Assigned
4	Not Assigned	Not Assigned
5	Not Assigned	Not Assigned
6	Not Assigned	Not Assigned
7	Not Assigned	Not Assigned
8	Not Assigned	Not Assigned
9	Not Assigned	Not Assigned
10	Not Assigned	Not Assigned

SA#	Transmit (T/R=1)	Receive (T/R=0)
11	Not Assigned	Not Assigned
12	Not Assigned	Not Assigned
13	Not Assigned	Not Assigned
14	Not Assigned	Not Assigned
15	Not Assigned	Not Assigned
16	Not Assigned	Not Assigned
17	Not Assigned	Not Assigned
18	Not Assigned	Not Assigned
19	Not Assigned	Not Assigned
20	Not Assigned	Not Assigned
21	Not Assigned	Not Assigned
22	Not Assigned	Not Assigned
23	Not Assigned	Not Assigned
24	Not Assigned	Not Assigned
25	Not Assigned	Not Assigned
26	Not Assigned	Not Assigned
27	Not Assigned	Command (1)
28	Not Assigned	Command (2)
29	Not Assigned	Broadcast Time
30	Not Assigned	Not Assigned
31	Mode Code (SAM=11111) Command	Mode Code Command

Figure 21 1553 Sub-Address Assignments For OIU Interface

7.2 STS RS422 Link Utilization

AMS-02 provides two transmit and two receive links to the aft flight deck. These are not independent but rather are duplicate connections for a single serial connection. Nominally one connection is made to the KU band for downlink (TX only) and the other to DDRS2. (Pre-launch the DDRS2 link is connected to the T0 cable.)

The frame size utilized on this link is 4084 bytes, including the ASM, in both directions.

Carried from AMS-02 to the aft flight deck on this link are the following streams: AMSHKH, AMSSCI, PTOPREPLY, and PTOPCMD.

All streams transmitted on this link by AMS-02 are down linked if the KU system is active. DDRS2 monitors this link and processes the AMSHKH and PTOPCMD streams only.

DDRS2 can direct back PTOPCMD and PTOPREPLY on this link.

Data transmitted on the KU-Band by this connection will be obtained at the JSC CIP as discussed in paragraph 11.2.2.

7.2.1 Attached Sync Marker (ASM)

Each block transferred begins with an attached sync marker. This is a four-byte value. The first three bytes are the constants: 0xFA 0xF3 0x20. The final byte is a rolling sequence frame number, 0x00 to 0xFF.

7.2.2 Pseudo-Randomization

To meet KU Band modulation requirements the data stream must be “pseudo-randomized” to support clock recovery while using Pulse Code Modulation (PCM) for the transmission. There can be no more than 64 successive bits without a bit transition and at least 128 bit transitions must occur within any 512 bits of data. To assure continuous clock recovery the data stream shall be designed to ensure continuous transmission of data meeting these modulation requirements. Should no data be available for transmission fill frames must be generated.

By inspection the frame headers themselves meet the above requirements. To support efficient handling of the RS422 link by DDRS2 the frame headers are not processed by pseudo-randomization. If specified the pseudo-randomization begins at the first byte past the AMS Frame Header and continues to include the remaining bytes in the frame, including any AMS-02 check word present. Pseudo-Randomization is always used during the flight.

7.2.3 RS422 Data Layout Implementation Details

The following diagram illustrates the layout for RS422 data streams.

	15	14	13	12	11	10	9	8	7	6	5	4	3	2	1	0		
1	0xFA								0xF3								ASM	
2	0x20								RollingCounter									
3	VersionID				Type	SHF		APID										CCSDS Primary
4	Seq Flag		SequenceNo															
5	PacketLen																	
6	TimeMSB																CCSDS Secondary	
7	TimeLSB																	
8	FineTime								TimeID	CHK	ZOE	PacketType						
9	Spare	ElementID				PacketID1												
10	PacketID2																	
11	FrameStatus				Link1StBlock												AMS	
12																	AMS BIKs	
2042																		
	15	14	13	12	11	10	9	8	7	6	5	4	3	2	1	0		

Figure 22 RS422 Data Layout

Notes:

1. RollingCounter is simply incremented and rolls around from 255 to 0.
2. Pseudo-randomization is performed for all data transmit by AMS-02 to the KU/DDRS link. DDRS2 does not perform pseudo-randomization on data it transmits to AMS-02.

3. If performed, the pseudo-randomization is performed from word 12 to the end of the packet.
4. Frame sizes are fixed at 4080 bytes.

7.3 STS KU Link

Nominally all data transmitted by AMS-02 is sent to the KU system for down link via Orbiter Ku-band channel 2 or 3 (TBD) (bent pipe).

7.4 STS DDRS2 Link

This link is merely an electrical copy of the link discussed in Section 7.2.

7.4.1 DDRS2 Data Recording and Monitoring

Nominally the AMSHKH and AMSSCI streams are recorded by DDRS2. Additionally DDRS2 de-frames the AMSHKH and ACOPREPLY streams to provide crew-monitoring abilities.

7.4.2 DDRS2 Crew Commanding

Crew commanding of AMS-02 is only supported via the Digital Data Recorder System 2 (DDRS2) – a JSC/MMO/LMSO provided system based on a PGSC. This system directs commands to AMS-02 via its RS422 transmit link on stream PTOPCMD and expects command replies to PTOPREPLY. Nominally the frames sent to AMS-02 will not have the pseudo-randomization performed. They do have full frame headers as described above.

8 ISS AMS-02 Command and Telemetry Implementation

This section discusses what telemetry is present, and which interface that it is present on, when AMS-02 is operational on ISS. SSP57003 defers the definition of 1553 handling to SSP 52050. Section 3.2.3.5 of 52050 covers health and status collection by the PLMDM. Section 3.2.3.10 covers low rate telemetry (not used by AMS-02). Section 3.2.3.4 covers command requirements. Section 3.2.3.12 covers broadcast time. Section 3.2.3.8.1 covers broadcast ancillary data requirements.

8.1 ISS AMS-02 LRDL (1553) Utilization

A 1553 bus connection in the UMA connects AMS-02 to a PLMDM (Payload Multiplexer/De-multiplexer). In operation of this interface, the PLMDM performs as the 1553 Bus Controller (BC) and the AMS functions as a 1553 Remote Terminal (RT).

This link carries the AMSHK stream and Critical Health Data to be down linked, and AMSCMD, which is being up linked.

Note: The RT address for the S3 Upper Inboard PAS (PAS 2) is RT21. This is per Boeing Document, D-684-10500-02, Command and Data Handling Architecture Description. This is located on the LB PL-1 Bus.

8.1.1 Down Link Telemetry (House Keeping Data)

The AMSHK stream and Critical Health data are created by AMS-02 and down linked via this path. This data is carried as what NASA calls “Health and Status” data.

As required by NASA, AMS-02 utilizes CCSDS headers for this link complete with secondary headers (SHF must be set). In addition to the CCSDS header a subset id header and other data is present in the packet.

The frame size of data (including all headers) carried on this link is nominally 2560 bytes (this can be a max of 2560 bytes).

The PLMDM uses a Payload MDM Configuration File (PCF) to know how many words of Health and Status to acquire. This is defined in PDL Screen A-22 as a byte count not including the eight-word CCSDS header. Frames are polled at 1 Hz.

The data down linked ¹⁵is delivered by MSFC-HOSC via TReK to the AMS POCC. (See paragraph 12.1.2).

The following describes the mechanics of transferring data over this link:

The down linked is performed by the PLMDM Payload Health and Status (PHS) service.

¹⁵ CHD is also delivered independently by HOSC to TReK.

The PLMDM operates on a one second processing cycle with ten processing frames. During each of the one-second processing cycles the PLMDM can read one CCSDS packet of data from AMS-02 (as shown below). A “Broadcast Sync With Data” mode command is issued at the start of each 100-millisecond processing frame. The CCSDS packet of data is transferred using multiple reads to a single sub-address in sets of four within each 100-millisecond processing frame. The sets of four reads continue during subsequent 100-millisecond processing frames until the entire CCSDS packet is transferred.

	15	14	13	12	11	10	9	8	7	6	5	4	3	2	1	0	
1	VersionID			Type	SHF	APID											CCSDS Primary
2	Seq Flag		SequenceNo														
3	PacketLen																
4	TimeMSB																CCSDS Secondary
5	TimeLSB																
6	FineTime						TimeID	CHK	NOE	PacketType							
7	Spare	ElementID			PacketID1												HS Header
8	PacketID2																
9	SubsetID																
10	ServiceRequestID																
11	ServiceRequestData																
12	CautionWarning																
13	FBI	AMSequence														AMS	
14	FrameStatus			Link1StBlock													AMS
15	CHD - 10 bytes																AMS Sec
25																	AMSBlock(s)
//																	
n																	
	15	14	13	12	11	10	9	8	7	6	5	4	3	2	1	0	

Figure 23 ISS House-Keeping Data Format

Item	Valid Values	AMS-02 Usage	Comment
SubsetID	0x134 (308)	Set to program assigned value	Program assigned values-AMS-02: 308 ACOP: 309
ServiceRequestID	0-65535	Set to zero	Not used. Must be zero.
ServiceRequestData	0-65535	Set to zero	Not used. Must be zero.
CautionWarning	TBP	TBD	
CHD			See Section 14

Figure 24 Values in ISS House-Keeping Data Format

The ISS overhead values (SubsetID, ServiceRequestID, ServiceRequestData, and CautionWarning) match with SSP57002C Figure 3.2.2.2-1¹⁶.

8.1.2 Commanding (Up Link Telemetry)

This link carries the AMSCMD Data Stream.

Command data consists of AMS Frames (with CCSDS headers and containing AMS Blocks). Command data is framed using a frame size of 124 bytes (inclusive of headers and check words). The CCSDS Secondary is required. The AMS Secondary Header is not required or present.

The command data originates from either JSC/MSFC ground equipment (predefined “fixed” commands) or from the AMS-02 POCC (any form of command). The AMS-02 POCC delivers commands to MSFC via TReK.

All ground commands are up linked to ISS and delivered to the PLMDM for transmission on 1553. Commands can originate on board for ISS facilities (PCS and Timeliner).

The PLMDM design limits the over all command rate to AMS-02 to 10 commands/second. AMS-02 ground segment systems must enforce this limit.

By definition command data is two 1553 messages (or sub-addresses). The PLMDM always transmits both sub-addresses within one processing frame to two consecutive sub-addresses (see: Figure 29 PLMDM Address Assignments).

8.1.3 PLMDM 1553 Command Data Layout Implementation Details

Figure 25 and Figure 26 shows the layout of the 1553 blocks received by AMS-02 for PLMDM commands. **Note:** this does not contain a “valid AMSFrame” since NASA injects a “Reserved Word” and “Legal Station Mode”.

¹⁶ SSP57002C Figure 3.2.2.2-1 is incorrect in that it does not include the H&S Cycle Counter and the Payload Message words. The 57002 book manager has been notified and a PIRN should be forthcoming.

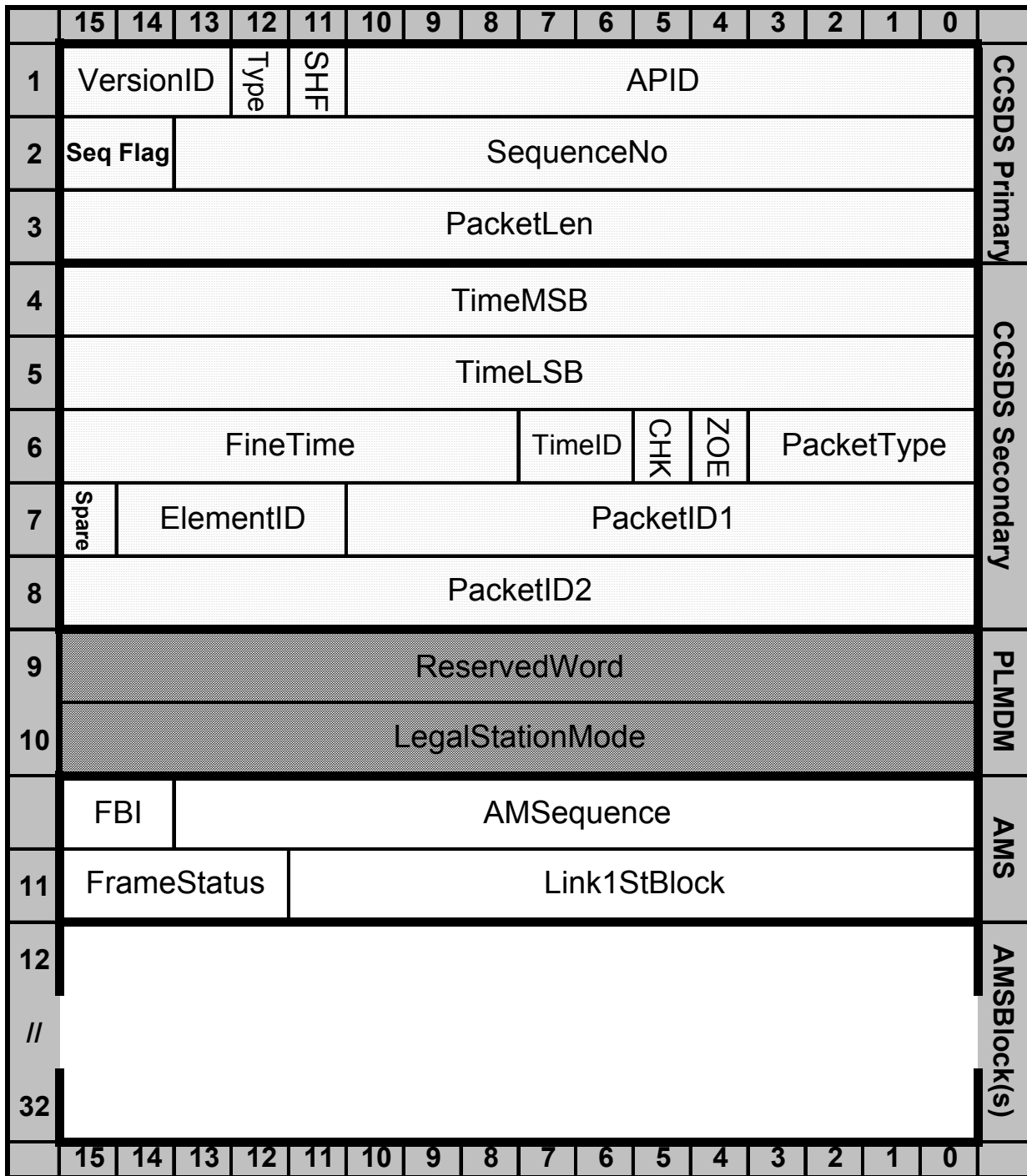

Figure 25 PLMDM Command 1st 1553 Sub Address Block

All values, unless discussed below, are as per section 3.2.

Item	Valid Values	AMS-02 Usage	Comment
------	--------------	--------------	---------

Item	Valid Values	AMS-02 Usage	Comment
PacketLen	41-121	CCSDS length	Note: ground commands are a minimum of 24 1553 words long (11 words of overhead plus a minimum of 13 words of AMS defined command data).
PacketType	See Section 3.3	Ignored	0x0A - RT/Payload Command
PacketID2	ISS assigned “Subset ID” from PDL	TBD	For commands this value contains the AMS-02 “Subset ID”. 0x134 (308)
ReservedWord	TBD	Ignored	
LegalStationMode	Per comments	Ignored	Legal Station Modes: (Each bit means the command is valid when the station is in that mode) 1 Standard 2 Micro-gravity 4 Re-boost 8 Proximity ops 16 External ops 32 Survival 64 ASCR
CheckWord	Any	The value is validated and if incorrect the command is ignored.	The CheckWord immediately follows the last valid word of the command (based on the CCSDS PacketLen).

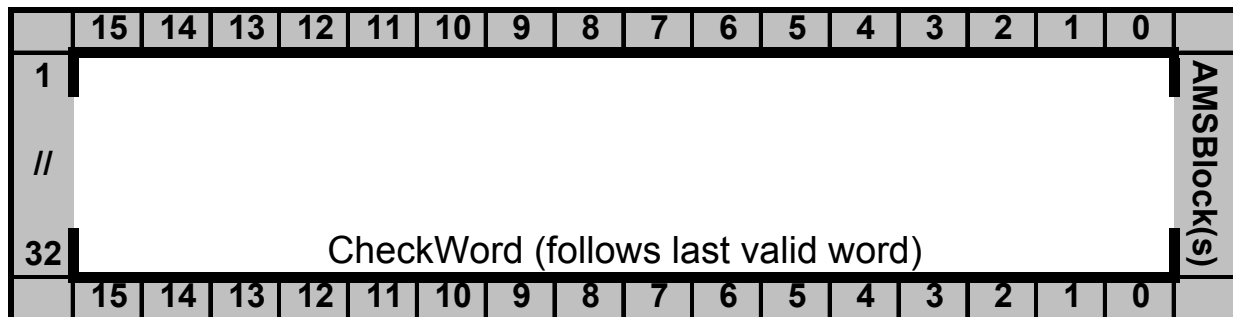

Figure 26 PLMDM Command 2nd 1553 Sub Address Block

All values, unless discussed below, are as per section 3.2.

8.1.4 Time Distribution

The broadcast time signal will be updated once per second and is accurate to ± 2.5 ms with respect to the Global Positioning System (GPS) receiver.

The time broadcast is at sub-address 0x29. The format is specified below

Word #	Description	
1	CCSDS Preamble field '01010000'B	Most significant 8 bits of BCD Year field, range 19-20

Word #	Description	
2	Least significant 8 bits of BCD Year field, range 0-99	BCD Month field, 8 bits, range 1-12
3	BCD Day of Month field, 8 bits, range 1-31	BCD Hours field, 8 bits, range 0-23
4	BCD Minutes field, 8 Bits, range 0-59	BCD Seconds field, 8 Bits, range 0-59
5	Spare, <u>12 bits</u>	Binary Sub seconds Most Significant <u>4-bits</u>
6	Binary Sub-seconds continued - least significant 16 Bits, total range = 0 to 1,048,575 at one microsecond per count	
7	UTC Conversion Parameters, 16 bits, range 0-65,535 Always set to zero. Note this data is contained in Broadcast Ancillary Data	
8	Non CCSDS Seconds/Sub-seconds, 16 bits, range 0-65,535 The one's portion of the seconds plus the sub-seconds information of the CCSDS time converted to a straight binary count rounded to the nearest 256 microseconds (LSB = 256 μ seconds)	

Figure 27 PLMDM Broadcast Time Format¹⁷

8.1.5 ISS Time Management

SSP 41154 Rev E section 3.7 was used as the reference for how time is managed on ISS.

It indicates that “local reference time” (LRT) is maintained by MDMs using CCSDS format. This format is a BCD calendar time representing year, month, day, hour, minute, seconds, and eight bits of binary sub-seconds (about 4 milliseconds).

The Primary C&C MDM is the station master time source. The Primary C&C MDM has two time sources: The Service Module based on ANS (Russian GPS) and the GN&C MDM (based on GPS). The Primary C&C MDM uses its internal clock (no description seen) to maintain its LRT. It can be commanded to “Sync to External Time Source”. This can be either a “jump to time” or a “gradual correction”. It appears (but is not clearly stated) that the “gradual correction” command is persistent and keeps the Primary C&C LRT in sync with the external time source.

The Primary C&C MDM distributes its LRT to the secondary MDMs via broadcast time messages every second on the 1553 buses to which it is attached. The MDMs at this secondary level use drift compensation (described below) and a transmission delay constant (unique to the MDM) to correct their LRT to the observed station master time. This LRT at the secondary level is in turn transmitted to “Tier 3 processors”.

The MDM drift compensation logic maintains the LRT within 100 microseconds of the broadcast times. If the LRT differs from the time broadcast by more than 350 microseconds for 3 consecutive seconds, then the MDM declares itself out of sync.

¹⁷ SSP41175-02 Revision F Table 3.3.2.2.2-1

The ground can send a “Sync to BIA” command to such an MDM to force it to resynchronize with its bus controller. There is no “automatic” sync indicated by this document.

8.1.6 Broadcast Ancillary Data

The ISS system provides certain ancillary data on a broadcast basis to all payloads. Included are such interesting items as the attitude vector.

8.1.6.1 Attitude Vector

Used to determine entry and exit from the South Atlantic Magnetic Anomaly.

8.1.6.2 Solar Array Position

Used to determine impingement of solar array into the field of view.

8.1.7 Critical Health Data

The Critical Health Data is marked as “ISS Safety Data” and transmitted down the S-Band link for more continuous coverage then provided by the house keeping data (which is transferred on the KU-band). See Section 18.

8.1.8 Mode Commands

The following table details the requirements and support for all mode commands. ¹⁸

T/R BIT	MODE CODE	FUNCTION	ASSOCIATED DATA WORD	BROADCAST ALLOWED	IMPLEMENTED By PL/MDM	IMPLEMENTED By AMS	AMS Action
1	00000	Dynamic Bus Control	No	No	No	No	N/A
1	00001	Synchronize W/O Data Word	No	Yes	No	No	N/A
1	00010	Transmit Status Word	No	No	Yes	Yes	TBP
1	00011	Initiate Self-Test	No	Yes	Yes	Yes	TBP
1	00100	Transmitter Shutdown	No	Yes	Yes	Yes	TBP
1	00101	Override Transmitter Shutdown	No	Yes	Yes	Yes	TBP
1	00110	Inhibit Terminal Flag Bit	No	Yes	No	No	N/A
1	00111	Override Inhibit Terminal Flag Bit	NO	Yes	No	No	N/A
1	01000	Reset Remote	No	Yes	Yes	Yes	TBP

¹⁸ SSP52050, Revision D

T/R BIT	MODE CODE	FUNCTION	ASSOCIATED DATA WORD	BROADCAST ALLOWED	IMPLEMENTED By PLMDM	IMPLEMENTED By AMS	AMS Action
		Terminal					
1	01001	Reserved to 01111	No				Ignored.
1	10000	Transmit Vector Word	Yes	Yes	Yes	Yes	TBP
0	10001	Synchronize With Data Word	Yes	Yes	Yes	Yes	Used to sync to frame. See note ¹⁹ .
1	10010	Transmit Last Command	Yes	No	Yes	Yes	TBP
1	10011	Transmit BIT Word	Yes	No	Yes	Yes	TBP
0	10100	Selected Transmitter Shutdown	Yes	Yes	No	No	N/A
0	10101	Override Selected Transmitter Shutdown	Yes	Yes	No	No	N/A
0	10110	Reserved to 11111	Yes				Ignored.

Figure 28 AMS Mode Code Implementation For PLMDM

8.1.9 PLMDM Sub-Address Assignments

SA#	Transmit (T/R=1)	Receive (T/R=0)
0	Mode Code (SAM=00000) Command	Mode Code Command
1	Reserved	Reserved
2	Reserved	Reserved
3	Reserved	Reserved
4	Reserved	Reserved
5	Reserved	Reserved
6	Reserved	Reserved
7	Reserved	Ancillary Data
8	Low Rate Telemetry Data (Not used)	Command, Request Response (1)
9	Health and Status Data	Command, Request Response (2)
10	Reserved	Reserved
11	Reserved	Reserved
12	Reserved	Reserved
13	Reserved	Broadcast Ancillary Data (1)
14	Reserved	Broadcast Ancillary Data (2)
15	Reserved	File Transfer (Not used)

¹⁹ Format of this word is given in Table 3.3.2.2.1-1 of SSP 41175-2

SA#	Transmit (T/R=1)	Receive (T/R=0)
16	Reserved	File Transfer (Not used)
17	File Transfer (Not used)	File Transfer (Not used)
18	File Transfer (Not used)	File Transfer (Not used)
19	File Transfer (Not used)	File Transfer (Not used)
20	File Transfer (Not used)	File Transfer (Not used)
21	File Transfer (Not used)	File Transfer (Not used)
22	File Transfer (Not used)	File Transfer (Not used)
23	File Transfer (Not used)	File Transfer (Not used)
24	File Transfer (Not used)	Reserved
25	File Transfer (Not used)	Reserved
26	Reserved	Reserved
27	Reserved	Reserved
28	Reserved	Reserved
29	Reserved	Broadcast Time
30	Reserved (Data Wrap Read)	Reserved (Data Wrap Write)
31	Mode Code (SAM=11111) Command	Mode Code Command

Figure 29 PLMDM Address Assignments ²⁰

8.2 ISS AMS-02 HRDL Utilization

AMS-02 has two prime targets for HRDL transfers. The first is the High Rate Frame Multiplexer (HRFM - via the High-Rate Communications Outage Recorder (HCOR)). The HRFM interleaves data to the KU-Band transmission system for downlink. The second target is the AMS-02 Crew Operations Post (ACOP) which provides an onboard recording of AMS-02 data. The APS can be configured to tee data transmitted by AMS-02 to both the HRFM and ACOP.

Nominally there should be a dedicated (24x7x365x3) link for both transmit and receive between AMS-02 and ACOP. A link between ACOP and HRFM can be configured based upon program scheduling for AMS-02 downlink.

The AMS-02 HRDL link nominally carries the AMS-02 Science Data Stream and a second copy of AMS-02 House Keeping Data Stream.

8.2.1 HRDL Protocol and Framing

AMS-02 utilizes the Consultative Committee for Space Data Systems (CCSDS) Packet protocol for all systems, including HRDL. (The bit-stream protocol is not supported.)

JIM-HRDL implements fixed size frames (per “session”) of not more than 4095 bytes. In order to change its frame size JIM-HRDL must be reset and reconfigured, disrupting any activity on the HRDL link and starting a new “session”.

²⁰ SSP52050, Revision D – Table 3.2.3.2.1.4-1

8.2.2 AMS-02 HRDL Transmissions

AMS-02 only has a single HRDL transmit connection. The supported connections via the APS for this connection are

- No connection
- Connection to ACOP
- Connection to HRFM for KU-Band transmission
- Connection to both HRFM for KU-Band transmission and to ACOP

This link carries the following data streams: AMSHK (a second copy), AMSSCI, ACOPCMD, and ACOPREPLY.

Note: Strictly speaking by ISS documents, an APID represents a single simplex point-to-point link. AMS-02 utilizes APIDs to delineate data streams. The connection between AMS-02 and ACOP by HRDL represents a private payload-to-payload connection and as such is not governed by ISS requirements. On this link AMS-02 reuses the APIDs ACOPCMD and ACOPREPLY to provide a symmetrical link. However due to the APS tee function the ACOPCMD and ACOPREPLY streams will appear in ISS traffic to the KU-Band. Since the ISS program does not see the ACOP to AMS-02 traffic this should be fine.

8.2.3 AMS-02 HRDL Reception

AMS-02 has a single HRDL receiver connection. The supported connections via the APS for this connection are:

- No connection
- Connection to ACOP

This link carries the following data streams: ACOPREPLY, ACOPCMD

8.2.4 AMS-02 HRDL Data Layout Implementation

Figure 30 documents the HRDL data layout.

	15	14	13	12	11	10	9	8	7	6	5	4	3	2	1	0	
1	VersionID			Type	SHF	APID											CCSDS Primary
2	Seq Flag		SequenceNo														
3	PacketLen																
4	TimeMSB																CCSDS Secondary
5	TimeLSB																
6	FineTime						TimeID	CHK	ZOE	PacketType							
7	Spare	ElementID			PacketID1												
8	PacketID2																
9	FrameStatus			Link1StBlock													AMS
10																	AMS Bkls
2042																	
	15	14	13	12	11	10	9	8	7	6	5	4	3	2	1	0	

Figure 30 HRDL Data Layout Implementation

EMU File Transfer Request	RIC	PLD	Async	Ethernet
PLD File Transfer Request	RIC	PLD	Async	0x0042
PLD File Transfer Data Block	RIC	PLD	Async	0x00A4

Figure 33 EXPRESS Header Message Types

9.3 ACOP Commanding

ACOP commands are up-linked to the RIC in the same fashion as the commands are sent to AMS-02 via the PLMDM. The figure below shows the relationship of the commands sent from the ground to the RIC and those the RIC sends to the ACOP.

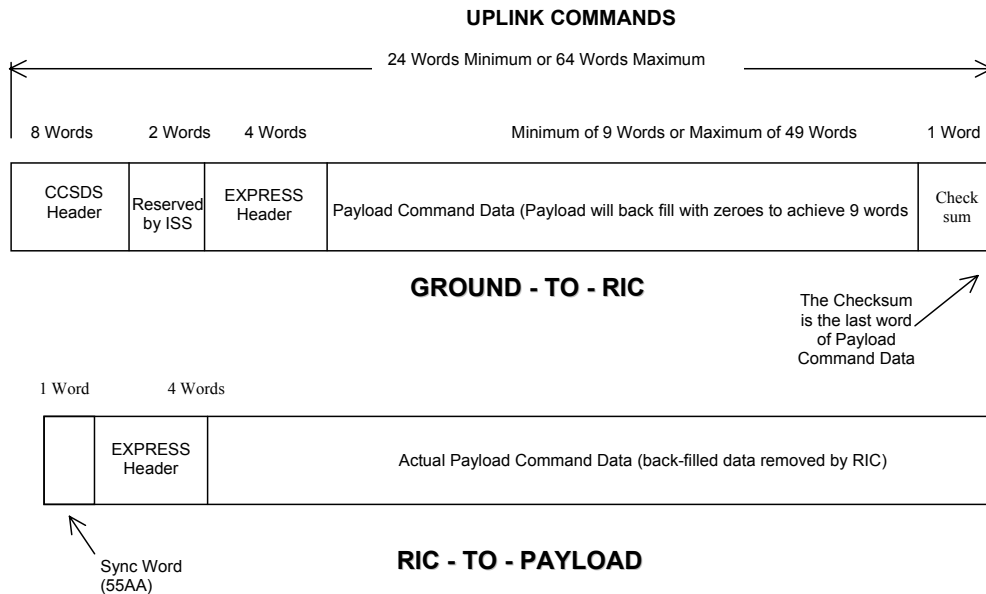
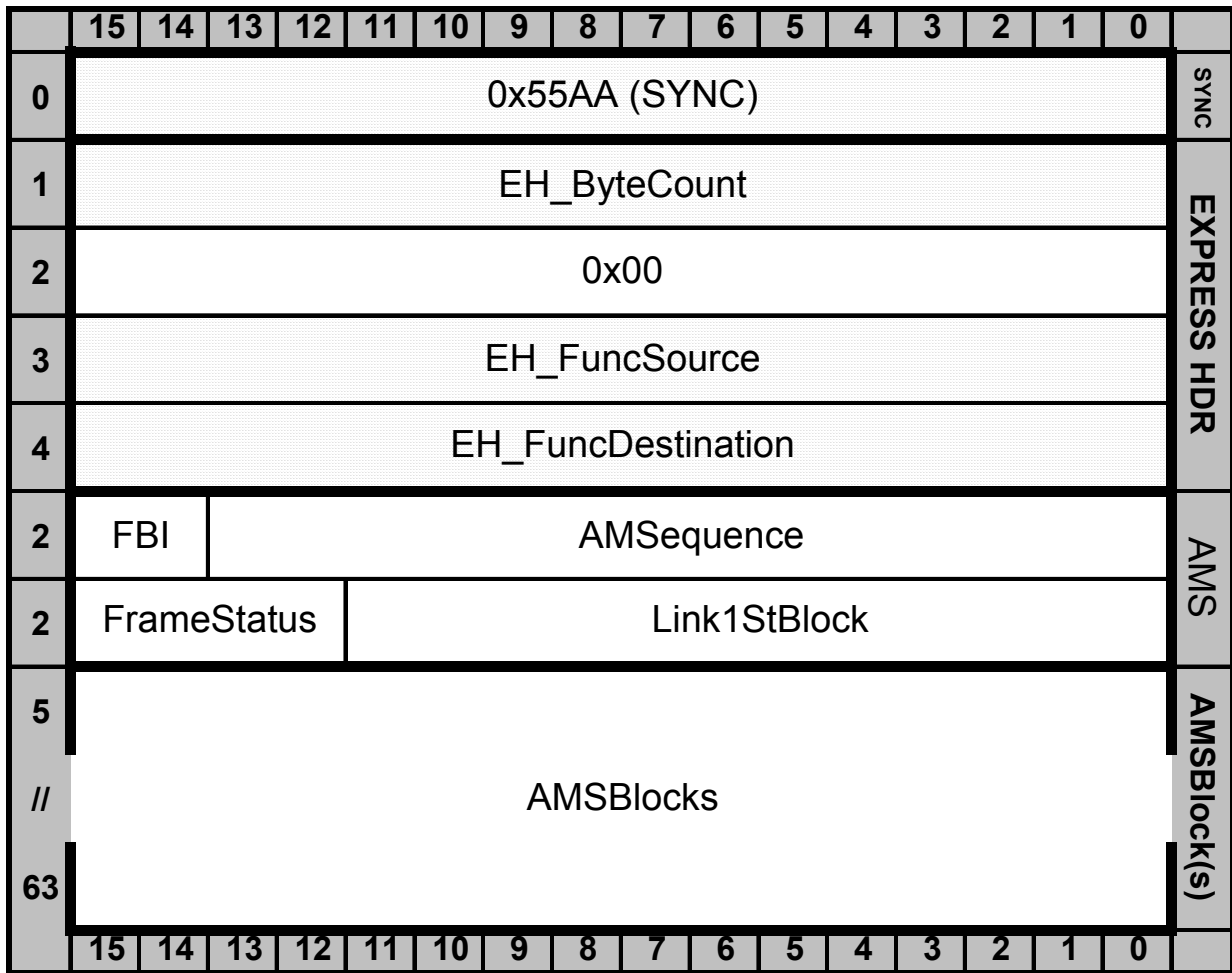

Figure 34 Ground to RIC to ACOP Command Layout

The payload command data words in PDL include the EXPRESS Header and the payload command data words, but not the sync word.

The RIC receives the command from 1553, compares the actual received number of words with the CCSDS packet length in Word 3, and checks the CCSDS checksum word. The RIC uses the length in the CCSDS header for verifying the received command length and uses the "Message Byte Count" in the first word of the EXPRESS Header for verifying the actual number of payload command byte(s). After the verification process the RIC issues the payload command to the destination Function Code. The RIC removes the CCSDS header, fill words, and checksum. The contents of the command message received by the payload will be the sync word at the beginning of the packet, EXPRESS Header, and the payload command data words. For an RS-422 payload the RIC will add the serial checksum word at the end of the message before sending it out to the payload. The sync word added by the RIC is not part of the command message. The Message Type is not used by the RIC and can be used by the payload for its own purpose as long as the contents are between 0100 to FFFE.



Item	Valid Values	AMS-02 Usage	Comment
EH_ByteCount	6-94	EXPRESS packet byte count	Not clear how this must relate to the CCSDS packet length.
FrameStatus		Logical OR of valid values as appropriate	0bxxx1: AMSSHf is required to be set to meet EXPRESS requirements
Link1StBlock			See Figure 5 AMS Frame Headers And Frame Checksums

Figure 35 EXPRESS Command Envelop

9.4 ACOP Health and Status Data

ACOP provides Health and Status (including Safety) data to the RIC at a rate of 1.0 Hz, continuously, while ACOP is powered on. The Health and Status data has a fixed length of 92 16-bit words (including Emergency, Caution, and Warning (ECW) word). The sync word, the 4 words of EXPRESS Header, and any RS-422 serial checksum word are not counted as part of the 92 words.

The first word of Health and Status data is reserved by ACOP as the ECW word. ACOP uses parameter monitoring as the primary means of fire detection and sets the ECW word to indicate potential for fire. The integer 1 (Advisory) will be located at the most right bit (last transmit bit) in the 16-bit word.

ACOP provides as the second word of Health and Status data a H&S Cycle Counter. The H&S Cycle Counter shall be an unsigned 16 bit integer in the range of zero to 65,535. The H&S Cycle Counter shall be set to zero for the first H&S packet that the payload transmits. The H&S Cycle Counter shall be incremented by a value of one for each H&S packet transmitted. Once a value of 65,535 is reached, the H&S Cycle Counter for the following packet shall be reset to a value of zero and then the payload will continue incrementing the H&S Cycle Counter as noted above. This H&S Cycle Counter will be used by payload operations personnel to determine whether H&S data being received is stale.

The RIC receives ACOP's Health and Status data and verifies the correct EXPRESS Header with message type as 009Bh. After the verification process the RIC removes the sync word, EXPRESS Header, and serial checksum word (RS-422 payload only) and adds the Subset ID, Service Request Word, and Service Request Data for each payload. The RIC combines all active payload Health and Status data in the order in which it is received and EXPRESS Subsystem Health and Status data as one EXPRESS Rack Health and Status message sent to the PL MDM at 1-Hz rate. The Subset ID word is always needed and the spaces for the Service Request ID and Service Request data words are reserved (zero filled when no request is present from the payload).

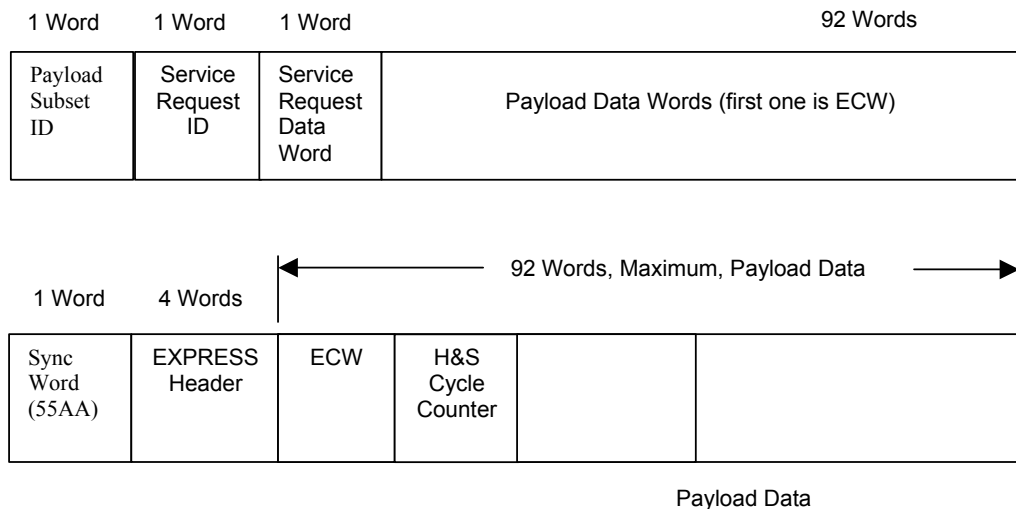
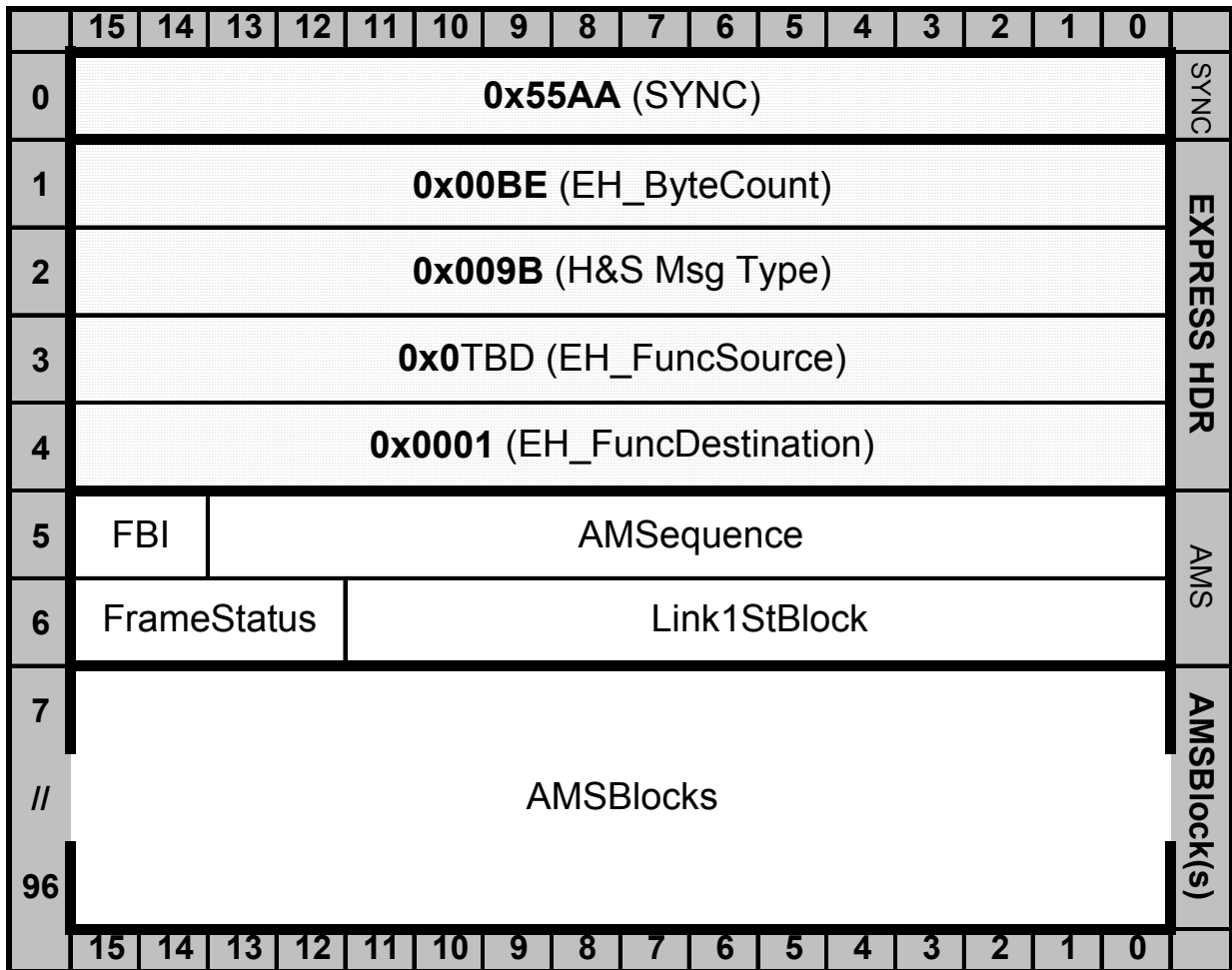

Figure 36 ACOP Health and Status Layout



9.5 ACOP HRDL Utilization

TBP

9.6 ACOP MRDL Utilization

TBP

9.7 ACOP Time Synchronization

ACOP requests the time from the RIC periodically using the following command:

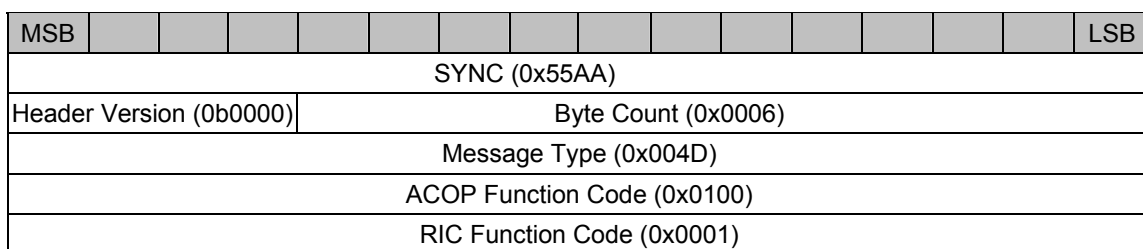

Figure 37 ACOP Time Request

10 KSC Phase Ground Segment Interfaces

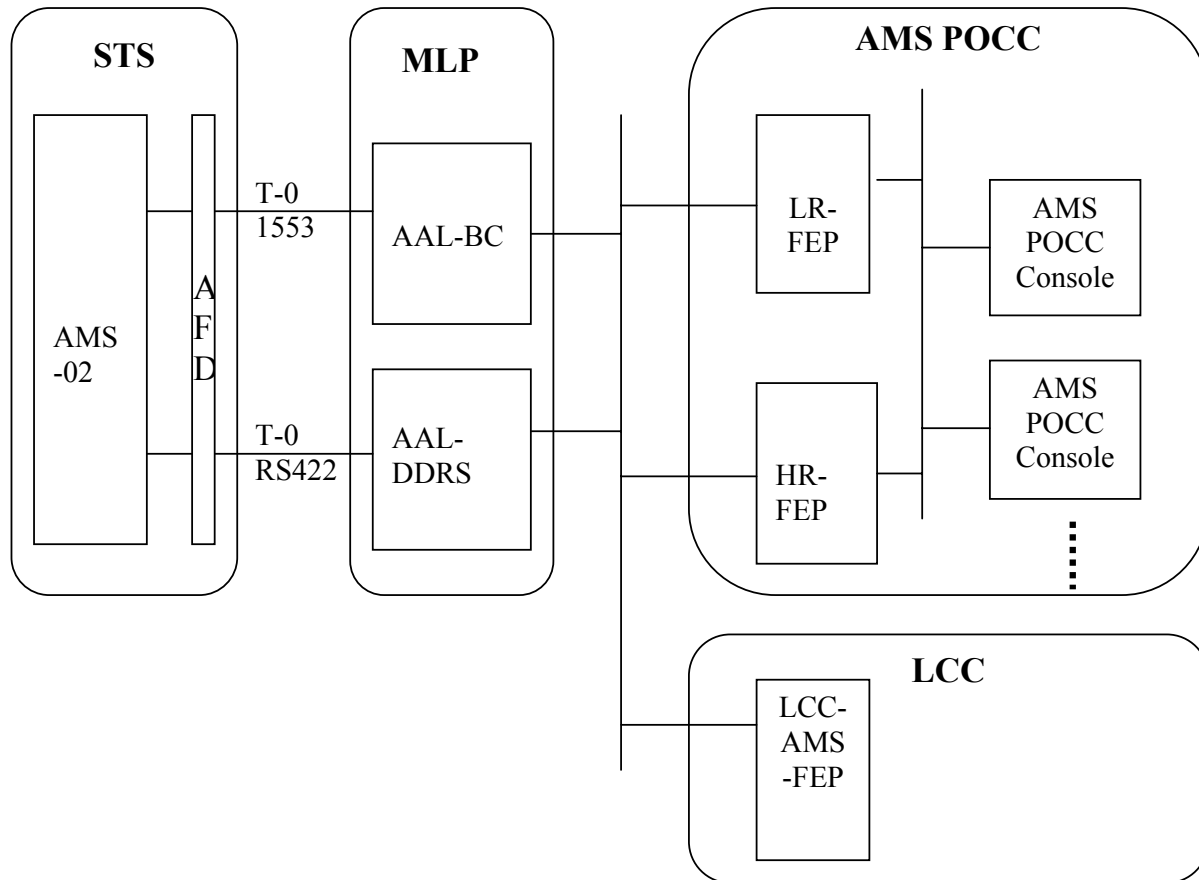

Figure 39 KSC Ground Interfaces

10.1 1553 Support

The AMS-02 1553 bus can optionally be switched to the T-0 cable. Prior to launch this switch option will be selected providing connectivity to room 10A in the mobile launch platform. AMS provided GSE will be used to receive and distribute the 1553 data from this location during pad operations.

Both command and H&S data layouts are per the OIU implementation as discussed in Section 7.1

The AMS GSE must provide data distribution for the pre-launch data to both the AMS-02 POCC as well as the launch control systems for launch commit at T-9 minutes.

10.2 RS422 Support

The AMS-02 RS422 cable will be patched to the T-0 cable at the aft flight deck prior to launch providing connectivity to room 10A in the mobile launch platform. AMS provided GSE will be used to receive and distribute the RS422 data from this location during pad operations.

10.3 Launch Commit Criteria

During pad operations data from both RS422 and 1553 are distributed to the KSC launch control to provide monitoring of the safety critical launch commit criteria. Details are provided as a separate document.

11 STS Phase Ground Segment Interfaces

Needs review and work:

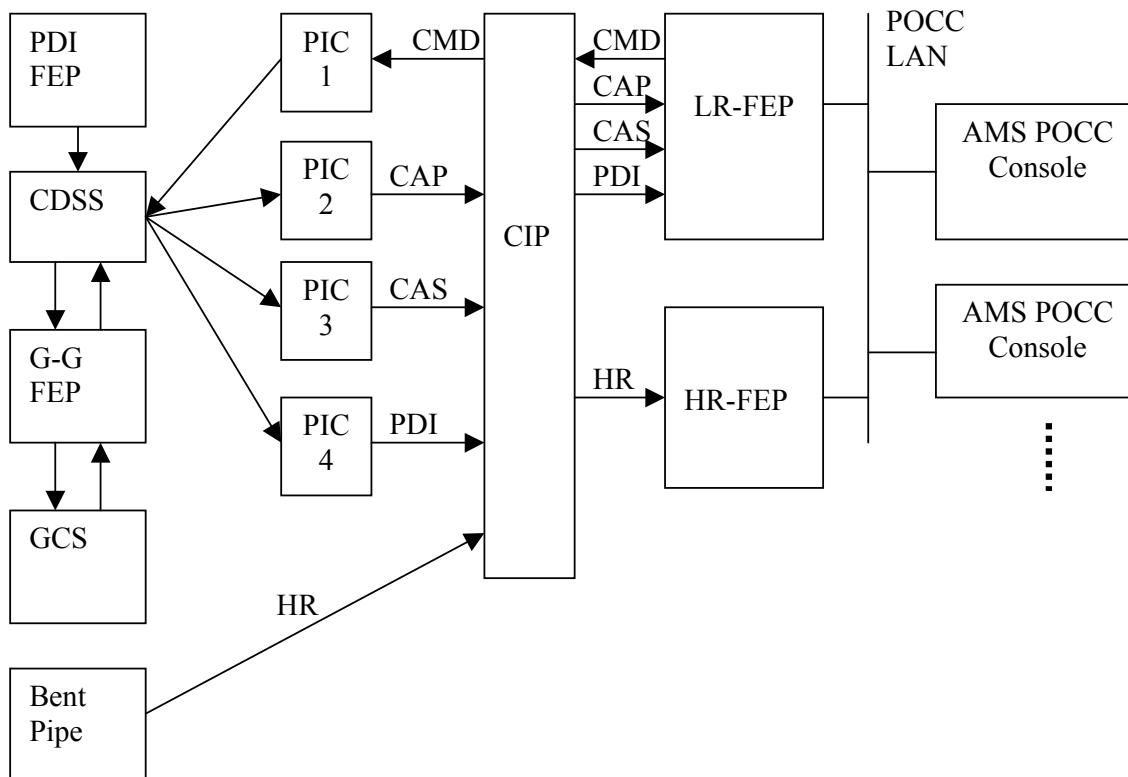

Figure 40 STS Phase POCC Connections

11.1 JSC Customer Interface Panel (CIP)

The JSC generic POCC customer interface panel (CIP/Walker box) is documented in NSTS-21063 Rev E starting at page F-10.

General RS422 requirements include:

- Synchronous NRZ-L to 10mb/s
- Programmable sync pattern
- Flipping of MSB and LSB
- Accept independent inversions of either clock or data signals
- No hand shaking or control signals
- 124 Ohm termination

General RS232 requirements include:

- Baud rate: 300 - 38.4 kbaud
- Data bits: 8
- Stop bits: 1, 2
- Parity: Even, Odd, None
- Handshake: None, Hardware

11.2 Low Rate Front End Processor (LR-FEP)

The LR-FEP provides the AMS-02 POCC LAN with interfaces to send commands and receive various low rate data. Communication between the LR-FEP and NASA systems is performed in NASCOM blocks as discussed in the JSC POCC Capabilities Document (PCD - NSTS-21063-POC-CAP) in Appendix L.

The LR-FEP uses the Payload Interface Converter (PIC)²¹ as a demultiplexer and physical media converter.

11.2.1 AMS-02 Health and Status via STS OIU

Details of the OIU PDI frame structure are in Section 7.1.3.

The AMS-02 HK data during STS operations is transmitted as part of the Operational Data (OD) and is received as the “PDI Frame Set”.²² The PDI Frame Set is “striped and shipped” by the PIC. This data is delivered to the LR-FEP as NASCOM blocks using the following communications parameters:

Synchronous 38400 (TBR)

11.2.2 Customer Auxiliary Service (CAS)

The Mission control systems report various auxiliary information via CAS. CAS is delivered to the AMS-02 LR-FEP via the PIC as NASCOM blocks using the following communications parameters:

Asynchronous 38400 E81 (TBR)

11.2.3 Command Data

Command data (CMD) is formatted as CCSDS packets of data per Section 7.1.5. The command CCSDS packet is enclosed in an OIU envelop as shown below.

²¹ See NSTS-21063-POC-CAP Appendix K.

²² See NSTS-21063 “POCC Capabilities Document” Rev E 16-Aug-03 for details.

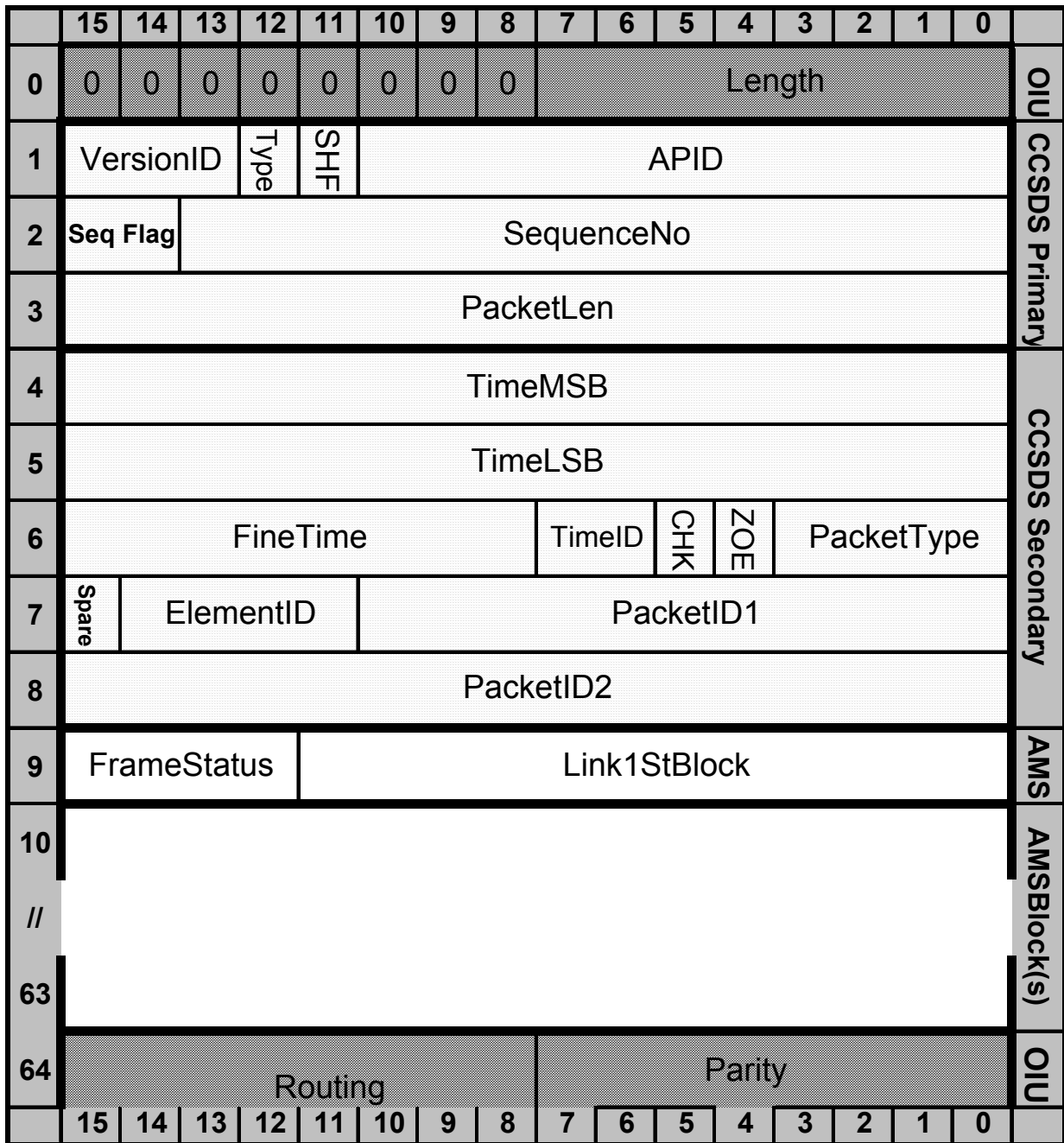

Figure 41 OIU Command Envelop

Item	Valid Values	AMS-02 Usage	Comment
Length	0-124	Ignored	Number of bytes of PSP data in this frame.
PacketLen	0-100	Length of CCSDS packet	See: section 3.3
CHK	1	1	CCSDS CheckWord is required.

Item	Valid Values	AMS-02 Usage	Comment
CheckWord	0-65535	Checked. Commands with invalid CheckWords are ignored.	16-bit add without carry checksum. Follows last word of CCSDS valid packet.
Routing	0-255	Ignored.	OIU the logical destination of the command. (Fixed value, always "AMS's number" Was 7 on STS91). Commands to OIU are Routing = 0.
Parity	0-255	Computed and validated. Commands in error are ignored.	Odd parity is calculated on a columnar basis of the first byte through the Routing byte.

Figure 42 OIU Command Envelop Values

The following is an example of computing the PSP Block parity.

0004	0	0	0	0	0	0	0	0	0	0	0	0	0	1	0	0
00FF	0	0	0	0	0	0	0	0	1	1	1	1	1	1	1	1
E0E4	1	1	1	0	0	0	0	0	1	1	1	0	0	1	0	0

00	0	0	0	0	0	0	0	0	8 Zeros
04	0	0	0	0	0	1	0	0	Byte count
00	0	0	0	0	0	0	0	0	
FF	1	1	1	1	1	1	1	1	
E0	1	1	1	0	0	0	0	0	Routing
E4	1	1	1	0	0	1	0	0	Parity
	1	1	1	1	1	1	1	1	Odd Parity

Figure 43 OIU Parity Example

The CCSDS packets for commands are delivered by the LR-FEP to the MCC via the PIC interface as NASCOM blocks in a serial data stream using the following communications parameters:

Asynchronous 38400 E81 (TBR)

The command rate is limited to one command per two seconds by MCC systems.

11.2.4 Command Acceptance Patterns

The Mission control systems report the status of commands submitted via the Command Acceptance Patterns (CAP). The CAP are delivered to the AMS-02 LR-FEP via the PIC as NASCOM blocks using the following communications parameters:

Asynchronous 38400 E81 (TBR)

11.3 High Rate Front End Processor (HR-FEP)

11.3.1 AMS-02 Science Data Via STS KU-Band

The AMS-02 RS422 data is received as a Independent Payload Data Stream (IPDS) “KU-Band bent pipe data” at the CIP.

Note: There are dire warnings about the possible independent inversion of the clock and data signals (on an AOS to AOS basis) on this link. These should be investigated as it is known that the STS 91 data systems compensated for this and the Digiboards can not

Per NSTS-21063-POC-CAP Rev E

Page F-11

“b. The interface must have a programmable sync pattern. For Independent Payload Data Streams (IPDS), a sync pattern is not mandatory. IPDS data must have autopolarity data correction.”

Page F-13

“e. It is recommended that the user EGSE be able to accept inverted data and clock.”

12 ISS Phase Ground Segment Interfaces

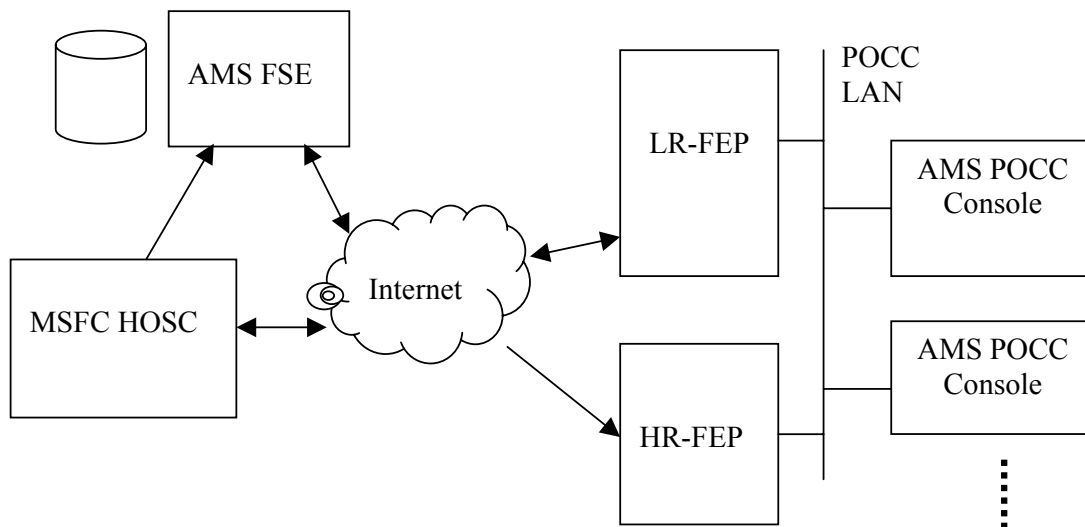

Figure 44 ISS Ground Segment

12.1 MSFC – HOSC

This section under development.

12.1.1 FSE At HOSC

Data that is sent by AMS-02 directly to the HRDL system will be received and recorded by FSE at the MSFC HOSC. Once recorded this data will be distributed over the Internet to the AMS-02 Payload Operations Control Center (POCC) and the Science Operations Centers (SOCs). The following lists the APIDs and a description of each data set that the FSE equipment must record and provide network distribution of.

1. AMSSCI - AMS-02 Science Data
2. AMSHK – AMS-02 Housekeeping data
3. AMSHKH - AMS-02 Housekeeping Data, HRDL copy
4. PBCKHK – ACOP Playback of AMS-02 Housekeeping data
5. PBCKSCI - ACOP Playback of AMS-02 Science Data
6. ACOPHK – ACOP Housekeeping data
7. ACOPQC – AMS-02 quality control data

The HOSC system will be configured to transmit these APIDs by TBD.

12.1.2 TReK Interfaces To HOSC

The Telescience Resource Kit (TReK) will be utilized as a command server and to retrieve and configure certain datasets.

1. AMS-02 Commands (command server and simple web interface)

2. ACOP Commands (command server and simple web interface)
3. Critical Health Data (reception of and web interface)

13 Commands For AMS-02

This section provides the details of commanding AMS-02.

13.1 Externally Defined AMSBlocks

The following AMSBlocks are defined for use within fixed commands externally defined to ISS/NASA. These are conceived to allow these external organizations to control AMS-02 in the event of interruption of service of the AMS-02 POCC, network interruptions, or other contingencies. They are by no means a robust set of AMS-02 commands. They are intended to provide the ability to control AMS-02 assuming AMS-02 is operating nominally and has valid configuration values within its configuration files.

The externally defined AMSBlocks operate by addressing the MDC broadcast NodeAddress using DataTypes handled specially by AMS-02.

The AMSBlocks defined below are constructed into AMSFrames within the Payload Data Library (PDL) system and can be issued at anytime by NASA systems.

These commands can thus be:

- Injected into the command stream at anytime (they are marked with a unique FrameStatus bit)
- Are only a single 1553 command cycle (53 words or less)

13.1.1 Startup Notification AMSBlock

The PLMDM will issue a command frame containing this AMSBlock when the payload is started into operation.

Field	Value	Comment
BlockLength	0x0006	Two bytes of parameter
BlockType:	0x01	Put then get
NodeAddress:	0x17	JMDC Broadcast
DataType:	0x1F0101	Data type is the PDL command ID
Parameter:	0x0000	Ignored

Hex AMSBlock: 0x0006 0xC2FF 0x0101 0x0000

Figure 45 Startup Notification AMSBlock

13.1.2 Shutdown Notification AMSBlock

The PLMDM will issue a command frame containing this AMSBlock when the payload is shutdown.

Field	Value	Comment
BlockLength	0x0006	Two bytes of parameter
BlockType:	0x01	Put then get
NodeAddress:	0x17	JMDC Broadcast

DataType:	0x1F0102	Data type is the PDL command ID
Parameter:	0x0000	Ignored

Figure 46 Shutdown Notification AMSBlock

Hex AMSBlock: 0x0006 0x82FF 0x0102 0x0000

13.1.3 Operations Standby AMSBlock

The PLMDM will issue a command frame containing this AMSBlock when the payload is placed in standby.

Field	Value	Comment
BlockLength	0x0006	Two bytes of parameter
BlockType:	0x01	Put then get
NodeAddress:	0x17	JMDC Broadcast
DataType:	0x1F0103	Data type is the PDL command ID
Parameter:	0x0000	Ignored

Figure 47 Operations Standby AMSBlock

Hex AMSBlock: 0x0006 0x82FF 0x0103 0x0000

13.1.4 Magnet Watch Dog Set AMSBlock

The AMS-02 magnet has a watchdog timer, the purpose of which is to ramp down the magnet in the event of AMS-02 losing power or communications. The timer value is decremented once per second. If it is not set on a timely basis (if it is allowed to run down to zero), the magnet is ramped down. If unintended, this has a substantial negative effect on AMS consumables and consequently mission success. This AMSBlock sets the magnet watchdog timer with a new time.

Field	Value	Comment
BlockLength	0x0006	Two bytes of parameter
BlockType:	0x01	Put then get
NodeAddress:	0x17	JMDC Broadcast
DataType:	0x1F0104	Data type is the PDL command ID
Parameter:	0xXXXX	New WDT parameter in seconds - 0x7080 is eight hours.

Figure 48 Magnet Watch Dog Set AMSBlock

Hex AMSBlock: 0x0006 0x82FF 0x0104 0xXXXX

13.1.5 Set Power Step AMSBlock

AMS-02 hardware does not have per se “power states or steps”. There are many systems and subsystems that can be powered on or off independently. Selecting a “Power Step” requests a programmable pre-configuration of switches to be set. After selecting a Power Step power switches can be changed independently. AMS-02

reports Power Step based solely on a simple scan of the PDB (circuit breaker box) settings.

Field	Value	Comment
BlockLength	0x0006	Two bytes of parameter
BlockType:	0x01	Put then get
NodeAddress:	0x17	JMDC Broadcast
Data Type:	0x01F105	Data type is the PDL command ID
Parameter:	0xXXXX	Which power state to set , see below.

Figure 49 Set Power Step AMSBlock

Hex AMSBlock: 0x0006 0x82FF 0x0105 0xXXXX

Power Steps are authoritatively discussed within the PDB documentation. The following table provides the NASA state code to value mapping.

Value	State Code	Comment
0x0000	STEP 0	The action of setting STEP 0 is not defined.
0x0001	STEP 1	Communication established ONLY
0x0002	STEP 2	Magnet monitoring & control
0x0003	STEP 3	Mission critical elements activated (stable standby)
0x0004	STEP 4	Nominal data taking activated
0x0005	STEP 2A	Magnet charging
0x0006	STEP 3A	Tracker thermal
0x0007	STEP 4A	TBD

Figure 50 Power Step State Codes

13.1.6 Set Operation Condition AMSBlock

AMS-02 has many configuration and parameter values that impact the operation condition. There are a small number of pre-defined conditions.

Field	Value	Comment
BlockLength	0x0006	Two bytes of parameter
BlockType:	0x01	Put then get
NodeAddress:	0x17	JMDC Broadcast
Data Type:	0x1F0106	Data type is the PDL command ID
Parameter:	0xXXXX	Which operations condition to set, see below.

Figure 51 Set Operations Condition AMSBlock

Hex AMSBlock: 0x0006 0x82FF 0x0106 0xXXXX

The following defines the NASA state codes for this command.

Value	State Code	Comment
-------	------------	---------

0x0000	H&S	Health and status data gathering only
0x0001	DAQ	Data acquisition enabled – science data gathering

Figure 52 Operation State Codes

13.1.7 Set Telemetry State AMSBlock

AMS-02 has several paths to send telemetry and several streams of telemetry that can be sent. There are a small number of pre-defined states that can be selected.

Field	Value	Comment
BlockLength	0x0006	Two bytes of parameter
BlockType:	0x01	Put then get
NodeAddress:	0x17	JMDC Broadcast
Data Type:	0x1F0107	Data type is the PDL command ID
Parameter:	0xXXXX	Which operations condition to set, see below.

Figure 53 Set Telemetry State AMSBlock

Hex AMSBlock: 0x0006 0x82FF 0x0107 0xXXXX

The following defines the NASA state codes for this command. **MC: I think this should indicate which streams (APIDs) to turn on/off on which pipe.**

Value	State Code	Comment
0x00	H&S	Health and status data transmission only
0x01	SCI	Science data transmission

Figure 54 Telemetry State Codes

13.1.8 Set Owners AMSBlock

AMS-02 has multiple MDCs (Main Data Computers) each capable of controlling several key resources. These resources are assigned to an “MDC owner” using this AMSBlock.

- 1553 (RT owner)
- HRDL/422
- DAQ
- MCT

Field	Value	Comment
BlockLength	0x0006	Two bytes of parameter
BlockType:	0x01	Put then get
NodeAddress:	0x17	JMDC Broadcast
Data Type:	0x1F0108	Data type is the PDL command ID
Parm1:	0xX...	MDC number for 1553 (0-3 for MDC#)
	0x.X..	MDC for MCT (F do not modify)
	0x..X.	MDC number for HRDL/422 (E unset as owner)

	0x...X	MDC number for DAQ (4-D invalid)
Parm2:	0xY... 0x.Y.. 0x..Y. 0x...Y	(APLS: MDC for UDP owner)

Figure 55 Set Owners AMSBlock

Hex AMSBlock: 0x0008 0x2CFF 0x0108 0xXXXX 0xYYYY

13.1.9 Set Parameter_1 AMSBlock

This AMSBlock is used to set a 16-bit parameter. The nature and values for this parameter are to be defined later.

Field	Value	Comment
BlockLength	0x0006	Two bytes of parameter
BlockType:	0x01	Put then get
NodeAddress:	0x17	JMDC Broadcast
DataType:	0x1F0109	Data type is the PDL command ID
Parameter:		0 – 65535

Figure 56 Set Parameter_1 AMSBlock

Hex AMSBlock: 0x0006 0x2CFF 0x0109 0xXXXX

13.1.10 Set Parameter_2 AMSBlock

This AMSBlock is used to set a 16-bit parameter. The nature and values for this parameter are to be defined later.

Field	Value	Comment
BlockLength	0x0006	Two bytes of parameter
BlockType:	0x01	Put then get
NodeAddress:	0x17	JMDC Broadcast
DataType:	0x1F010A	Data type is the PDL command ID
Parameter:		0 – 65535

Figure 57 Set Parameter_2 AMSBlock

Hex AMSBlock: 0x0006 0x82FF 0x010A 0xXXXX

13.1.11 Set Parameter_3 AMSBlock

This AMSBlock is used to set a 16-bit parameter. The nature and values for this parameter are to be defined later.

Field	Value	Comment
BlockLength	0x0006	Two bytes of parameter
BlockType:	0x01	Put then get
NodeAddress:	0x17	JMDC Broadcast

DataType:	0x1F010B	Data type is the PDL command ID
Parameter:		0 – 65535

Figure 58 Set Parameter_3 AMSBlock

Hex AMSBlock: 0x0006 0x82FF 0x010B 0xXXXX

13.1.12 Set Parameter_4 AMSBlock

This AMSBlock is used to set a 16-bit parameter. The nature and values for this parameter are to be defined later.

Field	Value	Comment
BlockLength	0x0006	Two bytes of parameter
BlockType:	0x01	Put then get
NodeAddress:	0x17	JMDC Broadcast
DataType:	0x1F010C	Data type is the PDL command ID
Parameter:		0 – 65535

Figure 59 Set Parameter_4 AMSBlock

Hex AMSBlock: 0x0006 0x82FF 0x010C 0xXXXX

13.1.13 Set Parameter_5 AMSBlock

This AMSBlock is used to set a 16-bit parameter. The nature and values for this parameter are to be defined later.

Field	Value	Comment
BlockLength	0x00006	Two bytes of parameter
BlockType:	0x01	Put then get
NodeAddress:	0x17	JMDC Broadcast
DataType:	0x1F010D	Data type is the PDL command ID
Parameter:		0 – 65535

Figure 60 Set Parameter_5 AMSBlock

Hex AMSBlock: 0x0006 0x82FF 0x010D 0xXXXX

13.1.14 Ping Node

This AMSBlock is used to ping any node on AMS-02. A ping is simply a request to echo back the contents of the values put to this block.

Field	Value	Comment
BlockLength	0x00006	Two bytes of parameter
BlockType:	0x01	Put then get
NodeAddress:	0xXXX	Node address is “parameter”
DataType:	0x1F0001	Ping data type
Data	0xXXXX	0 – 65535

Figure 61 Set Parameter_5 AMSBlock

Hex AMSBlock: 0x000X 0x8XXX 0x0001 0xXXXX

13.1.15 Boot Node

Each interface within AMS-02, except the LRDL (1553), supports a boot command. This command is used to reset and reboot one (by selection) of four Main Data Computers (JMDC). The firmware in each interface uses well-known key values in each frame to determine if this frame represents a boot command for this computer. The boot command is in fact an AMS Frame containing a normal AMSBlock placed as the first (and only) AMSBlock within the frame.

The following table addresses values are used to determine if a frame represents a boot command.

Field	Tested For	Comments
VersionID		Not tested.
Type		Not tested.
SHF	1	Secondary header must be present
APID		Not tested
SeqFlag		Not tested
SequenceNo		Not tested
PacketLen	Upper four bits must be zero	All frames are less than 4096 bytes
TimeMSB		Not tested.
TimeLSB		Not tested.
FineTime		Not tested.
TimeID		Not tested.
CHK		Not tested.
ZOE		Not tested.
PacketType		Not tested.
Spare		Not tested.
ElementID		Not tested.
PacketID1		Not tested.
PacketID2		Not tested.
FrameStatus	Must equal 0	Must be all zero bits.
Link1StBlock	Must be zero	First AMS block header must start in next word.
AMS Frame Body	See comments	First 16-bit word not tested Second 16-bit word must be b'0100 0000 0000 xx00' where xx represents the MDC geographical address to boot. Remainder of AMSFrameBody field contains post boot instructions and is not tested.
CheckWord		Not tested.

Figure 62 Boot Command Fields Checked

13.1.16 Set Heaters

Enable or disable the heaters independently from the power state.

TBP.

13.2 PDL Defined External Commands

The following table defines the commands defined with the AMS-02 Program Data Library (PDL) database. Each PDL command contains a single AMSBlock from the externally defined set.

CCN	Mnemonic	AMSBlock	Parameter
AMS001	AMS_STARTUP	Section 13.1.1	N/A
AMS002	AMS_SHUTDOWN	Section 13.1.2	N/A
AMS003	AMS_STANDBY	Section 13.1.3	N/A
AMS004	AMS_MAGWDT	Section 13.1.4	Timer in seconds
AMS005	AMS_PWRSTATE	Section 13.1.5	Power state SC
AMS006	AMS_OPSSTATE	Section 13.1.6	Operations state SC
AMS007	AMS_COMSTATE	Section 13.1.7	Telemetry state SC
AMS012	AMS_PARM1	Section 13.1.9	Hex parameter
AMS013	AMS_PARM2	Section 13.1.10	Hex parameter
AMS014	AMS_PARM3	Section 13.1.11	Hex parameter
AMS015	AMS_PARM4	Section 13.1.12	Hex parameter
AMS016	AMS_PARM5	Section 13.1.13	Hex parameter
AMS017	AMS_PING	Section 13.1.14	Node address

13.3 PDL Defined Standard POCC Command

AMS-02 has a single “standard command” for use by the AMS-02 POCC. This command consists of a CCSDS packet containing an AMS Frame of AMS Blocks. The contents of this command are not defined to external organizations.

This command does not have the EXTCMD bit set in the AMSFrame header.

13.4 Command Framing

Notes:

1. Commands must be at least 13 AMS-defined 16-bit words PLUS 8 16-bit CCSDS header words PLUS 3 16-bit required overhead words. The 3 overhead words are one spare word, one Legal Station Mode word, and one checksum word. This makes for a total of (at least) 24 words, which is required by S-band.
2. Commands issued at locations other than the AMS-02 POCC will have the EXTCMD bit (0x2000) set in the AMS Frame header word. These commands will not span command frames.

13.4.1 PLMDM Issues

13.4.2 OIU Issues

13.4.3 HRDL Issues

14 ACOP Master Control Task (MCT)

The ACOP Master Control Task functions as a scheduler for AMSBlock submission. MCT maintains a list of AMSBlocks and details about their requested submissions. This list is persistent across ACOP reboots.

14.1 ACOP MCT AMSBlock Interface Secondary Header

TBP.

	15	14	13	12	11	10	9	8	7	6	5	4	3	2	1	0
1	ListTag															
2	DelayTime															
3	Period															
5	Count															
6	StreamId															
7	BlockType															
8	NodeAddress															
9	DataTypeMajor															
10	DataType															
11	DataCount															
12	Data[0]															

ListTag	"Name of entry". A requests that matches a previous requests ListTag replaces (or deletes) the older request.	
DelayTime	Time till first execution (in 1/100 secs)	
Period	Time period between executions (1/100 secs)	
Count	Number of times to execute	
	0x0000	Delete entry
	0x0001 - 0xFFFC	Repeat count - delete when done
	0xFFFD	Single shot but save to param file
	0xFFFE	Exhausted single shot (occurs next parm file read)
0xFFFF	forever	
StreamID	Stream handle for the reply	
BlockType	AMSBlock BlockType	
NodeAddress	AMSBlock NodeAddress	
DataTypeMajor	Upper nibble of DataType - AAL	
DataType	AMSBlock DataType	
DataCount	AMSBlock DataCount (bytes)	
Data[0]	AMSBlock Data area	

15 AMS-02 Activation – Power Steps

These are Mike's notes on power activation from an email on 1-Mar-04.

Items 0.0 to 2.1 happen sequentially

PAD: I think only 0.0 to 0.4 happen sequentially. After this power states are purely to placate "management".

0.0 Power applied to AMS from any one of
{ISS/UMA A or B or A&B, ISS/PVGF A or B or A&B, STS/APCU B, STS/T0 A}

0.1 When <T(PDS) OK(thermostat in PDS)>, PDS enables power to
Thermostatically controlled 120V heaters (qty=12 pair), A or B or A&B,
JPD Nominal & Redundant (labeled A & B in J documentation, N & R here)
28V feeds

0.2 When <T(JPD+J+JT) OK(Thermostat on JPD)>, JPD powers
JPD N & R,
J (2*JMDC N + 2* JMDC R + JxIF N or R),
JT (2*JINJ + JLV1 + JTBX/2) * (N,R)

0.3 When <JPD N or R powered>
(*Part of*) Global Temperature Sensor Net (GTSN) readout starts in JPD,
? but not needed until MCT starts ?

PAD: Each JMDC that successful starts should be waiting in it's boot prom (execute in place - XIP) code at this point (because the POWER_ON_DETECT flip flop is set) . It waits there until it receives the "go [filename]" command to load (into RAM) and run the GDAQ program. It has always been my contention (not generally accepted) that we should be able to command (ground or ACOP) arbitrary AMSBlocks from this boot prom state, including onto the CAN bus (read temps and throw switches), modify boot prom configuration parameters ("Set Owners" assigning ownership 1553 and HRDL (allowing boot prom to support these interfaces)), and in particular file transfer (upload new GDAQ and/or GDAQ parameter file) ... I do not think that the boot prom has a MCT - it only responds to commands.

0.4 When <Commands received by a JMDC>
Monitor and Control Task (MCT) started on a JMDC (*not before?*)
MCT receives GTSN data,
Other JMDC may be powered down,
JPD N or R feed may be disabled at PDS,
Unused JINJ and JLV1+JTBX/2 maybe powered down at JPD.

PAD: When the "go" command is sent JMDC boot prom loads a more general purpose program - typically GDAQ (but perhaps some diagnostics test program). GDAQ at least would have a MCT that might include GTSN polling (based on parameter file contents). GDAQ parameter file might include pre-sets for various switches (turning off other MDCs and unused JINJ, ...).

1.0 THIS IS DEFINED AS POWER STEP 1.

1.1 When <T(CAB) OK(GTSN, MCT)>

MCT commands PDS to disable CAB heaters?,

MCT commands PDS to enable CAB N, R or N & R (*tbd*) 28V feeds.

2.0 THIS IS DEFINED AS POWER STEP 2.

2.1 When <CAB OK>

MCT commands CAB to reset ramp down timer (!).

PAD: Think TimeLiner. I dont think MCT should reset WDT. In principal it should only be reset by external (but perhaps onboard) command!

Items 2.2A-2.2D can happen in parallel

PAD: Seems like MCT should have an operations state machine to implement from here on down.

2.2A When <T(CCEB) OK(GTSN, MCT)>

MCT does NOT command PDS to disable Cryocooler & Zenith Heaters,

MCT commands PDS to enable CCEB A or B or A&B (*tbd*) 120V feeds,

CCEB reads out Mag Field sensors, data to MCT

Part of GTSN readout via CCEB to MCT (tbd)

For <I=0, 3>

When <T(Cryocooler-I, Zenith-I, Loop-I?) OK(CCEB)>

CCEB starts Cryocooler-I.

When <Cryocooler-I started (CCEB, MCT)>

MCT commands PDS to disable Cryocooler+Zenith Heaters -I.

2.2B When <T(MPD+M) OK(GTSN, MCT)>

MCT commands PDS to enable MPD N or R (*tbd*) 28V feed.

MPD+M power up AST, GPS,

Part of GTSN readout via M to MCT (tbd)

If MPD+M not doing anything useful, activation could be delayed...

2.2C When <T(TTPD+TT) OK(GTSN, MCT)>

MCT commands PDS to enable TTPD N or R (*tbd*) 28V feed.

TTPD+TT readout temp of primary, secondary TTCB, TT loops, radiators, etc.

MCT commands TT to start TTCS either -P or -S.

When <T(TT stuff -P or -S) OK(TT)>

TT starts TTCS-P or -S, per command.

No part of GTSN readout via TT to MCT.

TT activation needed before T activation.

2.2D When <T(UGPD+UG) OK(GTSN, MCT)>

MCT commands PDS to enable UGPD N or R (*tbd*) 28V feed.

UGPD+UG -N or -R starts monitor and control of UGBS, UGBC, UGB-Manifolds, etc.

*UG activation required before U activation (tbc)?
UG 120V heaters (valves, tanks) independent of UG activation, thermostat only.*

3.0 THIS IS POWER STEP 3.

3.1 When <T(Wake-Rad, Ram-Rad) OK(GSTN, MCT)>
MCT commands PDS to disable as many heaters as possible.

Items 3.2A-3.2D can happen in parallel

3.2A For <I=0, 1> *Can also be in parallel*
When <T(ERPD-I, E-I, R-I, EHV-I.(0-2), RHV-I.(0-1), ECal-I, RICH-I)
all OK(GSTN, MCT)>
MCT commands PDS to enable ERPD-I N or R (*tbd*) 28V feed
ERPD-I+E-I+EHV-I.(0-2) activates corresponding electronics,
inc HV
ERPD-I+R-I+RHV-I.(0-1) activates corresponding electronics,
inc HV

3.2B For <I=0, 4> *Can also be in parallel*
When <T(SPD-I, S-I, SHV-I., ToF&ACC-I) all OK(GSTN, MCT)>
MCT commands PDS to enable SPD-I N or R (*tbd*) 28V feed
SPD-I+S-I+SHV-I activates corresponding electronics, inc HV

3.2C When <TT OK(TT, MCT)>
For <I=0, 7> *Can also be in parallel*
When <T(TPD-I+T-I) OK(GSTN, MCT)>
MCT commands PDS to enable TPD-I 28V feed
TPD-I+T-I activates corresponding 24 ladders within tracker.

3.2D When <UG OK(UG, MCT) and T(TRD) OK(GSTN? or UG? or Analysis,
MCT)>
For <I=0, 1> *Can also be in parallel*
When <T(UPD-I+U-I) OK(GSTN, MCT)>
MCT commands PDS to enable UPD-I 28V feed
UPD-I+U-I activates corresponding electronics on TRD

3.3 Data Taking starts automatically.

4.0 THIS IS POWER STEP 4.

PAD: Might be prudent to make this a "separate program" from GDAQ.

Charging the magnet.

POWER STEP 2 re-established

PDS, JPD+J+JT (min set), CAB N & R (repeat N & R) enabled.

CCEB and cryocoolers left ON.

E, R, M?, S, TT, T, U, UG turned off.

Most 120V heaters disabled (ER and TRD Gas heaters may be left enabled).

CAB commanded to ramp to current, starts to draw 120V.
THIS IS POWER STEP 2A.
While CAB ramps to current, AMS total power consumption rises.
When total power consumption passes X,
 all heaters disabled, inc ER and TRD Gas
 cryocoolers tuned off, but CCEB active to measure mag field.
When ramp finished, power consumption drops.
Proceed through power steps 3 and 4 to re-establish data-taking.

No further info on POWER STEPS 3A, 4A.

16 Magnet Charging Operations

This section will address any unique command and data handling requirements of the magnet charging operations.

17 File Transfer Protocol

The following details the file transfer protocol for AMS-02 and ACOP. In this protocol a master (either the ground systems or ACOP) requests that a slave (a JMDC or ACOP) cooperate in transferring a file.

To move files to nodes other than a JMDC or ACOP the file is first uploaded to a JMDC or ACOP and a file copy to the final destination is requested. The protocol of this copy is not addressed here.

This protocol defines several AMSBlocks and their replies that the master writes and reads in a particular order. First we will introduce the AMSBlocks used for the transfer and later the semantics of their use.

17.1 File System Structure and Symbolic File Names

The AMS-02 file structure is flat (there are no sub-directories). Each file has a symbolic name consisting of up to 12 ASCII printable characters. Symbolic file names are terminated by a byte of zero. The transfer protocol does not assume any particular file system structure or features.

17.2 AMSBlock - File Transfer Start

This AMSBlock is sent by the master to start a file transfer. The slave uses the information to prepare for the coming file transfer. This AMSBlock is sent from the master as a request to write then read (an AMS “put” operation). The data formats for write and reply are not symmetrical.

The status of uplink file transfer are checked pointed from time to time in persistent storage allowing uplink file transfers to recover over JDMC and ACOP reboots.

If a slave has an active file transfer the TransferHandle is used to determine if the master is attempting to recover this transfer or poll the transfer’s status. If the two TransferHandles match, the transfer status is just being polled. If they do not match, the existing transfer is aborted and a new transfer is started.

If there is no active transfer the slave examines the last transfer checkpoint to see if it matches. If so the check pointed transfer is recovered.

An uplink File Transfer Start with a zero length deletes any existing check point.

17.2.1 Write Operation Format

On the AMSBlock write²³ operation for this AMSBlock this is the format required.

	15	14	13	12	11	10	9	8	7	6	5	4	3	2	1	0
0	S	E	A	C	O	B	U	R								
1	TransferHandle															
2	FileSize (bytes)															

²³ This is a write operation to the AMSBlock (AKA “put”) – not a file write.

	15	14	13	12	11	10	9	8	7	6	5	4	3	2	1	0
3																
4	SectorSize (bytes)															
5	CRC32 or MD5															
6																
7																
8																
9																
10																
11																
12																
13	ReplyStream															
14	SectorDelay or StatusWindow															
15	Address or Name															
//																//
N																

The option bits in the word 0:

Option	If One	If Zero
S	Save the file (you can assume this bit is set).	Do not save the file
E	Execute the file after transfer by jumping to the first address of the transfer. (XIP?)	Do not execute the file (You can assume this is zero.)
A	The final field of this AMSBlock is a memory address to which the file should be written (or read).	The final field of this AMSBlock is a symbolic file name. (You can assume this is zero.)
C	CRC is used as error detection	MD5 is used as error detection. (You can assume this is zero.)
O	Each sector AMSBlock will contain an offset value	The offset value is omitted.
B	The sector offset value is expressed in bytes	The sector offset value is in sectors
U	Uplink request	Downlink request
R	Reset. Abort any active transfer and go to done state.	Normal request

TransferHandle	An integer provided by the master identifying this particular file transfer. The slave uses this value to determine if the master is recovering an existing transfer or requesting a new one. This value is returned in all status replies for this transfer.
SectorSize	The number of bytes in each sector transferred by the protocol. This number may not be larger than 4096.
FileSize	The uplink file size in bytes. For downlink transfers this is do not care.

CRC32 or MD5	For uplink files this is the error detection value computed for the entire file. This must match the value computed when the transfer is complete or the transfer is rejected. For downlink transfers this is do not care.
ReplyStream	This is a handle representing an APID stream to which replies resulting from this transfer will be directed. See “Stream Handle” in section 3.4.
SectorDelay	For downlink requests only this is the number of milliseconds to delay between each sector transmission. Used to control bandwidth loading during downlinks.
StatusWindow	For uplink requests this is the number of sectors between the longer format of status reply. This longer format contains the received sector map.
Address or Name	If option A above is one this value is a symbolic constant (ASCII - decimal or hex) will be converted to a 32-bit binary address to which the transfer will start within the CPU's memory space. This may be FLASH or RAM memory. If option A is a zero then this area contains a symbolic file name. This field is required to be nil terminated.

17.2.2 Read Operation Reply Format

When the AMSBlock is read (get) this is the format of the reply returned. This can be read at any time to determine the current state of a transfer. If no transfer is active, and the TransferHandle matches, the check point copy is returned.

	15	14	13	12	11	10	9	8	7	6	5	4	3	2	1	0
0	Status															
1	TransferHandle															
2	CRC32 / MD5 or ReceivedSectorMap															
3																
4																
5																
6																
7																
8																
9																

TransferHandle	The integer provided by the master identifying this particular file transfer.
Status	0x00 – Done 0x01 – Reading 0x02 – Writing 0xAA – Abort 0xEE – Error
CRC32 / MD5 or ReceivedSectorMap	For downlink files this is the error detection value computed for the entire file. This must match the value computed when the transfer is complete or the transfer is rejected.

	For uplink files this is the current map of sectors that have been received correctly. Note: this is not limited to the shown 8 words length.
--	---

17.3 AMSBlock - File Sector

During the protocol files are moved as sectors. For uplink operations each sector for the file is sent as a request to write and then read. The sectors need not be sent in order and may be repeated as desired by the master.

For downlink operations the transfer mechanism simply creates a series of replies (much like the Master Control Task does for housekeeping data).

17.3.1 Write Operation Format

It is only valid for the master to write sectors during an uplink. This is the format used.

	15	14	13	12	11	10	9	8	7	6	5	4	3	2	1	0
0	R	R	R	R	O	B	U	R								
1	TransferHandle															
2	SectorOffset															
3																
4	SectorData															
//																//
N	CRC16															

Option	If One	If Zero
O	This sector AMSBlock contains an offset value	The offset value is omitted
B	The sector offset value is expressed in bytes	The sector offset value is in sectors
U	Uplink request – must be 1	This is a downlink sector
R	Available for use	Available for use

TransferHandle	The integer provided by the master identifying this particular file transfer.
SectorOffset	The offset from the start of file in sectors or bytes. If “O” above is 1 this is omitted.
SectorData	The data to be written at this sector or address. For the final AMSBlock this data may be less than a full sector. The actual length is determined by the AMSBlock length.
CRC16	Each AMSBlock containing a sector is protected by a CRC16 check value.

17.3.2 Read Operation Reply

During an uplink operation this is the reply the format of the reply.

	15	14	13	12	11	10	9	8	7	6	5	4	3	2	1	0
0	Status															
1	TransferHandle															
2	ReceivedSectorMap															
//																//
N																

TransferHandle	The integer provided by the master identifying this particular file transfer.
Status	0x00 – Done 0x01 – Reading 0x02 – Writing 0xAA – Abort 0xEE - Error
ReceivedSectorMap	This is a bit map representing which sectors have been successfully received. The first bit indicates sector zero condition.

The ReceivedSectorMap is only included in this reply on every nth read as determined by StatusWindow above and when the ReceivedSectorMap indicates that all sectors have successfully transferred.

17.4 Downlink Reply Format

When the master has requested a downlink of a file the file transfer mechanism simply creates a series of AMSBlock replies, one for each file sector. This process uses SectorDelay to limit the bandwidth impact of the transfer. The format used for these “replies” is the same as Section 17.3.1 with the exception that the U flag is zero indicating a downlink.

17.5 File Transfer Protocol Semantics

The master can use a read request of the Start File Transfer AMSBlock at any time to poll the status of an active transfer. (A read then write request with the same TransferHandle can be used as well.)

Note: At this time it is not envisioned to support multiple file transfers at the same time. If this becomes required the TransferHandle can be used to sort things out.

17.5.1 Uplink of Files

The design of this protocol is particularly optimized to uplink files over the nominal command and housekeeping links for AMS-02. The communications on this link are not symmetrical. Commands go up via S-Band and replies come down via KU-Band. These have physically different coverage and are operated differently by NASA.

It will not be uncommon to see 10 or 15 minutes pass between issuing a command and seeing its reply (as the replies sit in the communications outage recorder). During at least some of this time there will may be significant commanding access which can be utilized to provide uplink bandwidth.

To accommodate operation over these links the protocol is design to reduce the need for the master to wait on status replies. Transfers can continue and when replies eventually arrive they can be used to recover errors.

For uplink of files the master creates a write and then read request of the AMSBlock File Transfer Start (Section 17.1). This can specify a new or existing symbolic file name or any memory address (for RAM loads or direct FLASH writes). This AMSBlock will be replied to indicating the status of the request (per Section 17.2.2). This reply will contain a ReceivedSectorMap. This map may have some bits set if an existing transfer is being recovered. The master need not wait for this reply. It can assume it will succeed and begin the file transfer. If the success assumption eventually proves wrong it can abort the transfer.

The master simply continues the transmission of sectors of data paced only by the speed limits imposed by the communications media²⁴. The master may monitor the results of the transfer using the replies of AMSBlock File Sector (Section 0). Every nth such reply (controlled by StatusWindow) will contain the map of correctly received and recorded sectors. This map can be used to determine any sectors lost or corrupted. The master is free to retransmit any sector at any time – the slave must treat all accesses as random²⁵.

The slave writes each sector as it is received to the appropriate location. If the sector is correctly written the bit representing this sector in the ReceivedSectorMap is set to one. If this uplink will result in the over writing of an existing symbolic file name the sectors are written as if to a new file (the old copy is available until the transfer completes successfully).

Periodically the slave records all information about an active uplink to FLASH memory. When a File Transfer Start is received, and no uplink is active, the new request's TransferHandle is compared with the stored copy. If these match the slave recovers the in progress transfer. Similar recovery is performed by the slave if a File Sector AMSBlock is received with no active transfer and its TransferHandle matches the current checkpoint.

When the slave determines the transfer is done (by determining all bits are set in the ReceivedSectorMap), the reply always includes the ReceivedSectorMap. At this point the slave enters the file into the symbolic file directory if appropriate, replacing

²⁴ The speed of the protocol does not imply any limits, however the ISS commanding systems have practical limits of one command per second. Ground software supporting file transfers should have the ability to pace the creation of commands to within suitable limits expressed in commands per minute.

²⁵ This has ramifications of read before write when the sector size for the transfer does not match the FLASH sector size.

any file with a matching name. The check point copy for the transfer is updated, indicating a successfully completed transfer. If the execution bit is set the slave delays 10 seconds (in hope that the final status reply may be received by the master) and then begins the execution.

The master determines the transfer is done when it receives a ReceivedSectorMap indicating all sectors received. If this status is lost, for instance due to the execution of an uploaded file, the master can poll the last transfer status and receive the checkpoint copy.

17.5.2 Downlink of Files

For downlink of files the master simply creates a write then read request of the AMSBlock File Transfer Start (Section 17.1). This can specify an existing symbolic file name or any memory address (for core dumps). This AMSBlock will be replied to indicating the status of the request (per Section 17.2.2). This reply will contain an error correction code for the entire file.

If the request is accepted the master will observe a series of AMSBlock File Sectors (Section 17.4) having the TransferHandle that was specified in the File Transfer Start request. These replies will be in the stream specified by ReplyStream²⁶. These sectors should be checked for validity using the CRC16 attached and, if correct, used to construct the file. When a File Sector is received with the status indicating the transfer is done the master should use the whole file error correction code to verify the transfer was received correctly.

If an error is detected in any sector CRC16, in the sequencing of the sectors, or the whole file error code the file transfer has failed. There is no error recovery for downlink files.

Error recovery is done by simply creating a new request for the same file with a new TransferHandle. This request aborts any active transfer and starts the new transfer.

17.6 Transfer Timeouts

Both uplink and downlink masters should provide for timing of transfers. This timeouts should be reset by the nominal traffic produced by the transfers. In the event of a timeout the master can poll the slave to determine the slaves transfer status.

17.7 AMSBlock File Systems Operations

Requests to this AMSBlock result in file systems operations.

17.7.1 Write Operation Request

This write is rejected with an error report if an operation is already active.

	15	14	13	12	11	10	9	8	7	6	5	4	3	2	1	0
0	Operation															
1	TransferHandle															

²⁶ This StreamHandle for instance can identify AMSHK, AMSHKH, or PTOPREPLY

2	Argument(s)	
//		//
N		

Operations	Op Code	Description
	0	Directory listing. If arguments exist they are file names for which a listing is desired. If no arguments - list all files.
	1	Delete files. For each file named in the arguments delete the file.
	2	Rename file. Requires exactly two arguments. The first names an existing file. The second provides a new symbolic name.
	3	Copy file. Requires exactly two arguments. The first names an existing file. The second provides symbolic name to copy this file into. This may over write a file.
	4	Create a link to a file. Requires exactly two arguments. The first names an existing file. The second provides a symbolic name that is to be linked to the same file. This will delete any file with the same name as the symbolic link.
	5	Transfer file to another JMDC or to ACOP. Act as a master to transfer the file specified in the first argument to the slave specified in the second argument.
	6	Transfer file to another node. Using internal protocols transfer this file to another node over either AMSWire or CAN bus. The first argument is the file name and the second is the node address as a decimal or hex (leading 0x0) string.
	7	Execute file. Load this file into RAM and transfer control to this file. This replaces any currently loaded program. This accepts a single argument which is available to the newly loaded program. (How TBD).
	0xFF	Reformat the file system deleting all files. Requires one argument. This argument must be an integer value of seconds within plus or minus 60 seconds of the current 1553 broadcast time sync value.
TransferHandle	The integer provided by the master identifying this request.	
Argument(s)	These are argument strings. All but the last argument must be nil (zero) terminated.	

17.7.2 Read Operation Reply

All replies to file operations are symbolic ASCII listings. The AMSBlock can be read during operations to determine the operational status. If the last operation has been completed its status report is returned.

	15	14	13	12	11	10	9	8	7	6	5	4	3	2	1	0
0	Operation															
1									TransferHandle							
2									ASCIIReport							
//																//
N																

Operation	The operation
TransferHandle	The integer provided by the master identifying this request.
ASCIIReport	An ASCII formatted report with nil (zero) termination. This report should be as short and simple as possible using tabs and new lines to conserve space. It should be designed to be readily parsed.

18 Critical Health Data

18.1 Background

AMS-02 has formally requested 10 bytes per second of payload safety data to be called Critical Health Data (CHD). As of this writing this request is still under review by the ISS program. This section provides details of the implementation of this system.

18.2 Introduction

The AMS-02 system will generate housekeeping data in a cyclic fashion for transmission to the AMS-02 Payload Operations Control Center (POCC). The housekeeping stream will consist of various AMSBlocks each collected on its own schedule (based on the volatility and criticality of the data within the particular AMSBlock) as well as various AMSBlocks that are replies to ad hoc ground commanding.

This data is organized by AMS-02 as a stream of CCSDS blocks called AMSFrames. Except for headers the contents of this data stream is completely dynamic, subject to changing schedules for collecting the AMSBlocks and ground commanding loads. The size of these AMSFrames is limited by design to not more than 2560 bytes.

The AMSFrames are read by the ISS Payload Multiplexer/Demultiplexer (PLMDM – our 1553 bus controller) once per second as a series of 1553 remote terminal reads. The PLMDM then incorporates the contents of this AMSFrame (the payload of the CCSDS packet) into the PLMDM Current Value Table (CVT) which is the collection of the health and status data for all payloads.

The PLMDM transmits the CVT periodically via the High Rate Data Link (HRDL) to the High rate Communications Outage Recorder (HCOR). HCOR is used to buffer downlink data during lose of signal (LOS) conditions²⁷ (10 to 20 minutes of each 90 minute orbit). During signal acquired sessions the HCOR presents the health and status data to the High Rate Frame Multiplexer (HRFM) for inclusion in the KU-band downlink stream. This data is de-framed and the AMS-02 POCC is presented our housekeeping data during the Acquisition Of Signal (AOS) session. Effectively during nominal operations the AMS-02 POCC will see an entire orbit's worth of housekeeping data compressed into the AOS time for the KU-TDRS system.

In addition to transmitting the CVT to the KU system the PLMDM provides input to the Command and Control (C&C) MDM. The C&C MDM provides the logical equivalent services to ISS system components as the PLMDM provides to payloads. It is the safety critical system that operates the ISS infrastructure systems. The PLMDM Operational Status Data Table (OSDT) allows the definition of areas within a payloads 1553 H&S transmission that are to be forwarded by the PLMDM to the C&C MDM as “payload safety data”. The payload safety data is incorporated into the

²⁷ The ISS KU system links data via one of two active (there is one spare) Tracking Data Relay Satellites (TDRS). The KU system is line of site and as the ISS orbits it loses and acquires signaling ability.

ISS infrastructures H&S dataset and is transmitted via the ISS S-Band systems. The S-band radio system is considerably more robust and offers extended coverage over the KU-band systems.

18.3 CHD Format

The Critical Health Data consists of ten bytes. During ISS operations this data shall be present in the 1553 data presented to the PLMDM as house keeping data. The frame status byte AMSSHF will indicate its existence in the frame. When Critical Health Data is present the AMS Block data starts ten bytes later in the frame.

Most of the format of the CHD is defined to accommodate the display of the data on the NASA POIC, HOSC, and SSCC display systems. This should allow a common nomenclature to exist between AMS-02 and NASA. In the table below the “Field Mnemonic” and “State Code” values should be displayed on NASA screens. The NASA PDL convention of byte numbers starting at 1 and bit numbers starting at 0 has unfortunately been preserved.

Note: The following definition of CHD will serve to support early testing of the system design. As operational knowledge is gained the CHD will be tuned to better support the system operation.

	0	1	2	3	4	5	6	7	
1	HEARTBEAT								1
2	CMD_COUNT								2
3	POWERSTEP			BUS_A	BUS_B	WATTS			3
4	MAGNET_STATE			UPS_A	UPS_B	CRYO_COOLER			4
5	MCT_OWNER		HRDL_OWNER		LRDL_OWNER		DAQ_OWNER		5
6	VEHICLE	HRDL_ACTIVE	LRDL_ACTIVE	DAQ_ACTIVE	DAQ_BUFFER			TAXI_ERRORS	6
7	TEMP_O_ALARM		TEMP_O_WARN		TEMP_U_ALARM		TEMP_U_WARN		7
8	TRD_GAS				MAG_GAS				8
9	TDM								9
10									0
	0	1	2	3	4	5	6	7	

Figure 63 CHD Layout

Byte #	Start Bit #	# Bits	Field Mnemonic	Comments	Values		
1	0	8	HEARTBEAT	Rolling count of HK frames to this stream.	0-255		
2	0	8	CMD_COUNT	Rolling count of valid command frames received from all sources (ground, ACOP, ...)	0-255		
3	0	3	POWERSTEP	AMS-02 Power step on a best guess estimation by looking at PDB switches	Value	State Code	Comment
					0	UNDEF	In transition
					1	STEP-1	
					2	STEP-2	
					3	STEP-3	
					4	STEP-4	
					5	STEP-2A	Magnet charging
					6	STEP-3A	Tracker thermal
3	3	1	BUS_A	ISS Power feed A state	Value	State Code	Comment
					0	OFF	Not powered
3	4	1	BUS_B	ISS Power feed B state	Value	State Code	Comment
					0	OFF	Not powered
3	5	3	WATTS	Watts in 300w granularity	Value	State Code	Comment
					0	300W	0-299 watts
					1	600W	300-599 watts
					2	900W	600-899 watts
					3	1200W	900-1199 watts
					4	1500W	1200-1499 watts
					5	1800W	1500-1799 watts
					6	2100W	1800-2099 watts
4	0	3	MAGNET_STATE		Value	State Code	Comment
					0	NOT_AVAIL	Not available
					1	CHARGING	Charging
					2	RAMPDOWN	
					3	NORMAL	
					4	QUENCH	
					5	0x05	Not assigned
					6	0x06	Not assigned
4	3	1	UPS_A	Status of UPS A (not valid if MAGNET_STATE == NOT_AVAIL)	Value	State Code	Comment
					0	NOK	Battery NOT OK
4	4	1	UPS_B	Status of UPS B (not valid if MAGNET_STATE == NOT_AVAIL)	Value	State Code	Comment
					0	NOK	Battery NOT OK
					1	OK	Battery OK

Byte #	Start Bit #	# Bits	Field Mnemonic	Comments	Values		
					Value	State Code	Comment
4	5	3	CRYO_COOLER	Cryo-cooler status	0	NOT_AVAIL	Status not available
					1	1_FAILED	One unit failed
					2	2_FAILED	Two units failed
					3	3_FAILED	Three units failed
					4	4_FAILED	All units failed
					5	OK	Units OK
					6	0x06	Not assigned
					7	0x07	Not assigned
5	0	2	MCT_OWNER	JMDC that owns the main control computer task	0-3		
5	2	2	HRDL_OWNER	JMDC that owns the HRDL link	0-3		
5	4	2	1553_OWNER	JMDC that owns the 1553 link	0-3		
5	6	2	DAQ_OWNER	JMDC that owns the DAQ task	0-3		
6	0	1	VEHICLE	ISS or STS mode	0	STS	On STS
					1	ISS	On ISS
6	1	1	HRDL_ACTIVE	HRDL (or RS422) transfer active. Indicates Tx light is on.	0	NO	
					1	YES	
6	2	1	LRDL_ACTIVE	LRDL health and status transfer active	0	NO	
					1	YES	
6	3	1	DAQ_ACTIVE	DAQ task is active	0	NO	
					1	YES	
6	4	3	DAQ_BUFFER	Per cent of buffer full	0	NO_DATA	No data
					1	0%	0 to 24%
					2	25%	25 to 49%
					3	50%	50 to 74%
					4	75%	75 to 84%
					5	85%	85 to 94%
					6	95%	95 to less then 100%
					7	FULL	No room left
6	7	1	TAXI_ERRORS	HRDL health flag to detect APS induced errors on HRDL. Used by POIC after APS switching. This value is set on error and cleared once CHD is sent.	1	ERROR	There have been recent errors
					0	NONE	No recent errors
	0	2	TEMP_O_ALARM	Number of sensors in over temp alarm	0	NONE	
					1	1	
					2	2	
					3	3+	Three or more

Byte #	Start Bit #	# Bits	Field Mnemonic	Comments	Values		
					Value	State Code	Comment
7	2	2	TEMP_O_WARN	Number of sensors in over temp warning	0	NONE	
					1	1	
					2	2	
					3	3+	Three or more
7	4	2	TEMP_U_ALARM	Number of sensors in under temp alarm	0	NONE	
					1	1	
					2	2	
					3	3+	Three or more
7	6	2	TEMP_U_WARN	Number of sensors in under temp warning	0	NONE	
					1	1	
					2	2	
					3	3+	Three or more
8	0	4	TRD_GAS	Status of TRD gas systems	0-16		
8	4	4	MAG_GAS	Status of Magnet gases (warm and cold)	0-16		
9	0	16	TDM	See below.	0-65535 – No decom by NASA		

Figure 64 Critical Health Data Format

18.3.1 Time Division Multiplex (TDM) Values

Time division is used to significantly expand the number of data bytes available to AMS for status monitoring in the event of a KU outage (remember – no KU = no H&S data). TDM values are spread out over the HEARTBEAT determined, 256-message cycle (just over 4 minutes).

The TDM values are placed into a table using an indirection table that supports multiple occurrences of any given TDM values per 256-message cycle. This allows more import values to update more often the once per 4 minutes.

The HEARTBEAT value is used to index into the 256-byte entry indirection table and obtain the 16-bit word index of the TDM table defined below.

Notes:

1. Lost or missing health and status packets will result in stale data entries in the TDM table.
2. The TDM tables are not required to be de-multiplexed (de-commutated) by NASA.

The following table just serves as a placeholder until we develop the values we would like to monitor.

Suggested things:

- Last command (bottom 8-bits of DataType from last AMSBlock)
- Event count
- Error counts

- Thermal details
- Gas details
- Gas pressure deltas – Not avail, steady, increasing, decreasing
- USCM status map – active/not (responds on CAN)
- PDB switch map
- JPD switch map
- Crate heater status
- Tracker thermal control details

Word #	Start Bit #	# Bits	Field Mnemonic	Comments	Values
1	0	8	VAL1	First TDM value	0-255
1	8	8	VAL2	Second TDM value	0-255
2	0	16	VAL3	Third TDM value	0-65535

Figure 65 TDM Field Values

18.3.2 TDM Indirection Table

This sample table shows how the two entries above repeat in the data.

HEART BEAT	TDM Word #	HEART BEAT	TDM Word #	HEART BEAT	TDM Word #	HEART BEAT	TDM Word #
0	1	64		128		192	
1	2	65		129		193	
2	1	66		130		194	
3	2	67		131		195	
4		68		132		196	
5		69		133		197	
6		70		134		198	
7		71		135		199	
8		72		136		200	
9		73		137		201	
10		74		138		202	
11		75		139		203	
12		76		140		204	
13		77		141		205	
14		78		142		206	
15		79		143		207	
16		80		144		208	
17		81		145		209	
18		82		146		210	
19		83		147		211	
20		84		148		212	
21		85		149		213	
22		86		150		214	
23		87		151		215	
24		88		152		216	
25		89		153		217	

HEART BEAT	TDM Word #	HEART BEAT	TDM Word #	HEART BEAT	TDM Word #	HEART BEAT	TDM Word #
26		90		154		218	
27		91		155		219	
28		92		156		220	
29		93		157		221	
30		94		158		222	
31		95		159		223	
32		96		160		224	
33		97		161		225	
34		98		162		226	
35		99		163		227	
36		100		164		228	
37		101		165		229	
38		102		166		230	
39		103		167		231	
40		104		168		232	
41		105		169		233	
42		106		170		234	
43		107		171		235	
44		108		172		236	
45		109		173		237	
46		110		174		238	
47		111		175		239	
48		112		176		240	
49		113		177		241	
50		114		178		242	
51		115		179		243	
52		116		180		244	
53		117		181		245	
54		118		182		246	
55		119		183		247	
56		120		184		248	
57		121		185		249	
58		122		186		250	
59		123		187		251	
60		124		188		252	
61		125		189		253	
62		126		190		254	
63		127		191		255	

Figure 66 TDM Indirection Table

19 AMS Block Format

This section discusses the format of AMS Blocks. All AMS-02 data, with the exception of Critical Health Data, is formatted using this mechanism. Note that these are AMS-02 internal formats included here for reference only.

19.1 Block Length

The length field is not considered to be part of the block (non self inclusive). When in serial streams like HRDL, RS422, and 1553 it is placed before the AMS Block. If zero, it signals end-of-data for this frame. This value is a byte count of the bytes in the block following this field (including the AMS Block Header). There are two formats, normal (0-32767 bytes), and extended (0-2,147,483,647 bytes). AMSBlocks are constructed of 16-bit words and this value will nominally be even.

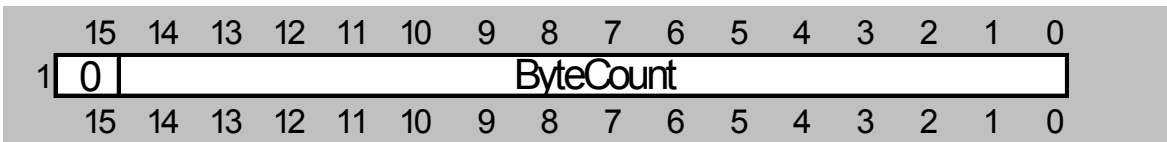

Figure 67 Normal AMS Block Length

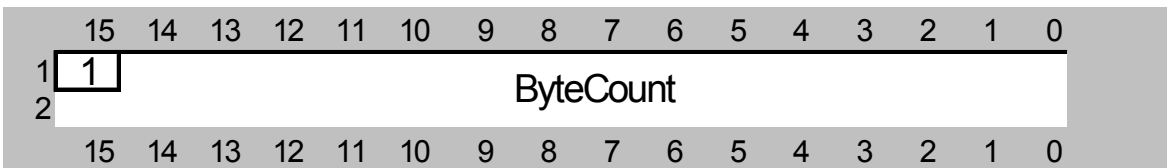

Figure 68 Extended AMS Block Length

19.2 AMS Block Header

Each AMS Block has a header. There are two formats of the AMS Block Header, normal and extended. The normal format supports Data Types between 0x00 and 0x1E.

The extended format supports Data Types between 0x1F0000 and 0x1FFFFFF.

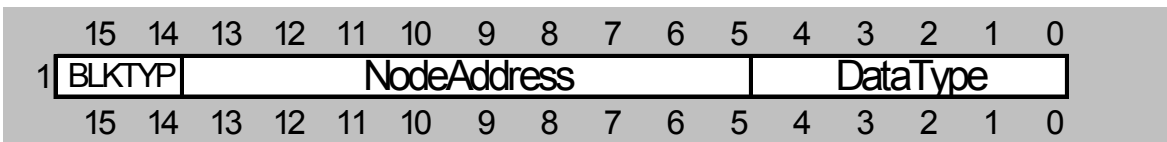

Figure 69 Normal Block Header

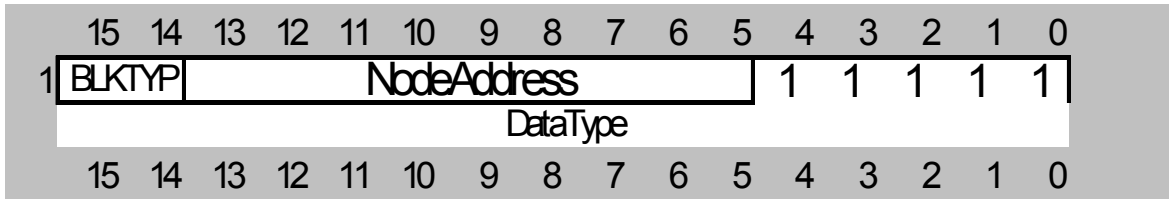

Figure 70 Extended Block Header

19.2.1 AMS Block BLKTYP - Block Type

The following table defines Block Type:

15	14	Block Type
0	X	Request
1	X	Reply
X	0	Write then read
X	1	Write

Figure 71 AMS Block Type

19.2.2 AMS Block NodeAddress

AMS-02 Node Numbers are enumerated in Section 23.

19.2.3 AMS Block DataType

This field defines the contents of the block. Data types are defined according to the needs of a node. There are a few required types. These must be implemented.

DataType can be thought of as just the “symbolic address” of a “remote” variable we want to write to or read from.

DataType 0x0 is not the same as DataType 0x1F0000.

Notes from XC:

Proposed Data Types Arrangement

Data types are classified as the following:

1. Required Data Types (0 - 1)
 2. Common Data Types (30 - 2)
 3. Grouped data types (0x1f0000 - 0x1ffff)
- in format 0x1fggcc, where gg is group ID and cc is command ID in the group

Required Types Defined:

-- 0: Boot command
Reboot the target system. (write only)

-- 1: Echo command

Send data to the target and get the same data back.

Common Types Defined:

-- 0x1c: Test data generate

Send a short command and get back a set of test data generated by the target

-- 0x1d: Test data verify

Send a set of test data to the target and get back only the check result

-- 0x1e: Debug/Test

Free to use for debug and test

Defined Groups:

-- 0x1f01xx: NASA Commands

The commands which we registered to NASA services

-- 0x1f0101: Start-up

-- 0x1f0102: Shutdown

-- 0x1f0103: Standby

-- 0x1f0104: Magnet Watch-dog timer

-- 0x1f0105: Operation Step (Power Step)

-- 0x1f0106: Operation condition

-- 0x1f0107: Telemetry state

-- 0x1f0108: Set owners

-- 0x1f0109: Parameter 1 (reserved)

-- 0x1f010a: Parameter 2 (reserved)

-- 0x1f010b: Parameter 3 (reserved)

-- 0x1f010c: Parameter 4 (reserved)

-- 0x1f010d: Parameter 5 (reserved)

-- 0x1f02xx: JMDC System Task Commands

The commands for JMDC system tasks

-- 0x1f0200: HRDL running status

-- 0x1f0201: LRDL running status

-- 0x1f0202: AMSWire channels status

-- 0x1f0203: CAN channels status

-- 0x1f0204: Task table

-- 0x1f0205: Action to all tasks

-- 0x1f0206: Action to DAQ tasks

-- 0x1f0207: Action to MCT tasks

-- 0x1f0208: Action to one task

-- 0x1f0210: Current tasks in IRQ queue

-- 0x1f0211: Current tasks in Timer Queue

-- 0x1f0212: Current tasks in high priority queue
 -- 0x1f0213: Current tasks in low priority queue

-- 0x1f03xx: Telemetry (HRDL/LRDL) Control
 The commands to control the telemetry operations

-- 0x1f0300: HRDL light off
 -- 0x1f0301: HRDL light on
 -- 0x1f0302: HRDL data out stop
 -- 0x1f0303: HRDL data out start
 -- 0x1f0304: HRDL output schedule
 -- 0x1f0305: HRDL output rate
 -- 0x1f0306: HRDL parameters

-- 0x1f0310: LRDL time synchronize

-- 0x1f04xx: Keyboard/terminal commands
 The commands act as keyboard inputs and terminal outputs

-- 0x1f0400: TTY "printf"

-- 0x1f05xx: File operations
 Commands to handle file transfer, file system operations and flash memory operations

-- 0x1f0500: Start file transfer
 -- 0x1f0501: File sector data
 -- 0x1f0502: File sector status
 -- 0x1f0503: File system operation (from ICD)
 -- 0x1f0504: File operation (from Kounine)
 -- 0x1f0505: Flash operation

-- 0x1f06xx: DAQ commands
 The commands to control DAQ tasks

-- 0x1f0600: Data taking stop
 -- 0x1f0601: Data taking start
 -- 0x1f0602: Event builder status
 -- 0x1f0603: Level-3 status

-- 0x1f07xx: MCT commands
 The commands to control MCT tasks

-- 0x1f0700: Q-List stop
 -- 0x1f0701: Q-List start
 -- 0x1f0702: Current Q-List
 -- 0x1f0703: Add to Q-List
 -- 0x1f0704: Remove from Q-List

-- 0x1f08xx: JMDC debug commands

The commands to debug or check JMDC system

- 0x1f0800: JIM-HRDL/422 device parameters
- 0x1f0801: JIM-HRDL/422 register access
- 0x1f0802: JIM-HRDL/422 memory access

- 0x1f0804: HRDL test frame output off
- 0x1f0805: HRDL test frame output on

- 0x1f0808: JIM-AMSW/1553 device parameters
- 0x1f0809: JIM-AMSW/1553 register access
- 0x1f080a: JIM-AMSW/1553 memory access

- 0x1f080c: JIM-AMSW JINJ port fake events off
- 0x1f080d: JIM-AMSW JINJ port fake event on

- 0x1f0810: 1553 ACE device parameters
- 0x1f0811: 1553 ACE BU-61582 (ISS) register access
- 0x1f0812: 1553 ACE BU-61582 (ISS) memory access
- 0x1f0813: 1553 ACE BU-61580 (STS) register access
- 0x1f0814: 1553 ACE BU-61580 (STS) memory access

- 0x1f0818: JIM-CAN device parameters
- 0x1f0819: JIM-CAN register access
- 0x1f081a: JIM-CAN memory access

- 0x1f081c: JIM-CAN bypass mode off
- 0x1f081d: JIM-CAN bypass mode on

- 0x1f40xx: DDRS2 commands
The commands for DDRS2

- 0x1f41xx: ACOP commands (Rack interface control)
The command for ACOP

- 0x1f42xx: AAL Commands
The command for AAL

19.2.4 Required Data Types

Each node must provide a valid response to the following data types.

Data Type	Name	Length	Comments
1	Ping	Any	Echos back to sender

Figure 72 Data Types Every Node Must Provide

19.2.5 Common Data Types

The following are common data types that can be implemented on any node. These are not required but if the DataType value is used the data must be in the prescribed format.

DataType	Name	Length	Comments
0	Boot	Any	Boots receiving system

Figure 73 Command Data Types Any Node Can Provide

20 AMS Block Framing

The unit of transfer on AMS-02's communications links is an AMSFrame.

This section discusses how AMSBlocks are packed and later extracted from AMSFrames.

20.1 Constructing Frames From AMSBlocks

AMSFrames consist of a CCSDS packet containing an AMSFrame header and AMSBlocks packed together. AMSBlocks need not start at the beginning of an AMSFrame and may span one or more AMSFrames.

The AMSFrame header has a status (see FrameStatus Section 3.3.3) and a link to the start of the first AMSBlock within the AMSFrame (see Link1StBlock Section 3.3.3). The Link1StBlock value is a byte index, relative to the first byte following all headers.

There are two special case values for Link1StBlock. 0xFFE indicates that no AMSBlocks starts within this AMSFrame. This means that this AMSFrame consists of some "middle part" of an AMSBlock that is larger than an AMSFrame. The other special case is -0xFFF indicating that this AMSFrame is a fill frame and can be completely ignored. (Note: for H&S data the CHD will be processed for fill frames..).

An AMSBlock ByteCount of 0x0 can be used to terminate the AMSBlocks within an AMSFrame.

20.2 AMSBlock Secondary Headers

AMSBlocks are framed with a secondary header as follows.

20.2.1 Uplink Requests (Commands)

	15	14	13	12	11	10	9	8	7	6	5	4	3	2	1	0
0	Priority				CommandID											
1	CmdTimeMSB															
2	CmdTimeLSB															

Priority	Who knows.
CommandID	A value identifying this command instance.
CmdTime	The time the command is to be issued. Measured in hummingbird wing beats.

20.2.2 Downlink Relies (Telemetry)

	15	14	13	12	11	10	9	8	7	6	5	4	3	2	1	0
0	DataStatus				CommandID											
1	DataTimeMSB															
2	DataTimeLSB															

DataStatus	<pre> #define ABE_OK 0x00 // Successful completion #define ABE_ABORT 0x01 // Abort: from slave #define ABE_UNKNOWN 0x02 // Abort: unknown types, operations #define ABE_NOSPACE 0x03 // Abort: no space #define ABE_NODEVICE 0x04 // Abort: no device or target #define ABE_NOTSUPPORT 0x05 // Abort: non supported function #define ABE_ERROR 0x08 // Error: from slave #define ABE_COMM 0x09 // Error: communications #define ABE_PROTOCOL 0x0A // Error: protocol #define ABE_FORMAT 0x0B // Error: data format #define ABE_TIMEOUT 0x0C // Error: timeout </pre>
CommandID	The value from the command that caused this reply.
DataTime	The time the data was created. Measured in hummingbird wing beats.

20.3 De-Framing AMSFrames

The process of de-framing AMSFrames from a stream of data into a series of AMSBlocks involves first synchronizing to the start of an AMSBlock. AMSFrames within the stream are examined to find a Link1StBlock value within the current AMSFrame. The AMSBlock currently being processed is set based on Link1StBlock.

While synchronized the AMSBlock ByteCount is examined. If zero, the remainder of this AMSFrame is ignored and processing continues at the first parameter (as though synchronization was lost). If non-zero this value is used to control extraction of the AMSBlock. The minimum of the remaining ByteCount and the number of bytes remaining within the AMSFrame are extracted. If the AMSBlock has been completely extracted it is processed the AMSBlock being processed is advanced to the point after the AMSBlock just extracted. The flow continues at the start of this paragraph.

If the AMSBlock spans into the next AMSFrame this AMSFrames Link1StBlock is examined to be sure it is consistent with the number of bytes remaining for the active AMSBlock. To be consistent the remaining value must equal the Link1StBlock or the remaining value must be larger then the AMSFrame size and Link1StBlock must equal 0xFFE (the next AMSBlock segment completely fills the AMSFrame).

If there is an inconsistency the AMSBlock currently being processed is rejected and the De-Framing re-enters the search for synchronization (first paragraph). If the Link1StBlock indicates a fill frame the frame is ignored and the next frame examined.

Assuming consistantcy of the ByteCount and Link1StBlock is maintained segments of the AMSBlock are extracted (ignoring fill frames) until such time as the AMSBlock has been fully extracted. The AMSBlock is then processed, the current AMSBlock is advanced and the processing continues with the second paragraph (while synchronized).

21 AMS Block Envelop Encapsulation

This section describes the standardized formats of AMSBlocks as encapsulated into other AMSBlocks serving as envelops. Envelops can be transmitted over any AMS interface as the data portion of an encapsulating AMSBlock. There are no particular limitations on the DataSize or DataType for envelops. For ease of illustration, the drawings below are shown as if the data is transmitted within AMSFrames. In general each interface (AMSFrames, AMSWire, AMSCan, ..) prescribes a unique “Envelop Header”.

Notes:

1. An envelop may contain one or more blocks, each of which can be constructed into an AMSBlock.
2. The envelop is terminated by a zero length block or by the encapsulating envelop’s DataSize.
3. Envelops should only contain complete blocks. Envelops that contain a portion of a block (due to inconsistency of the DataSize) should be discarded.
4. The drawings below seem to indicate a 16-bit alignment, this is only for the convenience of drawing. There is no restriction on byte alignment within envelops.

21.1 Envelop Encapsulating An AMSBlock

	15	14	13	12	11	10	9	8	7	6	5	4	3	2	1	0
Envelop Header	See Section 19															
Envelop Block	L	Size of block														
	Size extension if “L” = 1															
	R	W	Node Address										Data Type			
	Data Type Extension if “Data Type” = 0x1F															
	Byte 0 of the block								Byte 1 of the block							
															
Last byte of the block																
Envelop Block	0x0000 Zero length terminates blocks in envelop															

21.2 Envelop Encapsulating An AMSWire Block

	15	14	13	12	11	10	9	8	7	6	5	4	3	2	1	0
Envelop Header	See Section 19															
Envelop block	Most significant 16 bits of AMSWire Block															
	Least Significant 16 bits of AMSWire Block															
	Path Word 0															
															
	Last path word															
0x2E								Data Type								

	Data Type Extension if “Data Type” = 0x1F	
	Byte 0 of the block	Byte 1 of the block
	
		Last byte of the block
Envelop block	0x0000 Zero length terminates blocks	

21.3 Envelop Encapsulating an AMS CAN Block

	15	14	13	12	11	10	9	8	7	6	5	4	3	2	1	0
Envelop Header	See Section 19															
Envelop block	Most significant 16 bits of CAN block size															
	Least significant 16 bits of CAN block size															
	Most significant 16 bits of CAN message ID															
	Least significant 13 bits													Not used		
	Byte 0 of the block								Byte 1 of the block							
															
																Last byte of the block
Envelop block	0x0000 Zero length terminates blocks															

22 AMS-02 Path Addressing

This section describes how paths thru the AMS-02 AMSWire DAQ tree are defined.

To be provided.

23 Node Addresses

This is a tabular presentation of each node address in AMS-02 organized by node type.

23.1 JMDC Addresses

There are both physical and functional node addresses in this table. For instance 0x13 is the functional address for the housekeeping (MCT) task.

Nb.	Hex	What's this is
0	000	JMDC-0 on CAN bus
1	001	JMDC-1 on CAN bus
2	002	JMDC-2 on CAN bus
3	003	JMDC-3 on CAN bus
4	004	JMDC-0 on HRDL/RS422/1553
5	005	JMDC-1 on HRDL/RS422/1553
6	006	JMDC-2 on HRDL/RS422/1553
7	007	JMDC-3 on HRDL/RS422/1553
8	008	JMDC-0 via AMS-Wire
9	009	JMDC-1 via AMS-Wire
10	00A	JMDC-2 via AMS-Wire
11	00B	JMDC-3 via AMS-Wire
12	00C	JMDC-0
13	00D	JMDC-1
14	00E	JMDC-2
15	00F	JMDC-3
16	010	JMDC - HRDL/RS422 Owner (TX allowed)
17	011	JMDC - 1553 Owner (Remote Terminal)
18	012	JMDC - DAQ Owner (Event Builder)
19	013	JMDC - MCT (Q-list Executioner, Tracker Thermal Controller, TRD Gas Controller/Mixer)
20	014	free
21	015	free
22	016	ACOP on HRDL/MRDL/1553
23	017	JMDC Broadcast Address

23.2 Slow Control Addresses

The names are of the form:

<subsystem> [-][{<crate><unit><crate>-<unit>}] - {A|B|P|S} Where:

- A, B - 2 different physical units
- P, S Primary, Secondary

Nominally the primary node is the hot module and the secondary is the cold module. Exceptionally both modules are on.

Nb.	Hex	What's this is
24	018	CAB-A
25	019	CAB-B

Nb.	Hex	What's this is
26	01A	CAB-P
27	01B	CAB-S

Nb.	Hex	What's this is
28	01C	USCM-CCEB-A
29	01D	USCM-CCEB-B
30	01E	USCM-CCEB-P
31	01F	USCM-CCEB-S
32	020	USCM-E-0-A
33	021	USCM-E-0-B
34	022	USCM-E-0-P
35	023	USCM-E-0-S
36	024	USCM-E-1-A
37	025	USCM-E-1-B
38	026	USCM-E-1-P
39	027	USCM-E-1-S
40	028	USCM-JPD-A
41	029	USCM-JPD-B
42	02A	USCM-JPD-P
43	02B	USCM-JPD-S
44	02C	USCM-M-A
45	02D	USCM-M-B
46	02E	USCM-M-P
47	02F	USCM-M-S
48	030	PDB-A
49	031	PDB-B
50	032	PDB-P
51	033	PDB-S
52	034	USCM-R-0-A
53	035	USCM-R-0-B
54	036	USCM-R-0-P
55	037	USCM-R-0-S
56	038	USCM-R-1-A
57	039	USCM-R-1-B
58	03A	USCM-R-1-P
59	03B	USCM-R-1-S
60	03C	USCM-S-0-A
61	03D	USCM-S-0-B
62	03E	USCM-S-0-P
63	03F	USCM-S-0-S
64	040	USCM-S-1-A
65	041	USCM-S-1-B
66	042	USCM-S-1-P
67	043	USCM-S-1-S
68	044	USCM-S-2-A
69	045	USCM-S-2-B
70	046	USCM-S-2-P
71	047	USCM-S-2-S
72	048	USCM-S-3-A
73	049	USCM-S-3-B
74	04A	USCM-S-3-P
75	04B	USCM-S-3-S

Nb.	Hex	What's this is
76	04C	USCM-T-0-A
77	04D	USCM-T-0-B
78	04E	USCM-T-0-P
79	04F	USCM-T-0-S
80	050	USCM-T-1-A
81	051	USCM-T-1-B
82	052	USCM-T-1-P
83	053	USCM-T-1-S
84	054	USCM-T-2-A
85	055	USCM-T-2-B
86	056	USCM-T-2-P
87	057	USCM-T-2-S
88	058	USCM-T-3-A
89	059	USCM-T-3-B
90	05A	USCM-T-3-P
91	05B	USCM-T-3-S
92	05C	USCM-T-4-A
93	05D	USCM-T-4-B
94	05E	USCM-T-4-P
95	05F	USCM-T-4-S
96	060	USCM-T-5-A
97	061	USCM-T-5-B
98	062	USCM-T-5-P
99	063	USCM-T-5-S
100	064	USCM-T-6-A
101	065	USCM-T-6-B
102	066	USCM-T-6-P
103	067	USCM-T-6-S
104	068	USCM-T-7-A
105	069	USCM-T-7-B
106	06A	USCM-T-7-P
107	06B	USCM-T-7-S
108	06C	USCM-TT-A
109	06D	USCM-TT-B
110	06E	USCM-TT-P
111	06F	USCM-TT-S
112	070	USCM-U-0-A
113	071	USCM-U-0-B
114	072	USCM-U-0-P
115	073	USCM-U-0-S
116	074	USCM-U-1-A
117	075	USCM-U-1-B
118	076	USCM-U-1-P
119	077	USCM-U-1-S
120	078	USCM-UG-A
121	079	USCM-UG-B
122	07A	USCM-UG-P
123	07B	USCM-UG-S

Nb.	Hex	What's this is
124	07C	CAB-A
125	07D	CAB-B
126	07E	CAB-P

Nb.	Hex	What's this is
127	07F	CAB-S

23.3 JINJ and Trigger Addresses

0, -1, -2, -3, -A, -B label physical modules

P = Primary

S = Secondary

T = Tertiary

Q = Quaternary (?)

All four JINJ may be on. Both JLV1 may be on!!

Nb.	Hex	What's this is
128	080	JINJ-0
129	081	JINJ-1
130	082	JINJ-2
131	083	JINJ-3
132	084	JINJ-P
133	085	JINJ-S
134	086	JINJ-T
135	087	JINJ-Q
136	088	JLV1-A
137	089	JLV1-B
138	08A	JLV1-P

Nb.	Hex	What's this is
139	08B	JLV1-S
140	08C	ETRG-0-A
141	08D	ETRG-0-B
142	08E	ETRG-0-P
143	08F	ETRG-0-S
144	090	ETRG-1-A
145	091	ETRG-1-B
146	092	ETRG-1-P
147	093	ETRG-1-S
148	094	free
149	095	free

23.4 DAQ Addresses

E = ECAL

R = RICH

T = Tracker

U = TRD

0 -1, -2,... = Crate #

A, -B = redundant halves

P = Primary

S = Secondary

Both JINF halves may be on!

EDR – one hot, one cold (?)

RDR – no redundancy (?)

SDR – both may be on (?)

TDR – no redundancy

UDR – one hot, one cold

no Address for “cold”

Nb.	Hex	What's this is
151	097	JINF-E-0-B

Nb.	Hex	What's this is
152	098	JINF-E-0-P

Nb.	Hex	What's this is
153	099	JINF-E-0-S
154	09A	JINF-E-1-A
155	09B	JINF-E-1-B
156	09C	JINF-E-1-P
157	09D	JINF-E-1-S
158	09E	JINF-R-0-A
159	09F	JINF-R-0-B
160	0A0	JINF-R-0-P
161	0A1	JINF-R-0-S
162	0A2	JINF-R-1-A
163	0A3	JINF-R-1-B
164	0A4	JINF-R-1-P
165	0A5	JINF-R-1-S
166	0A6	JINF-T-0-A
167	0A7	JINF-T-0-B
168	0A8	JINF-T-0-P
169	0A9	JINF-T-0-S
170	0AA	JINF-T-1-A
171	0AB	JINF-T-1-B
172	0AC	JINF-T-1-P
173	0AD	JINF-T-1-S
174	0AE	JINF-T-2-A
175	0AF	JINF-T-2-B
176	0B0	JINF-T-2-P
177	0B1	JINF-T-2-S
178	0B2	JINF-T-3-A
179	0B3	JINF-T-3-B
180	0B4	JINF-T-3-P
181	0B5	JINF-T-3-S
182	0B6	JINF-T-4-A
183	0B7	JINF-T-4-B
184	0B8	JINF-T-4-P
185	0B9	JINF-T-4-S
186	0BA	JINF-T-5-A
187	0BB	JINF-T-5-B
188	0BC	JINF-T-5-P
189	0BD	JINF-T-5-S
190	0BE	JINF-T-6-A
191	0BF	JINF-T-6-B
192	0C0	JINF-T-6-P
193	0C1	JINF-T-6-S
194	0C2	JINF-T-7-A
195	0C3	JINF-T-7-B
196	0C4	JINF-T-7-P
197	0C5	JINF-T-7-S
198	0C6	JINF-U-0-A
199	0C7	JINF-U-0-B
200	0C8	JINF-U-0-P

Nb.	Hex	What's this is
201	0C9	JINF-U-0-S
202	0CA	JINF-U-1-A
203	0CB	JINF-U-1-B
204	0CC	JINF-U-1-P
205	0CD	JINF-U-1-S
206	0CE	EDR-0-0-A
207	0CF	EDR-0-0-B
208	0D0	EDR-0-0-P
209	0D1	EDR-0-1-A
210	0D2	EDR-0-1-B
211	0D3	EDR-0-1-P
212	0D4	EDR-0-2-A
213	0D5	EDR-0-2-B
214	0D6	EDR-0-2-P
215	0D7	EDR-0-3-A
216	0D8	EDR-0-3-B
217	0D9	EDR-0-3-P
218	0DA	EDR-0-4-A
219	0DB	EDR-0-4-B
220	0DC	EDR-0-4-P
221	0DD	EDR-0-5-A
222	0DE	EDR-0-5-B
223	0DF	EDR-0-5-P
224	0E0	EDR-1-0-A
225	0E1	EDR-1-0-B
226	0E2	EDR-1-0-P
227	0E3	EDR-1-1-A
228	0E4	EDR-1-1-B
229	0E5	EDR-1-1-P
230	0E6	EDR-1-2-A
231	0E7	EDR-1-2-B
232	0E8	EDR-1-2-P
233	0E9	EDR-1-3-A
234	0EA	EDR-1-3-B
235	0EB	EDR-1-3-P
236	0EC	EDR-1-4-A
237	0ED	EDR-1-4-B
238	0EE	EDR-1-4-P
239	0EF	EDR-1-5-A
240	0F0	EDR-1-5-B
241	0F1	EDR-1-5-P
242	0F2	RDR-0-0-A
243	0F3	RDR-0-0-B
244	0F4	RDR-0-1-A
245	0F5	RDR-0-1-B
246	0F6	RDR-0-2-A
247	0F7	RDR-0-2-B
248	0F8	RDR-0-3-A

Nb.	Hex	What's this is
249	0F9	RDR-0-3-B
250	0FA	RDR-0-4-A
251	0FB	RDR-0-4-B
252	0FC	RDR-0-5-A
253	0FD	RDR-0-5-B
254	0FE	RDR-1-0-A
255	0FF	RDR-1-0-B
256	100	RDR-1-1-A
257	101	RDR-1-1-B
258	102	RDR-1-2-A
259	103	RDR-1-2-B
260	104	RDR-1-3-A
261	105	RDR-1-3-B
262	106	RDR-1-4-A
263	107	RDR-1-4-B
264	108	RDR-1-5-A
265	109	RDR-1-5-B
266	10A	SDR-0-A
267	10B	SDR-0-B
268	10C	SDR-0-P
269	10D	SDR-0-S
270	10E	SDR-1-A
271	10F	SDR-1-B
272	110	SDR-1-P
273	111	SDR-1-S
274	112	SDR-2-A
275	113	SDR-2-B
276	114	SDR-2-P
277	115	SDR-2-S
278	116	SDR-3-A
279	117	SDR-3-B
280	118	SDR-3-P
281	119	SDR-3-S
282	11A	TDR-0-00-A
283	11B	TDR-0-00-B
284	11C	TDR-0-01-A
285	11D	TDR-0-01-B
286	11E	TDR-0-02-A
287	11F	TDR-0-02-B
288	120	TDR-0-03-A
289	121	TDR-0-03-B
290	122	TDR-0-04-A
291	123	TDR-0-04-B
292	124	TDR-0-05-A
293	125	TDR-0-05-B
294	126	TDR-0-06-A
295	127	TDR-0-06-B
296	128	TDR-0-07-A

Nb.	Hex	What's this is
297	129	TDR-0-07-B
298	12A	TDR-0-08-A
299	12B	TDR-0-08-B
300	12C	TDR-0-09-A
301	12D	TDR-0-09-B
302	12E	TDR-0-10-A
303	12F	TDR-0-10-B
304	130	TDR-0-11-A
305	131	TDR-0-11-B
306	132	TDR-1-00-A
307	133	TDR-1-00-B
308	134	TDR-1-01-A
309	135	TDR-1-01-B
310	136	TDR-1-02-A
311	137	TDR-1-02-B
312	138	TDR-1-03-A
313	139	TDR-1-03-B
314	13A	TDR-1-04-A
315	13B	TDR-1-04-B
316	13C	TDR-1-05-A
317	13D	TDR-1-05-B
318	13E	TDR-1-06-A
319	13F	TDR-1-06-B
320	140	TDR-1-07-A
321	141	TDR-1-07-B
322	142	TDR-1-08-A
323	143	TDR-1-08-B
324	144	TDR-1-09-A
325	145	TDR-1-09-B
326	146	TDR-1-10-A
327	147	TDR-1-10-B
328	148	TDR-1-11-A
329	149	TDR-1-11-B
330	14A	TDR-2-00-A
331	14B	TDR-2-00-B
332	14C	TDR-2-01-A
333	14D	TDR-2-01-B
334	14E	TDR-2-02-A
335	14F	TDR-2-02-B
336	150	TDR-2-03-A
337	151	TDR-2-03-B
338	152	TDR-2-04-A
339	153	TDR-2-04-B
340	154	TDR-2-05-A
341	155	TDR-2-05-B
342	156	TDR-2-06-A
343	157	TDR-2-06-B
344	158	TDR-2-07-A

Nb.	Hex	What's this is
345	159	TDR-2-07-B
346	15A	TDR-2-08-A
347	15B	TDR-2-08-B
348	15C	TDR-2-09-A
349	15D	TDR-2-09-B
350	15E	TDR-2-10-A
351	15F	TDR-2-10-B
352	160	TDR-2-11-A
353	161	TDR-2-11-B
354	162	TDR-3-00-A
355	163	TDR-3-00-B
356	164	TDR-3-01-A
357	165	TDR-3-01-B
358	166	TDR-3-02-A
359	167	TDR-3-02-B
360	168	TDR-3-03-A
361	169	TDR-3-03-B
362	16A	TDR-3-04-A
363	16B	TDR-3-04-B
364	16C	TDR-3-05-A
365	16D	TDR-3-05-B
366	16E	TDR-3-06-A
367	16F	TDR-3-06-B
368	170	TDR-3-07-A
369	171	TDR-3-07-B
370	172	TDR-3-08-A
371	173	TDR-3-08-B
372	174	TDR-3-09-A
373	175	TDR-3-09-B
374	176	TDR-3-10-A
375	177	TDR-3-10-B
376	178	TDR-3-11-A
377	179	TDR-3-11-B
378	17A	TDR-4-00-A
379	17B	TDR-4-00-B
380	17C	TDR-4-01-A
381	17D	TDR-4-01-B
382	17E	TDR-4-02-A
383	17F	TDR-4-02-B
384	180	TDR-4-03-A
385	181	TDR-4-03-B
386	182	TDR-4-04-A
387	183	TDR-4-04-B
388	184	TDR-4-05-A
389	185	TDR-4-05-B
390	186	TDR-4-06-A
391	187	TDR-4-06-B
392	188	TDR-4-07-A

Nb.	Hex	What's this is
393	189	TDR-4-07-B
394	18A	TDR-4-08-A
395	18B	TDR-4-08-B
396	18C	TDR-4-09-A
397	18D	TDR-4-09-B
398	18E	TDR-4-10-A
399	18F	TDR-4-10-B
400	190	TDR-4-11-A
401	191	TDR-4-11-B
402	192	TDR-5-00-A
403	193	TDR-5-00-B
404	194	TDR-5-01-A
405	195	TDR-5-01-B
406	196	TDR-5-02-A
407	197	TDR-5-02-B
408	198	TDR-5-03-A
409	199	TDR-5-03-B
410	19A	TDR-5-04-A
411	19B	TDR-5-04-B
412	19C	TDR-5-05-A
413	19D	TDR-5-05-B
414	19E	TDR-5-06-A
415	19F	TDR-5-06-B
416	1A0	TDR-5-07-A
417	1A1	TDR-5-07-B
418	1A2	TDR-5-08-A
419	1A3	TDR-5-08-B
420	1A4	TDR-5-09-A
421	1A5	TDR-5-09-B
422	1A6	TDR-5-10-A
423	1A7	TDR-5-10-B
424	1A8	TDR-5-11-A
425	1A9	TDR-5-11-B
426	1AA	TDR-6-00-A
427	1AB	TDR-6-00-B
428	1AC	TDR-6-01-A
429	1AD	TDR-6-01-B
430	1AE	TDR-6-02-A
431	1AF	TDR-6-02-B
432	1B0	TDR-6-03-A
433	1B1	TDR-6-03-B
434	1B2	TDR-6-04-A
435	1B3	TDR-6-04-B
436	1B4	TDR-6-05-A
437	1B5	TDR-6-05-B
438	1B6	TDR-6-06-A
439	1B7	TDR-6-06-B
440	1B8	TDR-6-07-A

Nb.	Hex	What's this is
441	1B9	TDR-6-07-B
442	1BA	TDR-6-08-A
443	1BB	TDR-6-08-B
444	1BC	TDR-6-09-A
445	1BD	TDR-6-09-B
446	1BE	TDR-6-10-A
447	1BF	TDR-6-10-B
448	1C0	TDR-6-11-A
449	1C1	TDR-6-11-B
450	1C2	TDR-7-00-A
451	1C3	TDR-7-00-B
452	1C4	TDR-7-01-A
453	1C5	TDR-7-01-B
454	1C6	TDR-7-02-A
455	1C7	TDR-7-02-B
456	1C8	TDR-7-03-A
457	1C9	TDR-7-03-B
458	1CA	TDR-7-04-A
459	1CB	TDR-7-04-B
460	1CC	TDR-7-05-A
461	1CD	TDR-7-05-B
462	1CE	TDR-7-06-A
463	1CF	TDR-7-06-B
464	1D0	TDR-7-07-A
465	1D1	TDR-7-07-B
466	1D2	TDR-7-08-A
467	1D3	TDR-7-08-B
468	1D4	TDR-7-09-A
469	1D5	TDR-7-09-B
470	1D6	TDR-7-10-A
471	1D7	TDR-7-10-B
472	1D8	TDR-7-11-A
473	1D9	TDR-7-11-B
474	1DA	UDR-0-0-A
475	1DB	UDR-0-0-B
476	1DC	UDR-0-0-P
477	1DD	UDR-0-1-A
478	1DE	UDR-0-1-B
479	1DF	UDR-0-1-P
480	1E0	UDR-0-2-A
481	1E1	UDR-0-2-B
482	1E2	UDR-0-2-P
483	1E3	UDR-0-3-A
484	1E4	UDR-0-3-B
485	1E5	UDR-0-3-P
486	1E6	UDR-0-4-A
487	1E7	UDR-0-4-B
488	1E8	UDR-0-4-P

Nb.	Hex	What's this is
489	1E9	UDR-0-5-A
490	1EA	UDR-0-5-B
491	1EB	UDR-0-5-P
492	1EC	UDR-1-0-A
493	1ED	UDR-1-0-B
494	1EE	UDR-1-0-P
495	1EF	UDR-1-1-A
496	1F0	UDR-1-1-B
497	1F1	UDR-1-1-P
498	1F2	UDR-1-2-A
499	1F3	UDR-1-2-B
500	1F4	UDR-1-2-P
501	1F5	UDR-1-3-A
502	1F6	UDR-1-3-B
503	1F7	UDR-1-3-P
504	1F8	UDR-1-4-A
505	1F9	UDR-1-4-B
506	1FA	UDR-1-4-P
507	1FB	UDR-1-5-A
508	1FC	UDR-1-5-B
509	1FD	UDR-1-5-P
510	1FE	free
511	1FF	free

24 Hex Dump Of Command From STEP

The following shows a short dump in hex of four commands sent from STEP to the payload simulator. The “AMS-02” defined part of the longer commands (commands 1, 2, and 4) is underlined and starts with 0x0100, 0x0101, 0x0102 and ends with 0xDEAD 0xBEEF. The third command is a shorter command showing the CheckSum in the middle of the 1553 command pair.

```
1BF7 C006 0079 2C18 F105 9A6A 0800 0000 0000 0000 0000 0100 0101 0102 0103 0104 0105  
0106 0107 0108 0109 010A 0000 0000 0000 0000 0000 0000 0000 0000 0000 0000 0000  
0000 0000 0000 0000 0000 0000 0000 0000 0000 0000 0000 0000 0000 0000 0000 0000  
0000 0000 0000 0000 0000 0000 0000 0000 0000 0000 0000 0000 0000 DEAD BEEF 44D0  
checksum=44D0 -- O.K.  
1BF7 C007 0079 2C18 F108 E36A 0800 0000 0000 0000 0000 0100 0101 0102 0103 0104 0105  
0106 0107 0108 0109 010A 0000 0000 0000 0000 0000 0000 0000 0000 0000 0000 0000  
0000 0000 0000 0000 0000 0000 0000 0000 0000 0000 0000 0000 0000 0000 0000 0000  
0000 0000 0000 0000 0000 0000 0000 0000 0000 0000 0000 0000 0000 DEAD BEEF 8DD4  
checksum=8DD4 -- O.K.  
1BF7 C008 001B 2C18 F10B 796A 0800 0000 0000 0000 0000 000A 0028 000F 0001 0019 8001  
FB03 0000 0000 0000 0000 0000 0000 0000 0000 0000 0000 0000 0000 0000 0000 0000  
0000 0000 0000 0000 0000 0000 0000 0000 0000 0000 0000 0000 0000 0000 0000 0000  
0000 0000 0000 0000 0000 0000 0000 0000 0000 0000 0000 0000 0000 0000 0000 0000  
checksum=FB03 -- O.K.  
1BF7 C009 0079 2C18 F10D AB6A 0800 0000 0000 0000 0000 0100 0101 0102 0103 0104 0105  
0106 0107 0108 0109 010A 0000 0000 0000 0000 0000 0000 0000 0000 0000 0000 0000  
0000 0000 0000 0000 0000 0000 0000 0000 0000 0000 0000 0000 0000 0000 0000 0000  
0000 0000 0000 0000 0000 0000 0000 0000 0000 0000 0000 0000 0000 DEAD BEEF 55DB
```

25 Hex Dump Of OIU Health and Status

* * * * * pfd v1.0: PDI Telemetry Frames Dump * * * * * Page 1

pfd -- PDI frames binary data file = "ams02a.raw".
pfd -- PDI frames text dump file = "ams02a.hxf".

pfd -- There are 13440 bytes in file "ams02a.raw".
pfd -- Dump will begin at first valid frame.
pfd -- Will dump all frames until EOF or max output reached.
pfd -- 0 bytes preceded the first valid frame of data.

Occur 1 of PDI frame 59=3Bh from file "ams02a.raw". Fr size = 160 bytes.

```
Word * 1 2 3 4 5 6 7 8 9 10 11 12 13 14 15 16 17 18 19 20 *
+
0 * C95A 633B 0000 0008 0034 00FF 0000 0000 3BFF AAAA AAAA AAAA AAAA AAAA AAAA AAAA AAAA AAAA AAAA AAAA *
20 * AAAA AAAA AAAA AAAA AAAA AAAA AAAA AAAA AAAA AAAA AAAA AAAA AAAA AAAA AAAA AAAA AAAA AAAA AAAA *
40 * AAAA AAAA AAAA AAAA AAAA AAAA AAAA AAAA AAAA AAAA AAAA AAAA AAAA AAAA AAAA AAAA AAAA AAAA AAAA *
60 * AAAA AAAA AAAA AAAA AAAA AAAA AAAA AAAA AAAA BBBB 8010 8010 FFFF FFFF FFFF FFFF FFFF FFFF FFFF FFFF *
```

Occur 1 of PDI frame 60=3Ch from file "ams02a.raw". Fr size = 160 bytes.

```
Word * 1 2 3 4 5 6 7 8 9 10 11 12 13 14 15 16 17 18 19 20 *
+
0 * C95A 633C 6409 FF08 0005 00FF 0000 0000 3CFF AAAA AAAA AAAA AAAA AAAA AAAA AAAA AAAA AAAA AAAA AAAA *
20 * AAAA AAAA AAAA AAAA AAAA AAAA AAAA AAAA AAAA AAAA AAAA AAAA AAAA AAAA AAAA AAAA AAAA AAAA AAAA *
40 * AAAA AAAA AAAA AAAA AAAA AAAA AAAA AAAA AAAA AAAA AAAA AAAA AAAA AAAA AAAA AAAA AAAA AAAA AAAA *
60 * AAAA AAAA AAAA AAAA AAAA AAAA AAAA AAAA AAAA BBBB 8010 8010 FFFF FFFF FFFF FFFF FFFF FFFF FFFF FFFF *
```

Occur 1 of PDI frame 61=3Dh from file "ams02a.raw". Fr size = 160 bytes.

```
Word * 1 2 3 4 5 6 7 8 9 10 11 12 13 14 15 16 17 18 19 20 *
+
0 * C95A 633D 0000 0000 0000 00FF 0000 0000 3DFF AAAA AAAA AAAA AAAA AAAA AAAA AAAA AAAA AAAA AAAA AAAA *
20 * AAAA AAAA AAAA AAAA AAAA AAAA AAAA AAAA AAAA AAAA AAAA AAAA AAAA AAAA AAAA AAAA AAAA AAAA AAAA *
40 * AAAA AAAA AAAA AAAA AAAA AAAA AAAA AAAA AAAA AAAA AAAA AAAA AAAA AAAA AAAA AAAA AAAA AAAA AAAA *
60 * AAAA AAAA AAAA AAAA AAAA AAAA AAAA AAAA AAAA BBBB 8010 8010 FFFF FFFF FFFF FFFF FFFF FFFF FFFF FFFF *
```

Occur 1 of PDI frame 62=3Eh from file "ams02a.raw". Fr size = 160 bytes.

```
Word * 1 2 3 4 5 6 7 8 9 10 11 12 13 14 15 16 17 18 19 20 *
+
0 * C95A 633E 9701 0100 5206 00FF 0000 0000 3EFF AAAA AAAA AAAA AAAA AAAA AAAA AAAA AAAA AAAA AAAA AAAA *
20 * AAAA AAAA AAAA AAAA AAAA AAAA AAAA AAAA AAAA AAAA AAAA AAAA AAAA AAAA AAAA AAAA AAAA AAAA AAAA *
40 * AAAA AAAA AAAA AAAA AAAA AAAA AAAA AAAA AAAA AAAA AAAA AAAA AAAA AAAA AAAA AAAA AAAA AAAA AAAA *
60 * AAAA AAAA AAAA AAAA AAAA AAAA AAAA AAAA AAAA BBBB 8010 8010 FFFF FFFF FFFF FFFF FFFF FFFF FFFF FFFF *
```

26 Payload Data Library Reports – Commands

The following tables are extractions from reports generated by the Payload Data Library (PDL) system. They represent some of the information about commands defined in PDL.

CCN	Mnemonic	Name	Description	Len	Variable Len	Cmd Type
AMS0001	AMS_STARTUP	STARTUP	PLMDM startup notification.	13	N	P
AMS0002	AMS_SHUTDWN	SHUTDOWN	PLMDM Shutdown notification.	13	N	P
AMS0003	AMS_STANDBY	STANDBY	PLMDM standby notification.	13	N	P
AMS0004	AMS_MAGWDT	MAGNET_WDT	Magnet WDT set	13	N	M
AMS0005	AMS_PWRSTEP	POWER_STATE	Set power state.	13	N	M
AMS0006	AMS_OPSSTATE	OPS_STATE	Set operations state.	13	N	M
AMS0007	AMS_COMSTATE	COMM_STATE	Set telemetry state.	13	N	M
AMS0008	AMS_POCC	POCC	AMSBlocks from POCC	53	N	M
AMS0009	AMS_POCC_V	POCC_VAR	AMSBlocks from POCC - variable sized		Y	M
AMS0010	AMS_GENERIC	GENERIC_HEX	Generic variable length hex		Y	M
AMS0011	AMS_STRING	GENERIC_STR	Genric string	53	N	M
AMS0012	AMS_PARM1	PARAMETER_1	Parameter 1	13	N	M
AMS0013	AMS_PARM2	PARAMETER_2	Parameter 2	13	N	M
AMS0014	AMS_PARM3	PARAMETER_3	Parameter 3	13	N	M
AMS0015	AMS_PARM4	PARAMETER_4	Parameter 4	13	N	M
AMS0016	AMS_PARM5	PARAMETER_5	Parameter 5	13	N	M

Figure 74 PDL Commands

Command	Field	Description	Type	Byte	Bit	Len	Contents
AMS0001 AMS_STARTUP	FRMHDR	Frame hdr	IUNS	1	0	16	2000
	BCOUNT	Byte count	IUNS	2	0	16	0006
	BTNODE	Block hdr	IUNS	3	0	16	82FF
	TYPE	Data type	IUNS	4	0	16	0101
	PARM	Parameter	IUNS	5	0	16	0000
	FRMTRM	Frame term	IUNS	6	0	16	0000
	FILL	Cmd pad	SUND	7	0	14	DEADBEEF
AMS0002 AMS_SHUTDWN	FRMHDR	Frame hdr	IUNS	1	0	16	2000
	BCOUNT	Byte count	IUNS	2	0	16	0006
	BTNODE	Block hdr	IUNS	3	0	16	82FF
	TYPE	Data type	IUNS	4	0	16	0102
	PARM	Parameter	IUNS	5	0	16	0000
	FRMTRM	Frame trm	IUNS	6	0	16	0000
	FILL	Cmd pad	SUND	7	0	14	DEADBEEF
AMS0003	FRMHDR	Frame hdr	IUNS	1	0	16	2000
	BCOUNT	Byte count	IUNS	2	0	16	0006

Command	Field	Description	Type	Byte	Bit	Len	Contents
AMS_STANDBY	BTNODE	Block hdr	IUNS	3	0	16	82FF
	TYPE	Data type	IUNS	4	0	16	0103
	PARM	Parameter	IUNS	5	0	16	0000
	FRMTRM	Frame trm	IUNS	6	0	16	0000
	FILL	Cmd pad	SUND	7	0	14	DEADBEEF
AMS0004 AMS_MAGWDT	FRMHDR	Frame hdr	IUNS	1	0	16	2000
	BCOUNT	Byte count	IUNS	2	0	16	0006
	BTNODE	Block hdr	IUNS	3	0	16	82FF
	TYPE	Data type	IUNS	4	0	16	0104
	PARM	WDT time	IUNS	5	0	16	
	FRMTRM	Frame trm	IUNS	6	0	16	0000
	FILL	Cmd pad	SUND	7	0	14	DEADBEEF
AMS0005 AMS_PWRSTEP	FRMHDR	Frame hdr	IUNS	1	0	16	2000
	BCNT	Byte count	IUNS	2	0	16	0006
	BTNODE	Block hdr	IUNS	3	0	16	82FF
	DTYPE	Data type	IUNS	4	0	16	0105
	PARM	Power step	IUNS	5	0	16	0
	FRMTRM	Frame trm	IUNS	6	0	16	0000
	FILL	Cmd pad	SUND	7	0	14	DEADBEEF
AMS0006 AMS_OPSSTATE	FRMHDR	Frame hdr	IUNS	1	0	16	2000
	BCOUNT	Byte count	IUNS	2	0	16	0006
	BTNODE	Block hdr	IUNS	3	0	16	82FF
	TYPE	Data type	IUNS	4	0	16	0106
	PARM	Ops state	IUNS	5	0	16	
	FRMTRM	Frame trm	IUNS	6	0	16	0000
	FILL	Cmd pad	SUND	7	0	14	DEADBEEF
AMS0007 AMS_COMSTATE	FRMHDR	Frame hdr	IUNS	1	0	16	2000
	BCOUNT	Byte count	IUNS	2	0	16	0006
	BTNODE	Block hdr	IUNS	3	0	16	82FF
	TYPE	Data type	IUNS	4	0	16	0107
	PARM	Comm state	IUNS	5	0	16	
	FRMTRM	Frame trm	IUNS	6	0	16	0000
	FILL	Cmd pad	SUND	7	0	14	DEADBEEF
AMS0008 AMS_POCC	AMSFRAME	Frame	SUND	1	0	106	0
AMS0009 AMS_POCC_V	FRAME	Frame	SUND	1	0		
AMS0010 AMS_GENERIC	FRMHDR	AMSFrame header	IUNS	1	0		2000
AMS0011 AMS_STRING	FRMHDR	Frame hdr	IUNS	1	0	16	2000
	BCOUNT	Byte count	IUNS	2	0	16	0060
	BTNODE	Block hdr	IUNS	3	0	16	82FF
	TYPE	Data type	IUNS	4	0	16	010B
	STRING	String	SASC	5	0	96	
	FRMTRM	Frame trm	IUNS	53	0	16	0000
AMS0012 AMS_PARM1	FRMHDR	Frame hdr	IUNS	1	0	16	2000
	BCOUNT	Byte count	IUNS	2	0	16	0006
	BTNODE	Block hdr	IUNS	3	0	16	82FF
	TYPE	Data type	IUNS	4	0	16	010C
	PARM	Parameter	IUNS	5	0	16	
	FRMTRM	Frame trm	IUNS	6	0	16	0000
	FILL	Cmd pad	SUND	7	0	14	DEADBEEF
AMS0013 AMS_PARM	FRMHDR	Frame hdr	IUNS	1	0	16	2000
	BCOUNT	Byte count	IUNS	2	0	16	0006
	BTNODE	Block hdr	IUNS	3	0	16	82FF

Command	Field	Description	Type	Byte	Bit	Len	Contents
	TYPE	Data type	IUNS	4	0	16	010D
	PARM	Parameter	IUNS	5	0	16	
	FRMTRM	Frame trm	IUNS	6	0	16	0000
	FILL	Cmd pad	SUND	7	0	14	DEADBEEF
AMS0014 AMS_PARM3	FRMHDR	Frame hdr	IUNS	1	0	16	2000
	BCOUNT	Byte count	IUNS	2	0	16	0006
	BTNODE	Block hdr	IUNS	3	0	16	82FF
	TYPE	Data type	IUNS	4	0	16	010E
	PARM	Parameter	IUNS	5	0	16	
	FRMTRM	Frame trm	IUNS	6	0	16	0000
	FILL	Cmd pad	SUND	7	0	14	DEADBEEF
AMS0015 AMS_PARM4	FRMHDR	Frame hdr	IUNS	1	0	16	2000
	BCOUNT	Byte count	IUNS	2	0	16	0006
	BTNODE	Block hdr	IUNS	3	0	16	82FF
	TYPE	Data type	IUNS	4	0	16	010F
	PARM	Parameter	IUNS	5	0	16	
	FRMTRM	Frame trm	IUNS	6	0	16	0000
	FILL	Cmd pad	SUND	7	0	14	DEADBEEF
AMS0016 AMS_PARM5	FRMHDR	Frame hdr	IUNS	1	0	16	2000
	BCOUNT	Byte count	IUNS	2	0	16	0006
	BTNODE	Block hdr	IUNS	3	0	16	82FF
	TYPE	Data type	IUNS	4	0	16	0110
	PARM	Parameter	IUNS	5	0	16	
	FRMTRM	Frame trm	IUNS	6	0	16	0000
	FILL	Cmd pad	SUND	7	0	14	DEADBEEF

Figure 75 PDL Command Fields

27 Payload Data Library Reports – Telemetry

AMS0001	SubsetID	N	IUNS	16	Bits	INTEGR	0	65535
AMS0002	PEPSrvCID	N	IUNS	16	Bits	INTEGR	0	65535
AMS0003	PEPData	N	IUNS	16	Bits	INTEGR	0	65535
AMS0004	CW	N	IUNS	16	Bits	INTEGR	0	65535
AMS0005	FS_LINK	N	IUNS	16	Bits	INTEGR	0	65535
AMS0006	CHD01	N	IUNS	8	Bits	INTEGR	0	255
AMS0007	CHD02	N	IUNS	8	Bits	INTEGR	0	255
AMS0008	CHD03	N	IUNS	8	Bits	INTEGR	0	255
AMS0009	CHD04	N	IUNS	8	Bits	INTEGR	0	255
AMS0010	CHD05	N	IUNS	8	Bits	INTEGR	0	255
AMS0011	CHD06	N	IUNS	8	Bits	INTEGR	0	255
AMS0012	CHD07	N	IUNS	8	Bits	INTEGR	0	255
AMS0013	CHD08	N	IUNS	8	Bits	INTEGR	0	255
AMS0014	CHD09	N	IUNS	8	Bits	INTEGR	0	255
AMS0015	CHD10	N	IUNS	8	Bits	INTEGR	0	255
AMS0016	AMSBlock	N	IUND	16	Bits			

Figure 76 PDL Telemetry Fields

	Name	Type	Byte	Bit	Len
AMS0002	PEPSrvCID	IUNS	1	0	16
AMS0003	PEPData	IUNS	2	0	16
AMS0004	CW	IUNS	3	0	16
AMS0005	FS_LINK	IUNS	4	0	16
AMS0006	CHD01	IUNS	5	0	8
AMS0007	CHD02	IUNS	5	8	8
AMS0008	CHD03	IUNS	6	0	8
AMS0009	CHD04	IUNS	6	8	8
AMS0010	CHD05	IUNS	7	0	8
AMS0011	CHD06	IUNS	7	8	8
AMS0012	CHD07	IUNS	8	0	8
AMS0013	CHD08	IUNS	8	8	8
AMS0014	CHD09	IUNS	9	0	8
AMS0015	CHD10	IUNS	9	8	8
AMS0016	AMSBlock	IUND	10	0	16

Figure 77 Health and Status Subset Fields

28 Verification Matrix

Validation Product # ²⁸	Activity ²⁹	Objective ³⁰	Valid. Method ³¹	Facility or Lab ³²	Phase ³³	Perform. Org ³⁴	Results ³⁵
1	STEP Test	Gross assessment of 1553 functionality for ISS.	Test	AMS Integration Lab	1	AMS	Passed
2	PIT Test: RT Validation Test	Ensure 1553 protocol requirements	Test	AMS Integration Lab	2	Boeing /AMS	Passed
3	PIT Test: Taxiscopes Test	Verify low level protocol and error handling requirements.	Test	AMS Integration Lab	2	Boeing /AMS	Passed
4	PIT Test: APS Testing	Verify compatibility of interface with APS and evaluate loss of sync issues	Test	AMS Integration Lab	2	Boeing /AMS	Passed
5	PIT Test: OIU Lab Test	Verify functionality of 1553 interfaces with OIU (Command and Telemetry)	Test	JSC OIU Lab	2	USA/ AMS	Passed
6	FIT Test: ISS Interface Verification	Functional interface testing with AMS-02 Command and Data front-end (Qual Unit J-Crate) and ACOP Low Fidelity Model	Test	KSC PTCS	3		
6a	1553 Data Throughput	Ensure compatibility with PLMDM, and data flow through EHS to POCC GSE	Test	KSC PTCS	3		
6b	1553 Command	Verify flow through EHS, PLMDM to AMS front-end hardware	Test	KSC PTCS	3		
6c	HRDL Downlink	Verification of HRDL transmission from AMS front-end hardware through APS to downlink to EHS and POCC GSE	Test	KSC PTCS	3		

²⁸ Unique identifier for validation product

²⁹ Describe evaluation by the customer/sponsor that will be performed

³⁰ What is to be accomplished by the customer/sponsor evaluation

³¹ Validation Method for the System X requirement (Analysis, Inspection, Demonstration, or Test)

³² Facility or laboratory used to perform the validation

³³ Phase in which the verification/validation will be performed:

Example:

1. During product selection process
2. Prior to final product selection (if COTS) or prior to PDR
3. Prior to CDR
4. During box-level Functional
5. During System-level Functional
6. During end-to-end Functional
7. During Integrated Vehicle Functional
8. During On-orbit Functional

³⁴ Organization responsible for coordinating the validation activity

³⁵ Indicate the objective evidence that validation activity occurred

Validation Product # ²⁸	Activity ²⁹	Objective ³⁰	Valid. Method ³¹	Facility or Lab ³²	Phase ³³	Perform. Org ³⁴	Results ³⁵
6d	HRDL Communications AMS to/from ACOP	Verification of bi-directional data flow from AMS to ACOP and ACOP to AMS all through APS	<i>Test</i>	KSC PTCS	3		
6e	ACOP burst rate verification	Validation of ACOP burst through APS, downlink, EHS, to POCC GSE	<i>Test</i>	KSC PTCS	3		
7	FIT Test: STS Interface Verification	Functional interface testing with AMS-02 Command and Data front-end (Qual Unit J-Crate) and Digital Data Recorder System (DDRS-02)	<i>Test</i>	KSC CITE Stand	3		
7a	1553 communications with OIU	Validate: Data flow from AMS front-end hardware through OIU/PDI to ground support equipment Command from GSE through PSP/OIU to AMS front-end hardware	<i>Test</i>	KSC CITE Stand	3		
7b	1553 communications T0 interface	Command and telemetry flow between AMS front-end and POCC GSE via T0 interface hardware	<i>Test</i>	KSC CITE Stand	3		
7c	RS-422 flow to AFD	Validation of data recording via Digital Data Recorder System-02	<i>Test</i>	KSC CITE Stand	3		
7d	RS-422 flow to downlink	Validation of data flow through T0 or Ku to POCC GSE	<i>Test</i>	KSC CITE Stand	3		
9	KSC Interface Test	Validation of STS and ISS interfaces with entire payload prior to installation in STS Cargo Bay	<i>Test</i>	KSC SSPF	4		
9a	ISS Interfaces	Validation of 1553 communications and HRDL communications with full experiment	<i>Test</i>	KSC PTCS	4		
9b	STS Interfaces	Validation of 1553 communications and RS-422 communications with full experiment	<i>Test</i>	KSC CITE Stand	4		
10	STS End to End Test	End to End test performed during Pad activities with AMS-02 in Payload Bay to verify STS interfaces	<i>Test</i>	In Orbiter on Pad	5		

Figure 78 Verification Matrix