

The Linde logo is written in a white, elegant, cursive script font. The background of the slide is a deep blue with a pattern of thin, white, curved lines that create a sense of depth and movement, resembling a stylized globe or a network of connections.

Linde Engineering Division

Welcome

Phone : ++49 89 7445 0
Telefax : ++49 89 7445 4908
Email : info@linde-le.com
Internet : www.linde.com

The Linde Group



Linde Engineering



Linde Gas



Material Handling



Refrigeration

Linde Group Sales

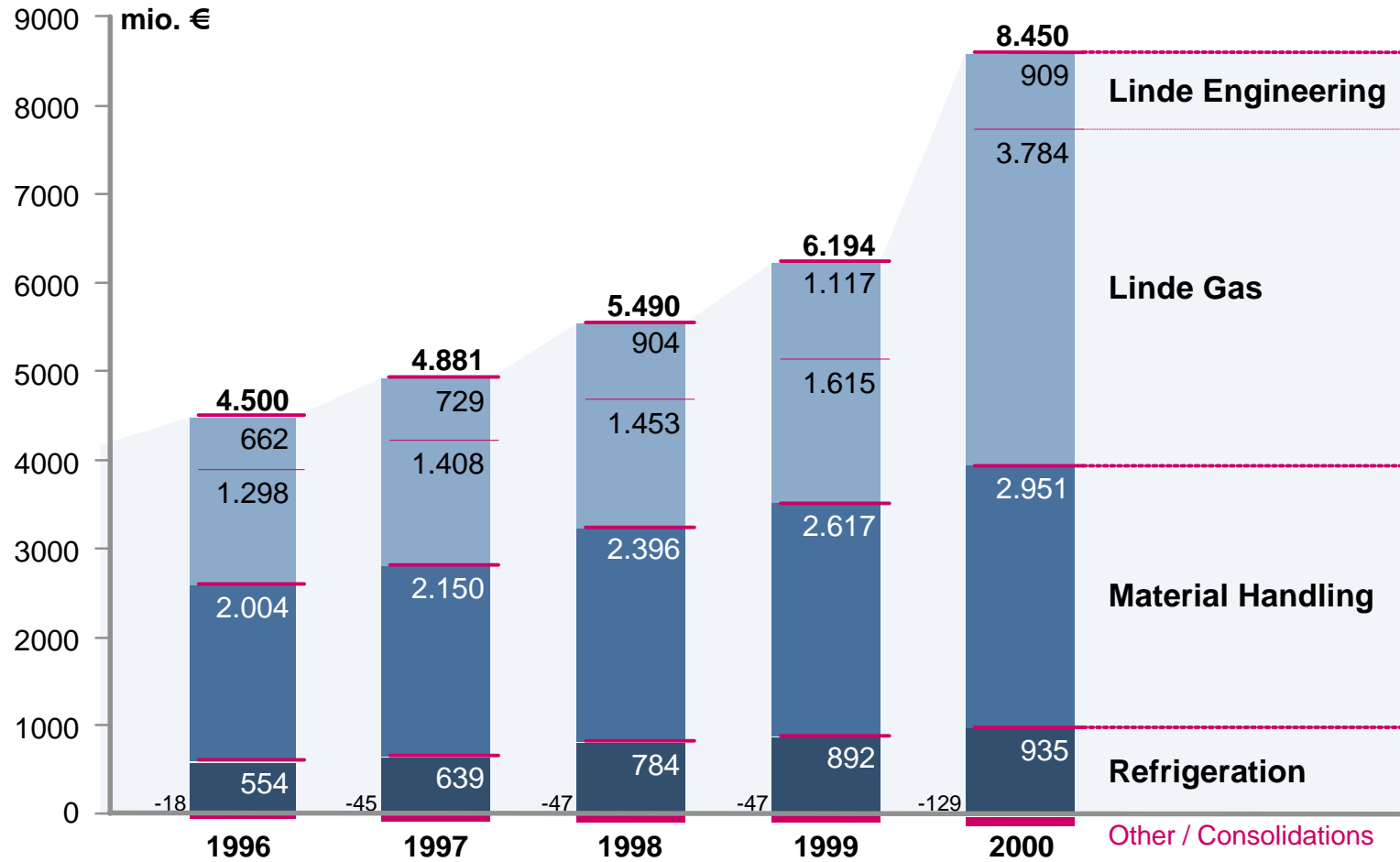

AMS-02

Passive Phase Separator



Linde's Participation on Space Projects

- 1977 - 1980 GIRL (German Infra-Red Laboratory)
- 1980 - 1995 ISO (Infrared Space Observatory)
- 1994 - 2003 MELFI (Minus eighty deg. Laboratory Freezer) for ISS
- 2001 - AMS (Alpha Magnetic Spectrometer) for ISS
- 2001 - 2007 HERSCHEL (Far-Infrared and Submillimeter Telescope)

AMS-02

Passive Phase Separator



Infrared Space Observatory, ISO

LINDE scope of delivery:

- Process layout, design, manufacture and space qualification of the Helium Subsystem
- Supply of the cryo-vacuum ground support equipment
- Support to system tests

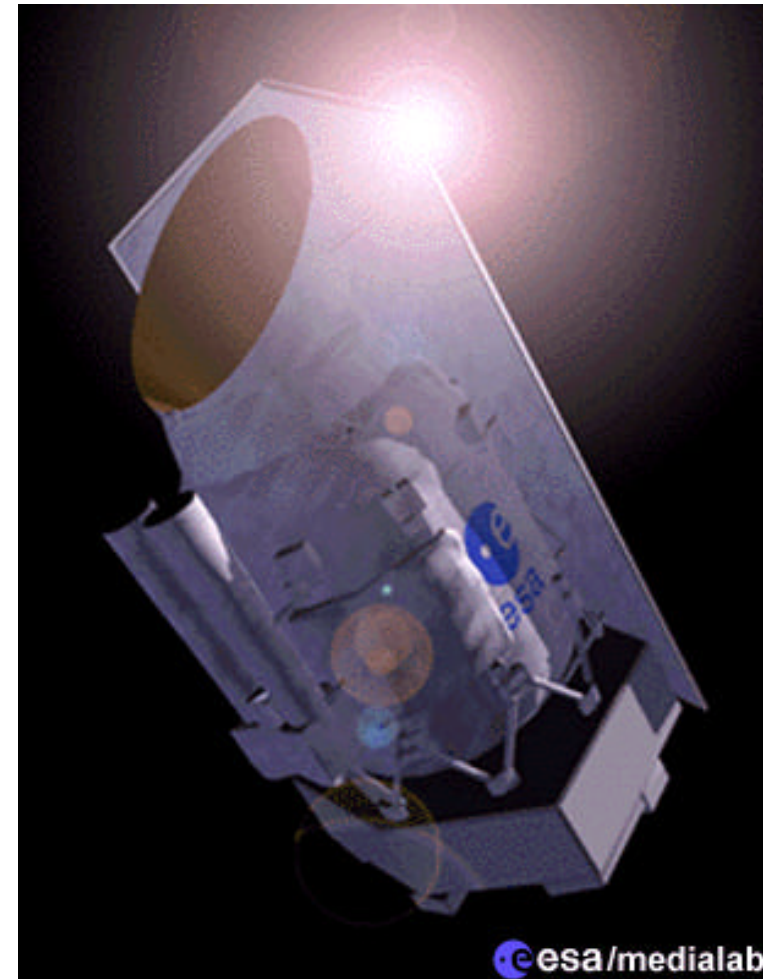

AMS-02

Passive Phase Separator



Helium Subsystem of ISO

- Helium volume:
 - 2.250 l (main tank)
 - 60 l (auxiliary tank)
- Operational temperature:
 - 1,8 K (main tank) superfluid
 - 4,2 K (auxiliary tank)
- Cryo-autonomy:
 - 72 h before launch
- Cryo hold time:
 - 18 months (specified)
 - 28.3 months (actual lifetime)

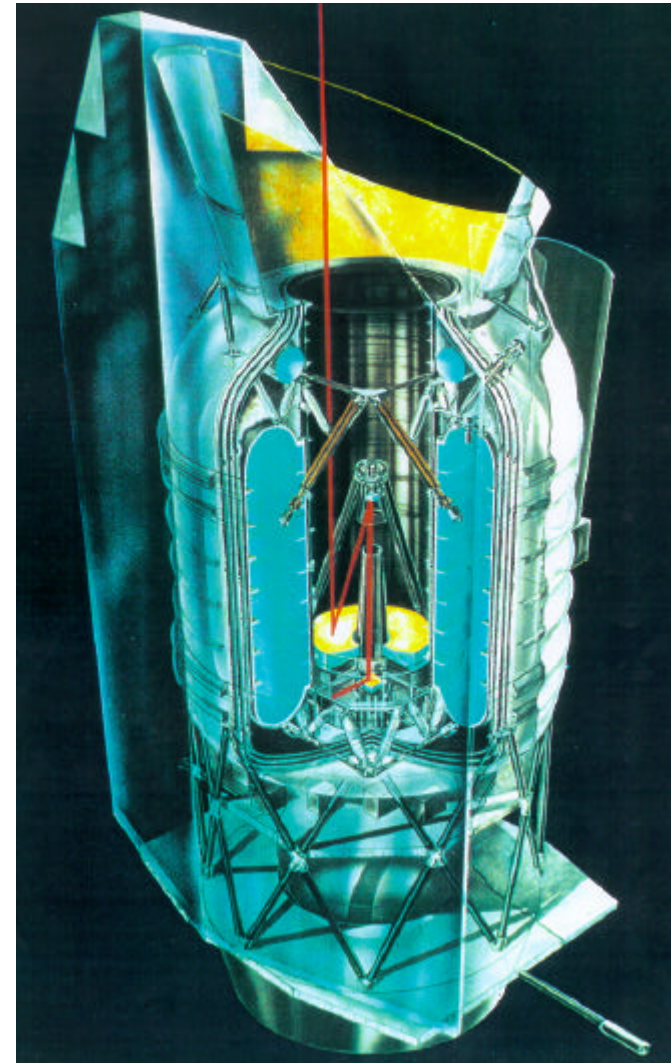

AMS-02

Passive Phase Separator



Thermomechanical Effect Schematic

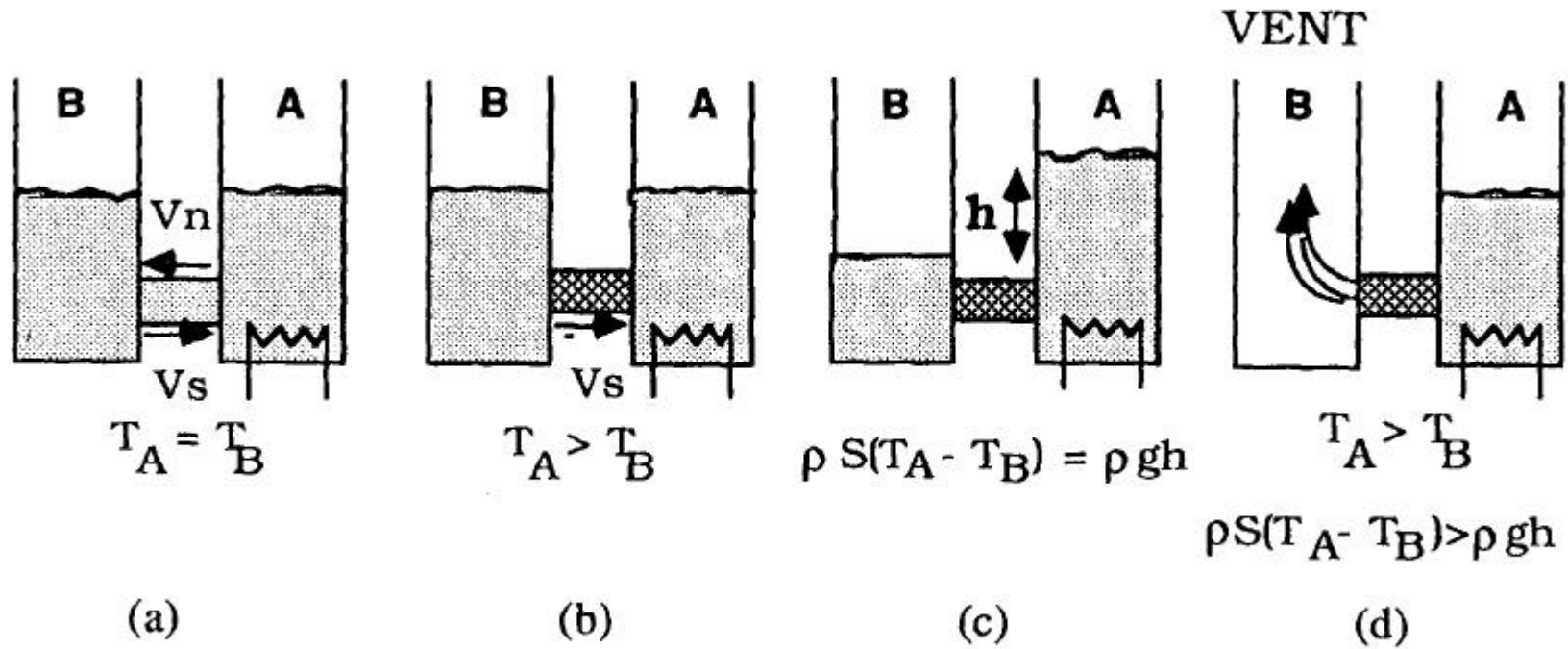

AMS-02 Passive Phase Separator



Phase Separation

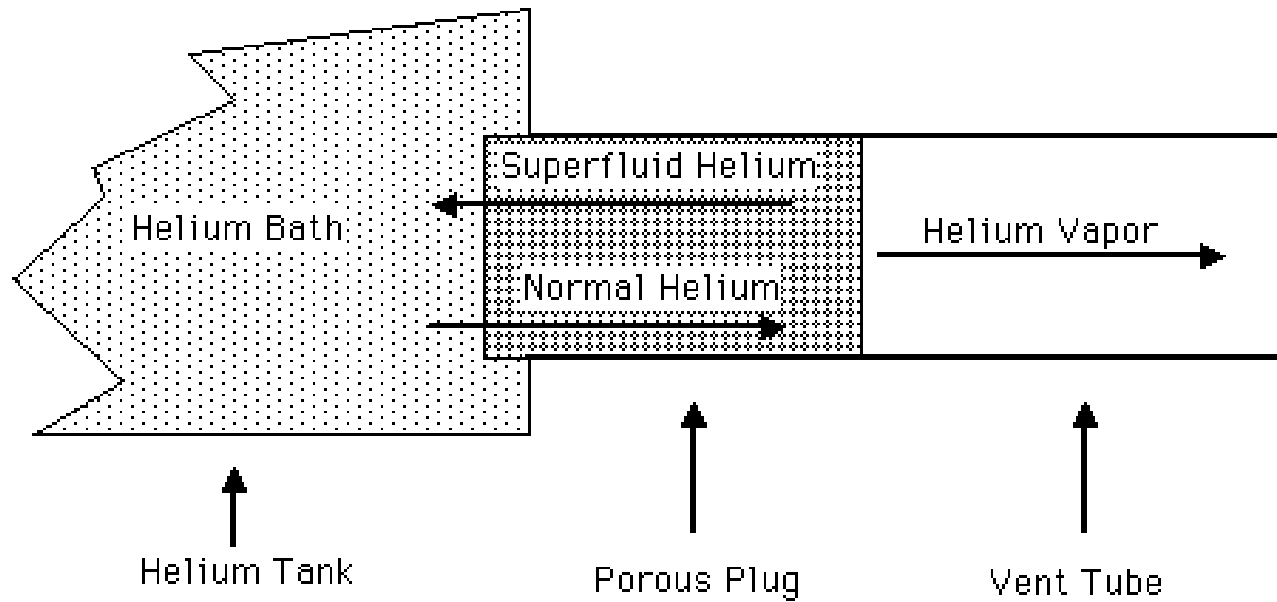

AMS-02

Passive Phase Separator



Theoretical Consideration (M. Murakami et al)

- Small Pressure and Temperature Region

$$\frac{d}{dt}m = A \cdot \frac{r \cdot S \cdot T \cdot Kp}{(L + S \cdot T) \cdot hn \cdot l} \cdot \Delta P$$

- Large Pressure and Temperature Region

$$\frac{d}{dt}m = A \cdot \frac{rv \cdot Kp}{hv \cdot l} \cdot \Delta P$$

AMS-02

Passive Phase Separator



Schematic test set-up

- LHe-glass cryostat
- Moveable glass sample holder
- One pump for He bath
- One pump for porous plug
- Liquid-gas sensor LG

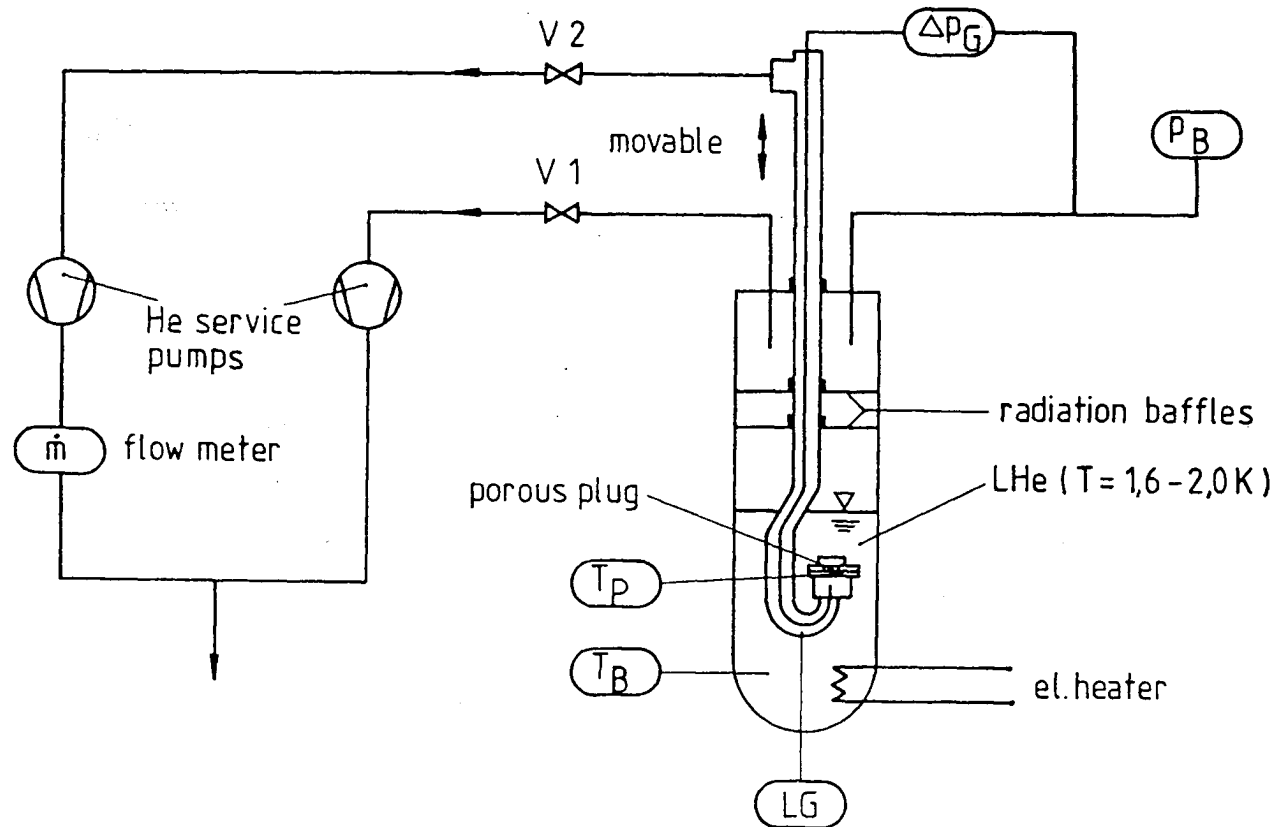

AMS-02

Passive Phase Separator



Detailed sketch of the sample holder

- He flow through the porous plug is from top to bottom
- By this arrangement any accumulation of liquid on the down-stream side is excluded
- Liquid breakthrough can easily be detected

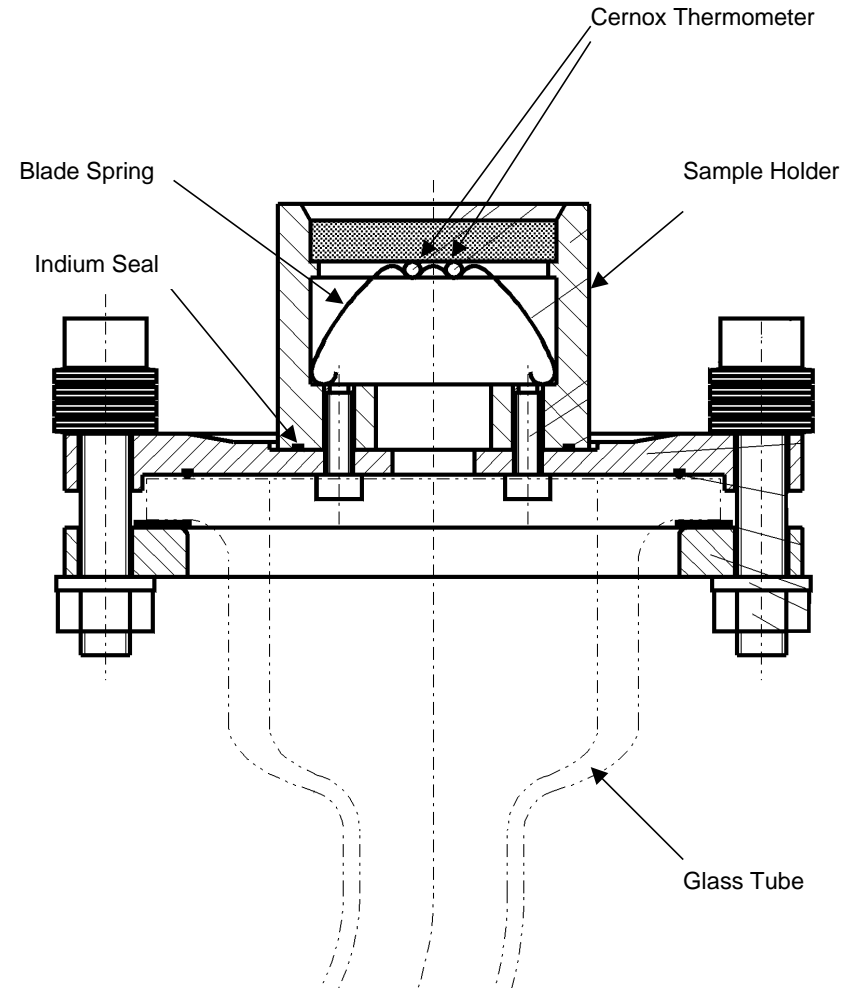

AMS-02 Passive Phase Separator



AMS-02

Passive Phase Separator



- Sintered stainless steel samples are thermally shrunk into a stainless steel housing



AMS-02 Passive Phase Separator



Phase separator consists of

- Sintered stainless steel porous plug
- Housing
- Instrumentation

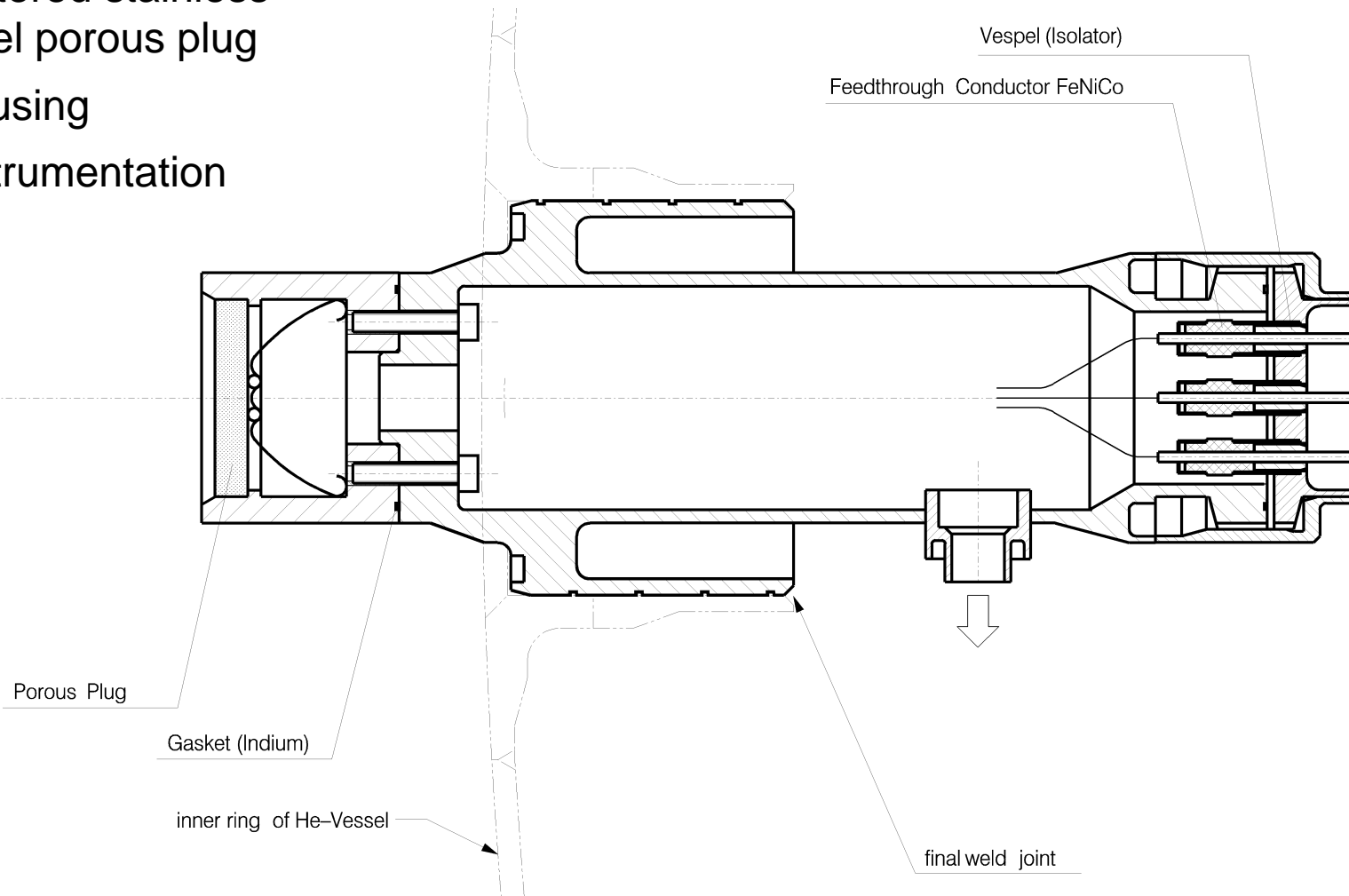

AMS-02

Passive Phase Separator



Characteristic mass flow as function of the pressure drop across the plug measured for three constant bath temperatures

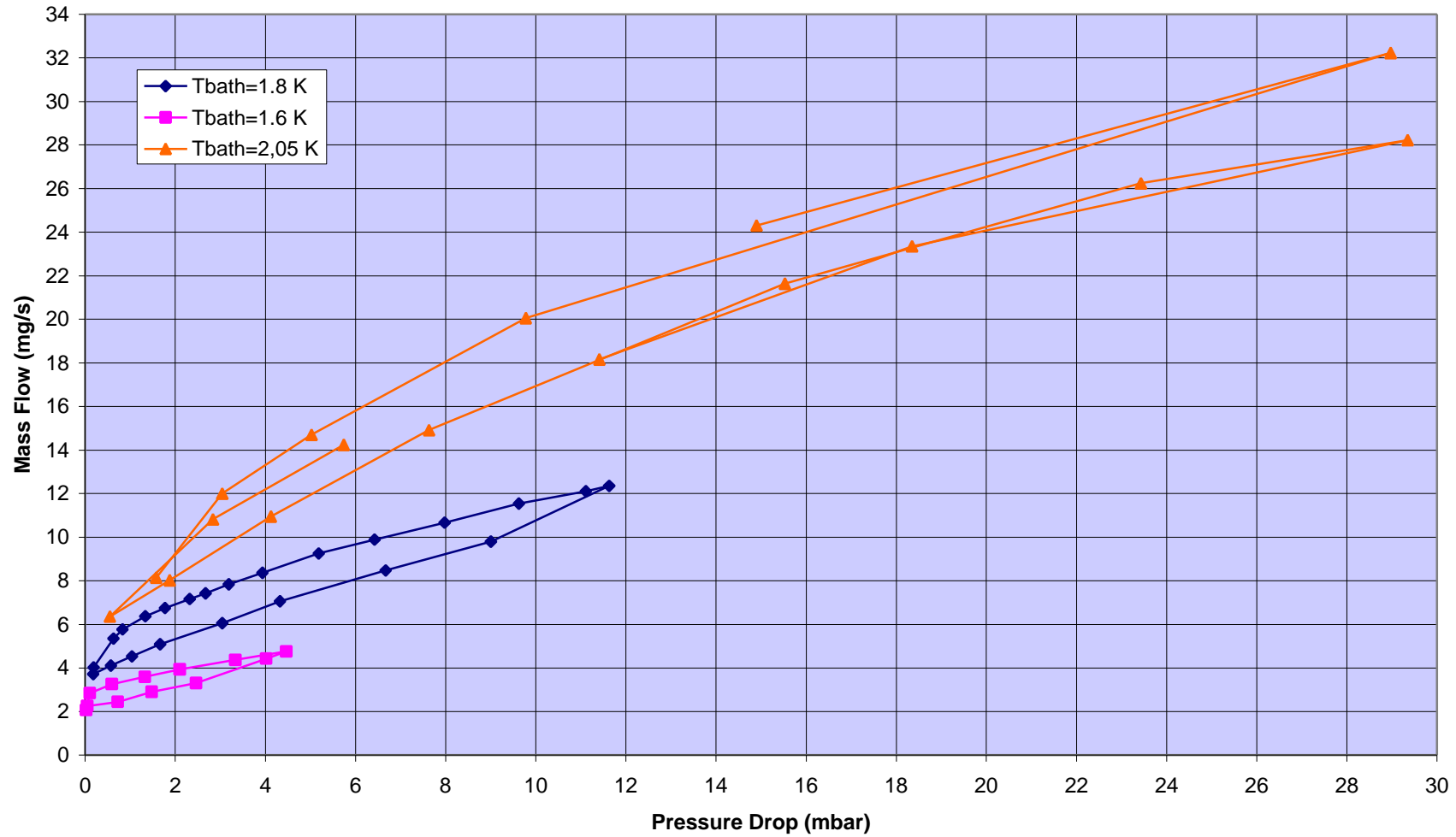

AMS-02 Passive Phase Separator



Characteristic mass flow as function of the temperature difference across the plug
measured for three constant bath temperatures

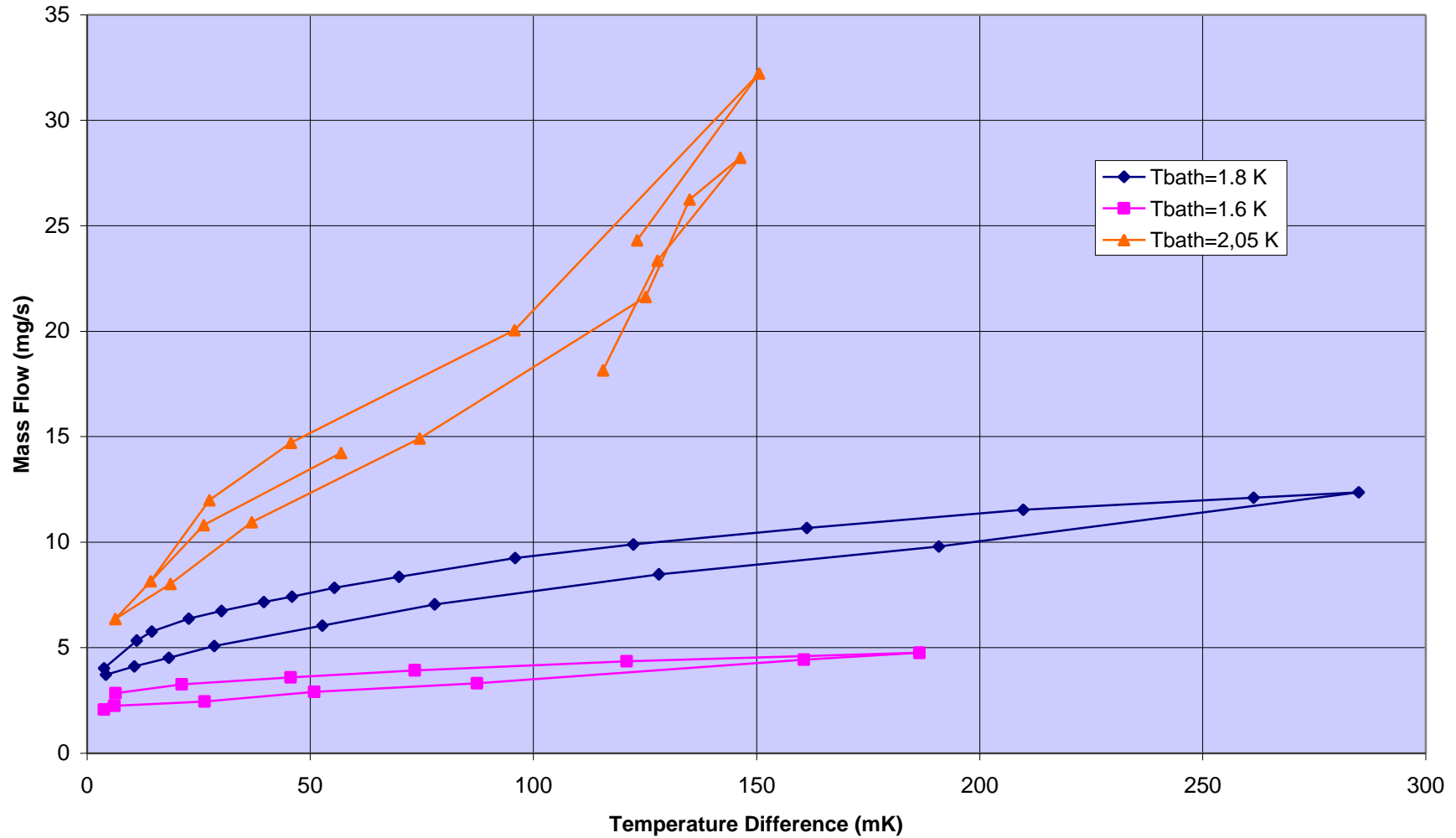

AMS-02 Passive Phase Separator



Charateristic mass flows as function of the pressure drop across the porous plug
measured at two different constant positions of the vent valve

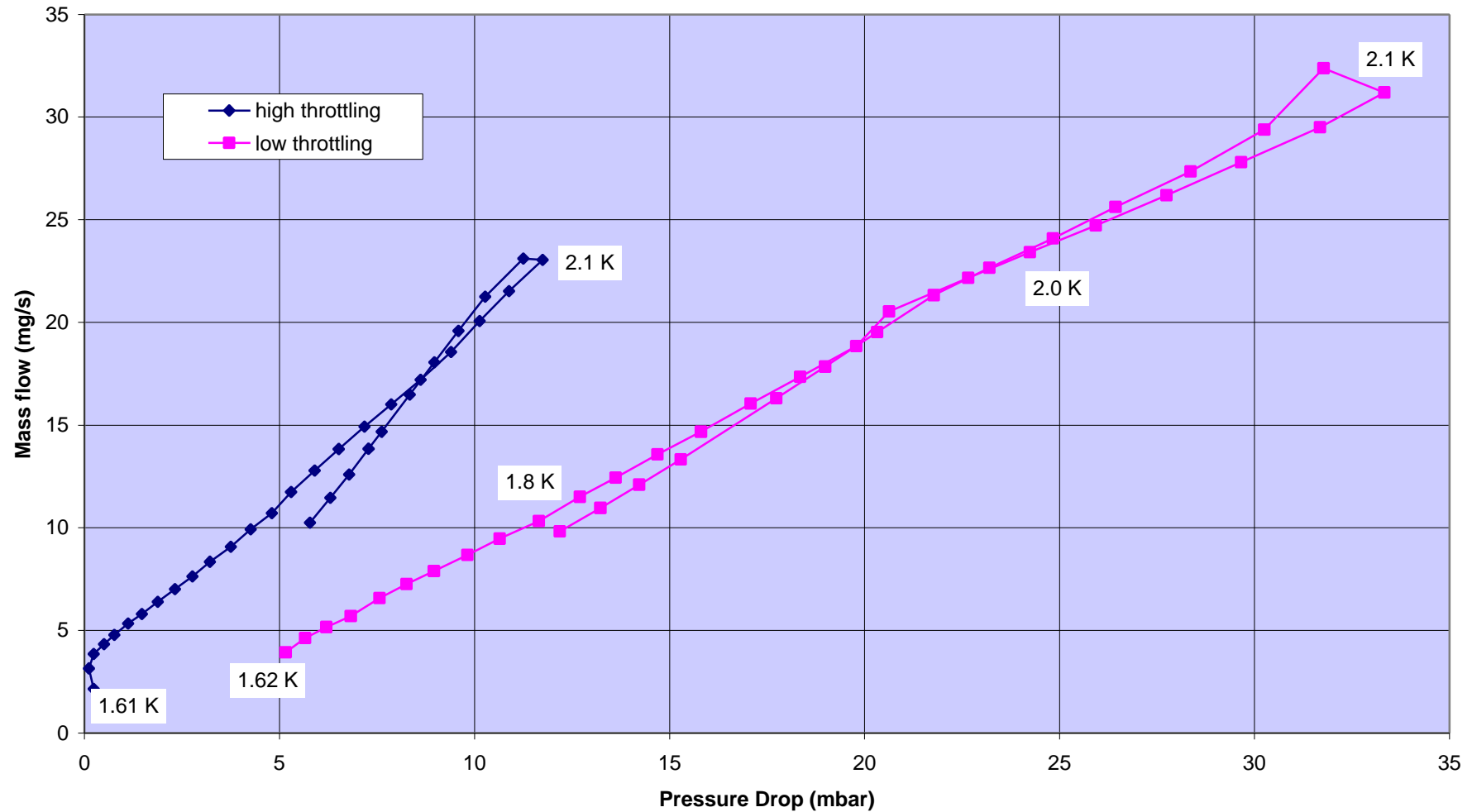

AMS-02

Passive Phase Separator



Conclusion

- The selected plug worked in normal phase separation mode without any leakage
- The specified mass flow range of 4 to 17 mg/s could be reached for the operational He II bath temperature range between 1.6 K and 2.0 K
- The phase separator housing has still to be modified to fit to AMS He II tank requirements