

Software Status of AMS02 Main DAQ Computer

Xudong CAI, MIT

May 2002

Hardware Architecture

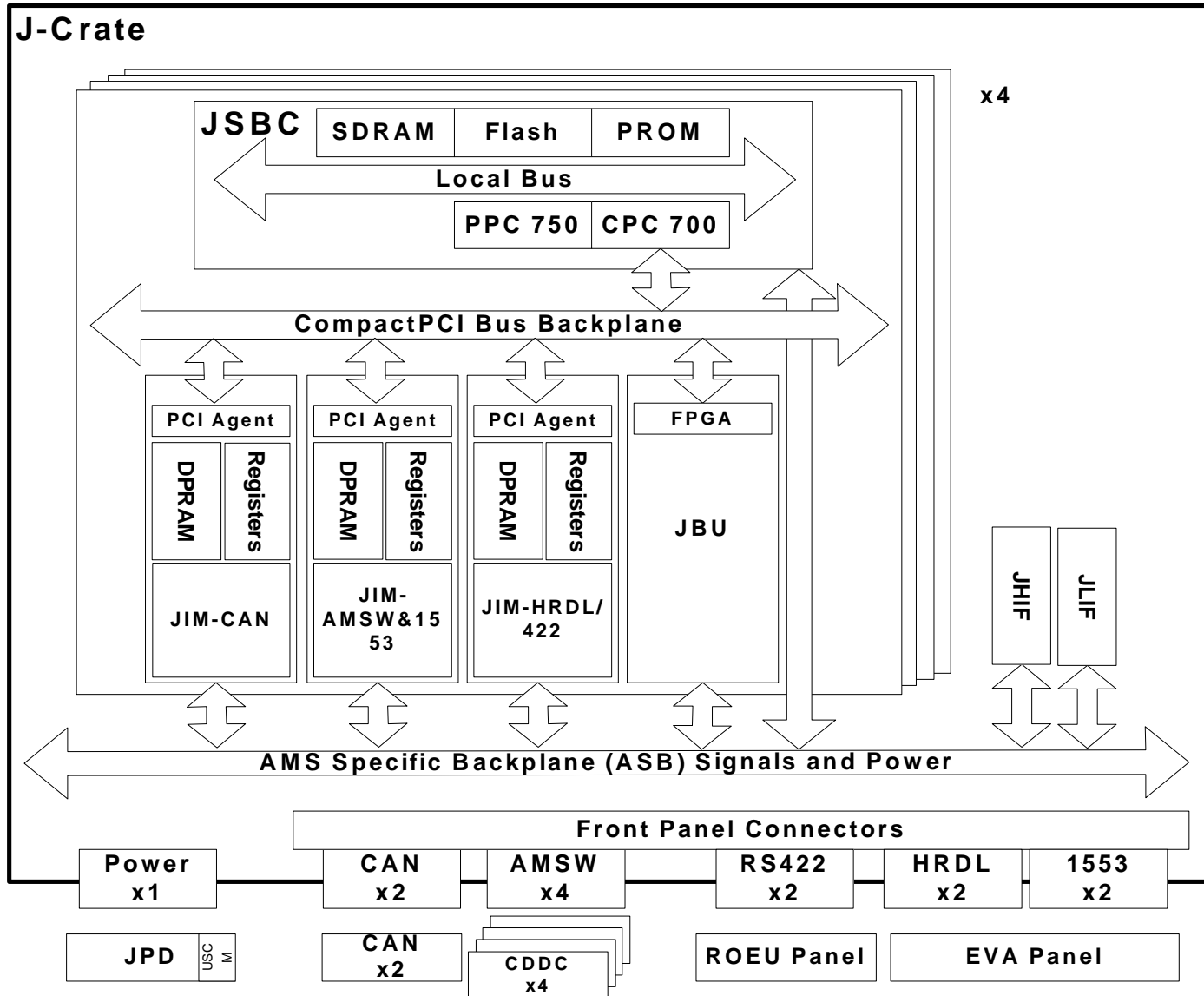

Software Architecture

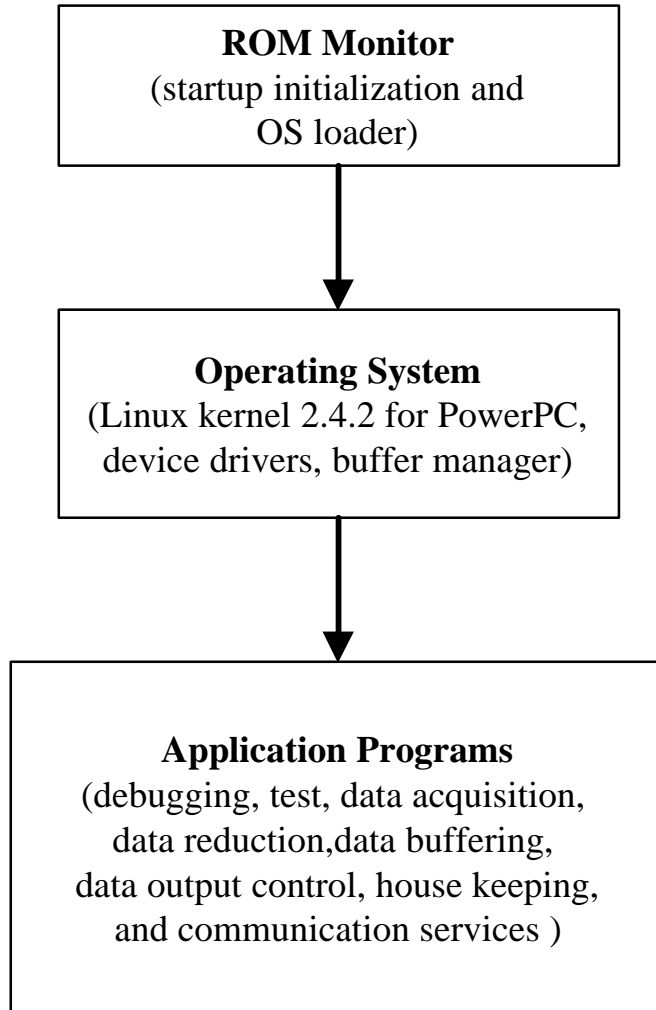

Outline of JMDC Software Status

- **ROM Monitor**
- **Linux kernel**
- **Device drivers and debugging programs**
- **File systems**
- **Application Programs**

ROM Monitor Status

- **System initialization is OK**
- **Serial port boot is supported (only for debugging phase)**
- **Ethernet boot is supported (only for debugging phase)**
- **Flash memory boot is supported. Boot files can be selected.**
- **Flash file system JFFS2 is partially supported. Further study is needed.**
- **Flash memory read and write is supported.**
- **Accessing JIM-AMSWIRE prototype board is done. The device driver need to be finalized. Boot from JIM-AMSWIRE is not supported yet.**
- **Software reboot problem is fixed.**
- **The ROM Monitor can be built with GNU compiler. It will not have size limitation from HighC compiler anymore.**
- **The current program size is about 80 kbytes.**
- **The estimated final size will be less than 128 kbytes. This will fit the current JSBC PROM size.**

Linux Kernel

- **Linux kernel porting to the target system is done. Following problems are fixed.**
 - **Memory mapping problem. We have defined the address map for PowerPC DBAT registers, CPC700 registers and flash memory.**
 - **CPC700 initialization problem**
 - **CPC700 byte swapping problem**
 - **User allocate kernel memory problem is fixed by using a buffer manager device driver. The buffer allocated by this driver can be used by user's applications and can be used directly by DMA operations.**
 - **PCI command for burst transfer is defined. All JIM and JBU boards should support "memory read line" (1110) and "memory write and invalidate" (1111) in both master and target modes.**
- **Two system environments are prepared.**
 - **Full network support and NFS file system support**
 - **Embedded system by using RAM disk**
- **Further Study**
 - **Task scheduling**
 - **Real-time options**

JMDC Address Map

- 0x00000000 - 0x1fffffff : System memory space (physical)
 - 0x20000000 - 0x21fffffff : Flash memory space (physical)
 - 0x30000000 - 0x4fffffff : Virtual memory space for tasks
 - 0x80000000 - 0x9fffffff : JBU PCI memory space
 - 0xc0000000 - 0xebffffff : Kernel virtual memory space
 - 0xec000000 - 0xedffffff : Flash memory virtual space
 - 0xf0000000 - 0xf7ffffff : Other PCI memory space
 - 0xf8000000 - 0xfbffffff : PCI I/O space
 - 0xfec00000 - 0xfecffffff : PCI Configure space
 - 0xff400000 - 0xff5ffffff : CPC700 Configure Registers
 - 0xff600000 - 0xff7ffffff : Internal Peripherals
 - 0xff800000 - 0xffdffffff : Control/Status registers
 - 0xffe00000 - 0xffffffff : Boot PROM
-
- All DBAT Registers and IOREMAP are defined according to this.

Device Drivers and Debugging Programs

- **Device drivers:**
 - The preliminary device drivers for all JIM and JBU boards are done.
 - JBU block device driver is ready.
 - Device task queue mode need to be studied.
- **Debugging programs:**
 - JIM-AMSWIRE debugging programs are ready and used by hardware designers.
 - HRDL part of JIM-HRDL/422 debugging programs are ready and used by firmware designer.
 - A simple general debugging programs suitable for all boards have been prepared by Mr.Xu. It can access dual-port memory and registers. It is used by hardware and firmware designers.
 - The debugging programs for JIM-CAN is in progress. Because we just got the 8051 software before this meeting.
 - The debugging programs for JBU will be done by the end of June 2002.

File systems

- **JFFS2 file system for flash memory**
 - Both Linux side and ROM Monitor side can read, write, delete and format.
 - ROM Monitor still need further study to make fully support of JFFS2 file system.
 - Further tests on this file system is needed.
- **File system for JBU**
 - Unix ext2 and DOS FAT file systems were running over JBU.
 - The detail storing format of these file systems need to be studied.
 - File transfer between JSBC and JBU and between JIM-HRDL/422 and JBU should be studied.

Application Programs

- **We are not working on the application programs yet.**
- **We will make software in the following steps:**
 - **Debugging programs for each JIM and JBU board**
 - **Environmental test programs**
 - **Final studies of file systems for both flash memory and JBU**
 - **Task scheduling and device task queue studies**
 - **System performance test**
 - **Application programs**