

EUROPEAN ORGANIZATION FOR NUCLEAR RESEARCH

AMS Note SC-Tracker
2 December 2004

Slow control S9011AT and TPSFE boards

L.Accardo, S.Blasko

Abstract

This document describes the VHDL code written for the slow control in the Tracker electronics. Functionalities are reported and the architecture of the system is shown in a schematic format.

Comments to Lucio.Accardo@pg.infn.it

1 Description of the VHDL code for the S9011AT board

There are 2 LeCroy-slave units communicating with the T-crate, where JINF board is the master.

The 2 LeCroy units read or write data from/to registers using the “COM_BUS” 16 bit communication bus; to avoid possible conflicts, it has been needed an arbiter (CU_W_R_A_B) for the management of the access to the “COM_BUS”. The LeCroy_A unit has the priority on the LeCroy_B unit.

The bus is occupied only 1 cycle @ 4MHz (MASTER_CLK) for W/R operations; this is possible thanks to the VALID_DATA_TX signal, a pulse during 1 cycle of clock @ 4 MHz. It is generated at the falling edge of the DATA_CLK LeCroy communication signal (see PULSE_GEN module).

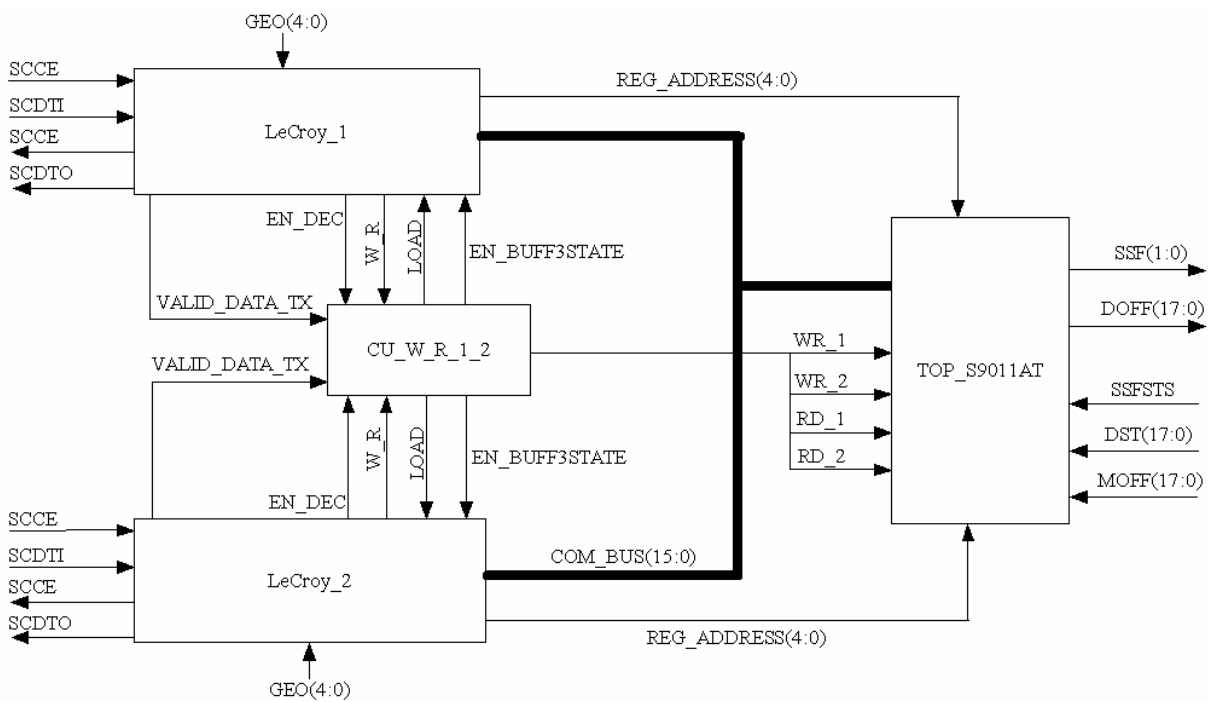

Figure 1

Top-level of the S9011AT's FPGA

1.1 LeCroy slave unit

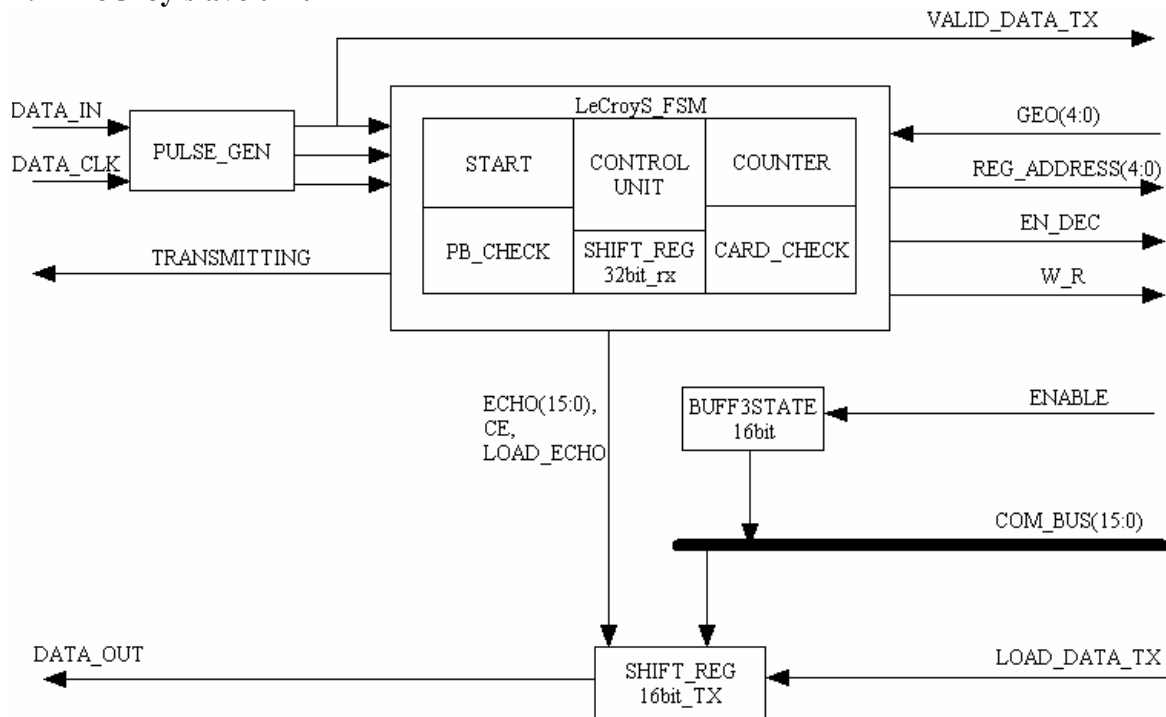

Figure 2

Top-level of the LeCroy slave unit

The LeCroy slave unit is composed by several sub-units, anyone doing its own function.

- *PULSE_GEN*: this module generates a pulse at the rising edge ($VALID_DATA_RX$, Fig. 3) and at the falling edge ($VALID_DATA_TX$) of $DATA_CLK$. These signals are then used as enables by the other modules, for the receiving and for the transmitting cycle respectively. Also the $DATA_IN$ signal is synchronized with $MASTER_CLK$ by using two D-type positive edge-triggered Flip-Flops. For the pulse generating, 3 flip-flops are used, to avoid metastability effects.

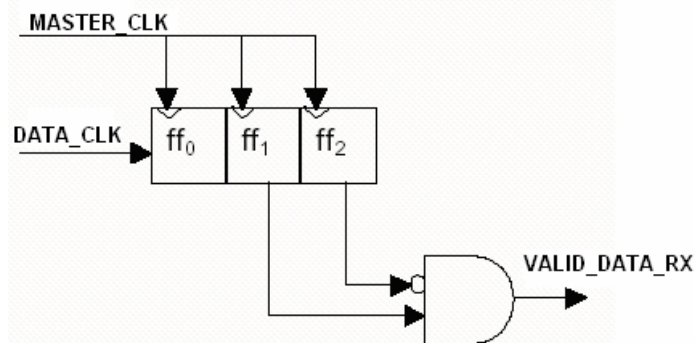

Figure 3

- *shiftreg_16bit_TX*: this is the 16-bit shift register used for transmitting data on the LeCroy interface. It has 2 different signal to load the data: $LOAD_ECHO$ allows the load of the 16

echo bits, while LOAD_DATA allows the load of the 16 data bits. The CE and VALID_DATA_TX signals allow the shift operations.

- *LeCroyS_FSM*: this is a finite state machine, composed by 4 states, describing the LeCroy protocol cycle. The initial state, “state0”, is the one set by the RESET_N active low signal. If a sequence of ‘0’ and ‘1’ is detected, then the cycle begins and the next state is “state_listening”. In this state, bits from the master are written in a shift register (shift_reg_32bit_rx), the parity bit is checked and a 6 bit counter is incremented. When the last bit is in the DATA_IN signal, then the CHIP_ADDRESS (GEO) is checked, together with the parity bit, and if the check is true, then the LOAD_ECHO and enable (CE) signals of the shiftreg_16bit_TX are asserted. The next state is state_reply. Otherwise, if the parity is wrong or the address is different from GEO signal, then next state is state_waiting. In the state_waiting, the counter is incremented but nothing is done; state0 is reached at the end of the 64-bit LeCroy cycle, to allow a new LeCroy cycle. In the state_reply, the LOAD_ECHO signal is negated, while the enable allows the shiftreg_16bit_TX to transmit the bits. One cycle before finishing the echo, the EN_DEC signal is asserted, to enable the decoder; this allows the reading of the 16-bit data to load (LOAD_DATA) on the shiftreg_16bit_TX. When finishing the 64-bit cycle, the state0 is reached, to allow a new LeCroy cycle. There is also a process that generates the TRANSMITTING (SCCE) signal for the LeCroy interface: VALID_DATA_TX signal allows this signal to be asserted.
- *buff3state_16bit*: this is a 16-bit buffer tri state; it is enabled from the arbiter to put its inputs (received data from LeCroy interface) on the “COM_BUS”.

1.2 Data handling architecture

The block TOP_S9011AT consists in a common bus architecture as shown in Fig. 4, with a decoder, the input buffers tri state and the write registers.

- *decoder_S9011AT*: it manages the enables of the registers (for writing operations) and the enables of the buffer tri state (for reading operations). There are 2 types of “reading enable” signals: one for the common inputs of the 2 LeCroy units and the other one for the auto clear registers, that must use different signals between the 2 LeCroy units. As a matter of fact, the auto clear registers are duplicated, to allow the auto clear function (see figure 1.4). The auto clear function is implemented with a D-type flip-flop: the registered input (enable) is used to clear the registers one cycle of clock after the reading operation.
- *SEL register*: it is auto clear, so it is cleared when it is read; it can also be cleared if it is written ‘1’ on the bit 0 of the register 0000 (CLEAR_SEL_1 and CLEAR_SEL_2).
- *glitch_det*: it is formed by 2 D-type flip-flops, one detecting the falling edge, and the other one detecting the rising edge of the input; the output is the OR of the 2 flip-flops outputs.
- *DST_L_trips and DST_H_trips registers*: they are composed by 9 glitch detectors (glitch_det).

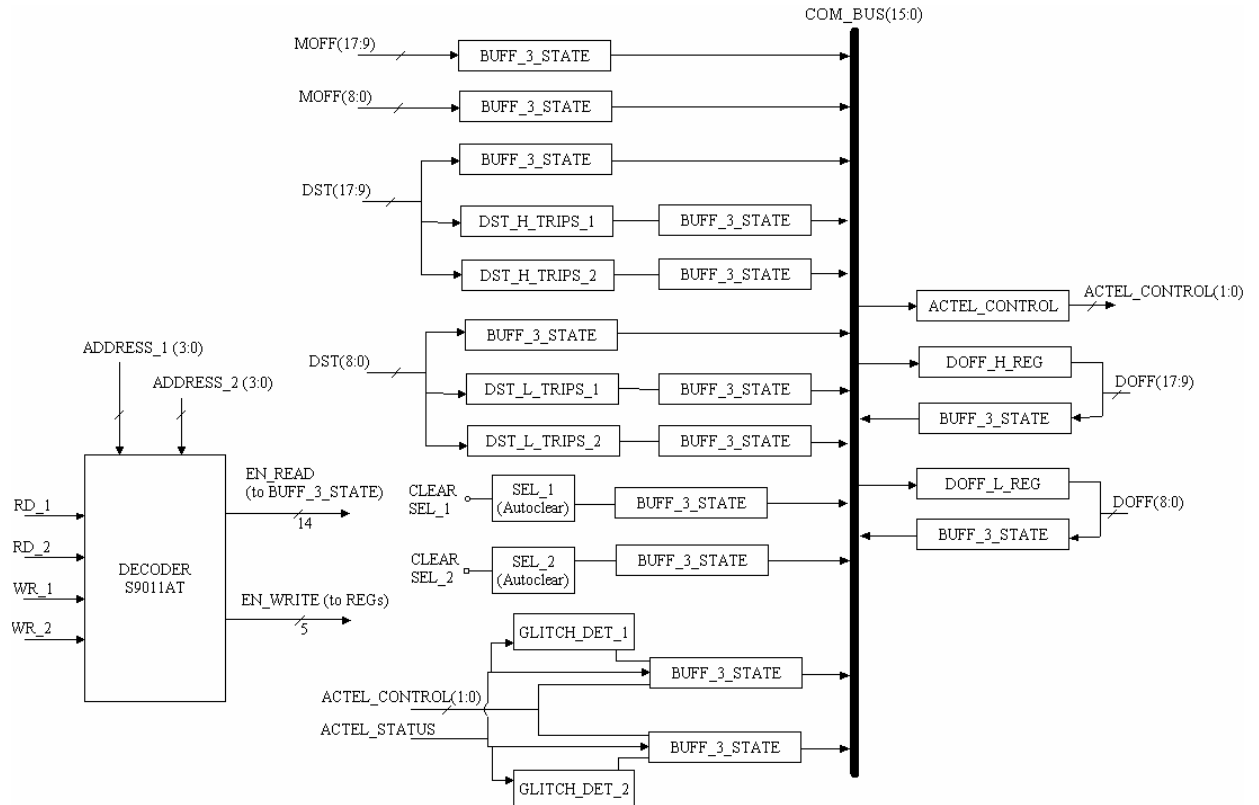

Figure 4

Common bus architecture of the S9011AT

- *DOFF_H reg and DOFF_L reg*: they can be written, and the last values can be read back through the buffer tri state.
- *ACTEL_CONTROL*: it is a special register with the default value 0002h.

2 Description of the VHDL code for the TPSFE board

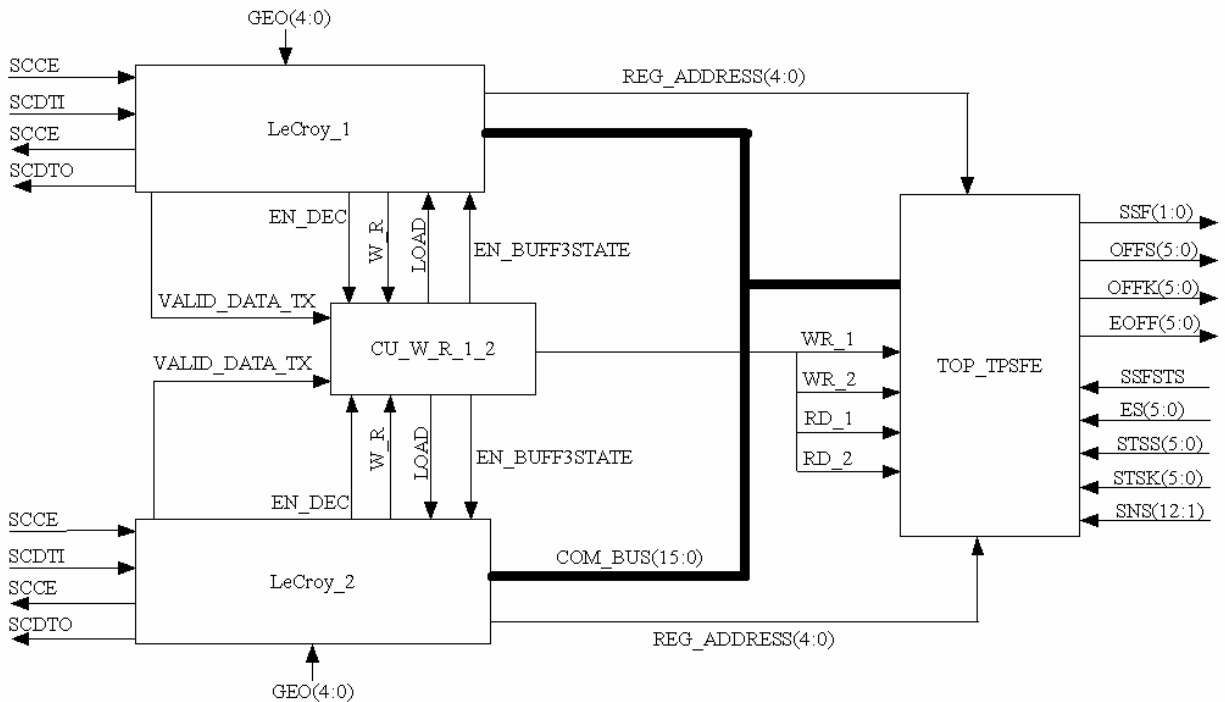

Figure 5

Top-level of the TPSFE's FPGA

2.1 Data handling architecture

The block TOP_TPSFE, shown in Fig. 6, consists in a common bus architecture, with a decoder, the input buffers tri state, the write registers and the TOP_COUNTERS block.

- decoder_TPSFE: it manages the enables of the registers (for writing operations) and the enables of the buffer tri state (for reading operations). There are 2 types of “reading enable” signals: one for the common inputs of the 2 LeCroy units and the other one for the auto clear registers, that must use different signals between the 2 LeCroy units. As a matter of fact, the auto clear registers are duplicated, to allow the auto clear function (see figure 1.4). The auto clear function is implemented with a D-type flip-flop: the registered input (enable) is used to clear the registers one cycle of clock after the reading operation.
- SEL register: it is auto clear, so it is cleared when it is read; it can also be cleared if it is written ‘1’ on the bit 0 of the register 0000 (CLEAR_SEL_1 and CLEAR_SEL_2).

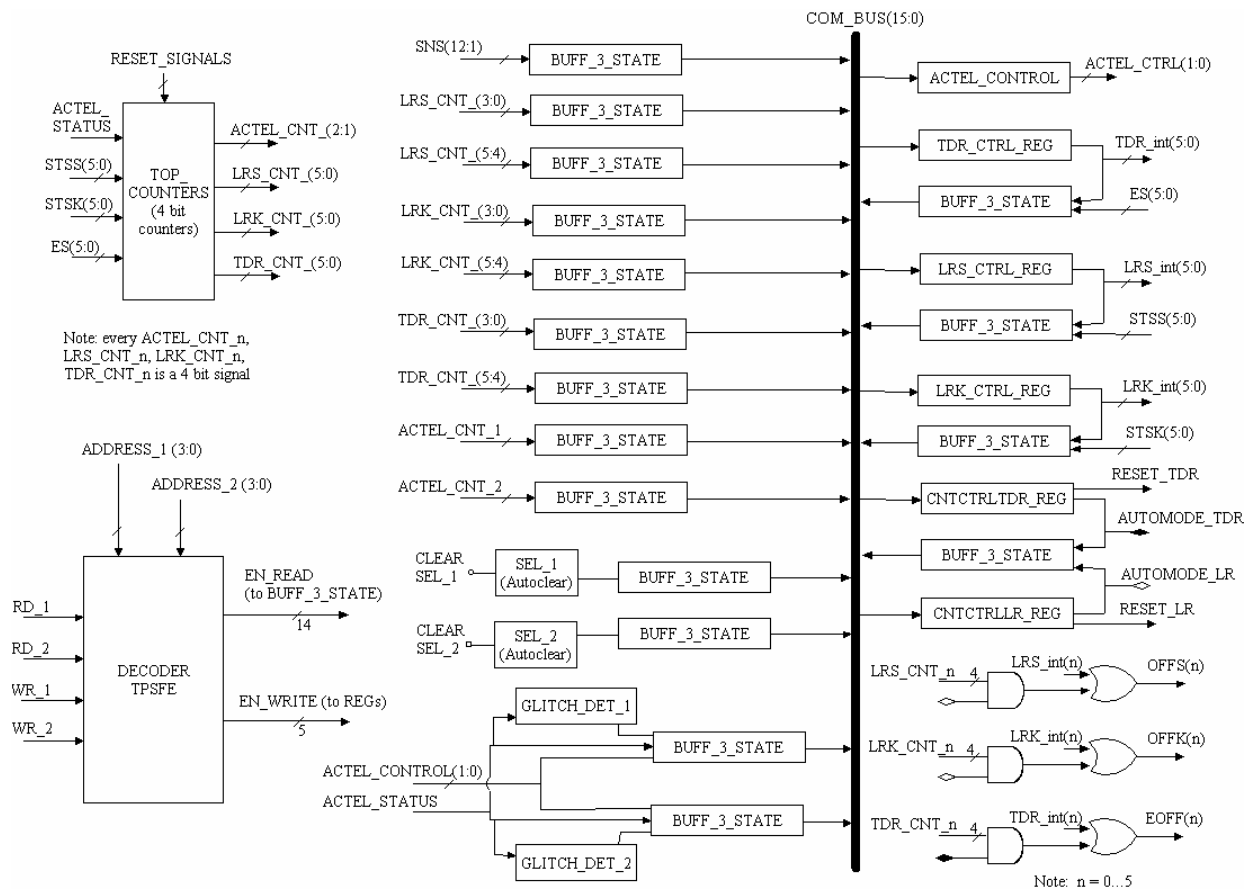

Figure 6

Common bus architecture of the TPSFE

- glitch_det: it is formed by 2 D-type flip-flops, one detecting the falling edge, and the other one detecting the rising edge of the input; the output is the OR of the 2 flip-flops outputs.
- ACTEL_CONTROL: it is a special register with the default value 0002h.
- TOP_COUNTERS: it is a set of counters, as shown in the Fig. 7.
- PRESCALER: it generates a “SCALED_CLK” signal, used for sampling the inputs of the PULSE_CNT blocks. The “SCALED_CLK” samples the input signals at the rising edge, every 32µs.
- PULSE_CNT: it detects every rising edge of the input and increment the 4-bit counter. When the counter reaches “1111”, it stays in that state. There is a clear signal to reset the counters. The ACTEL_STATUS counters are autoclear, while the others get the CLR signal respectively from registers “0111” and “1000”.

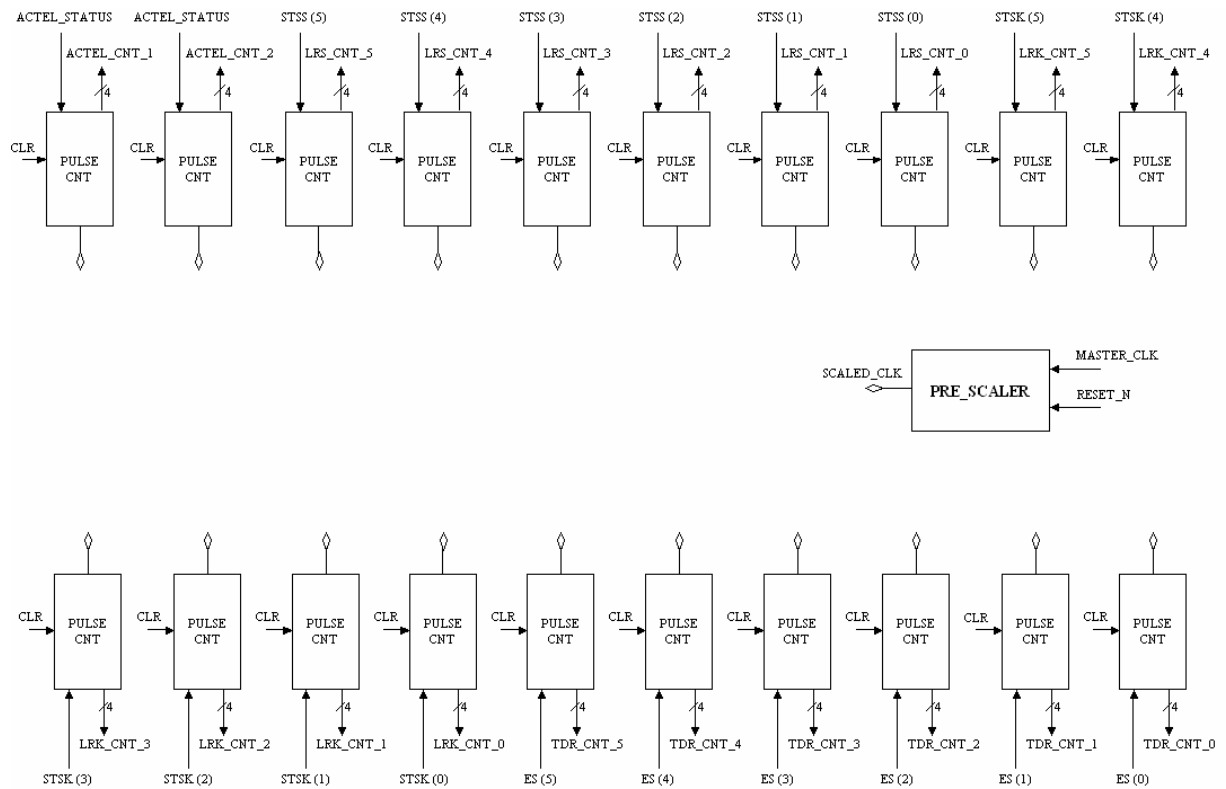

Figure 7
TOP_COUNTERS architecture of the TPSFE