

A. Lebedev
MIT

***DAQ System
Design
and
Commanding***

AMS TIM Meeting, July 2004, Geneva

AMS-2 DAQ Overview

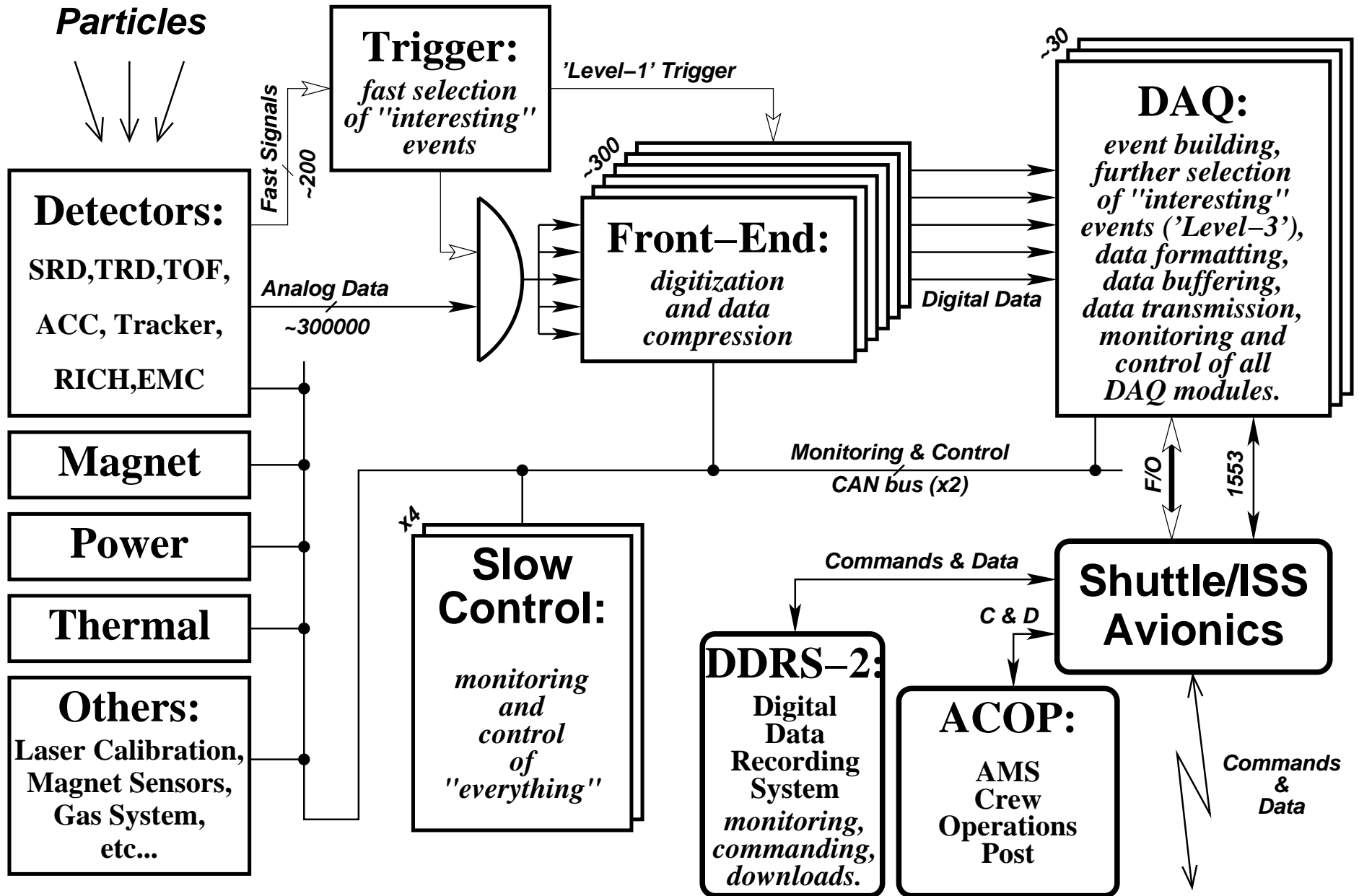

DAQ System Structure (1)

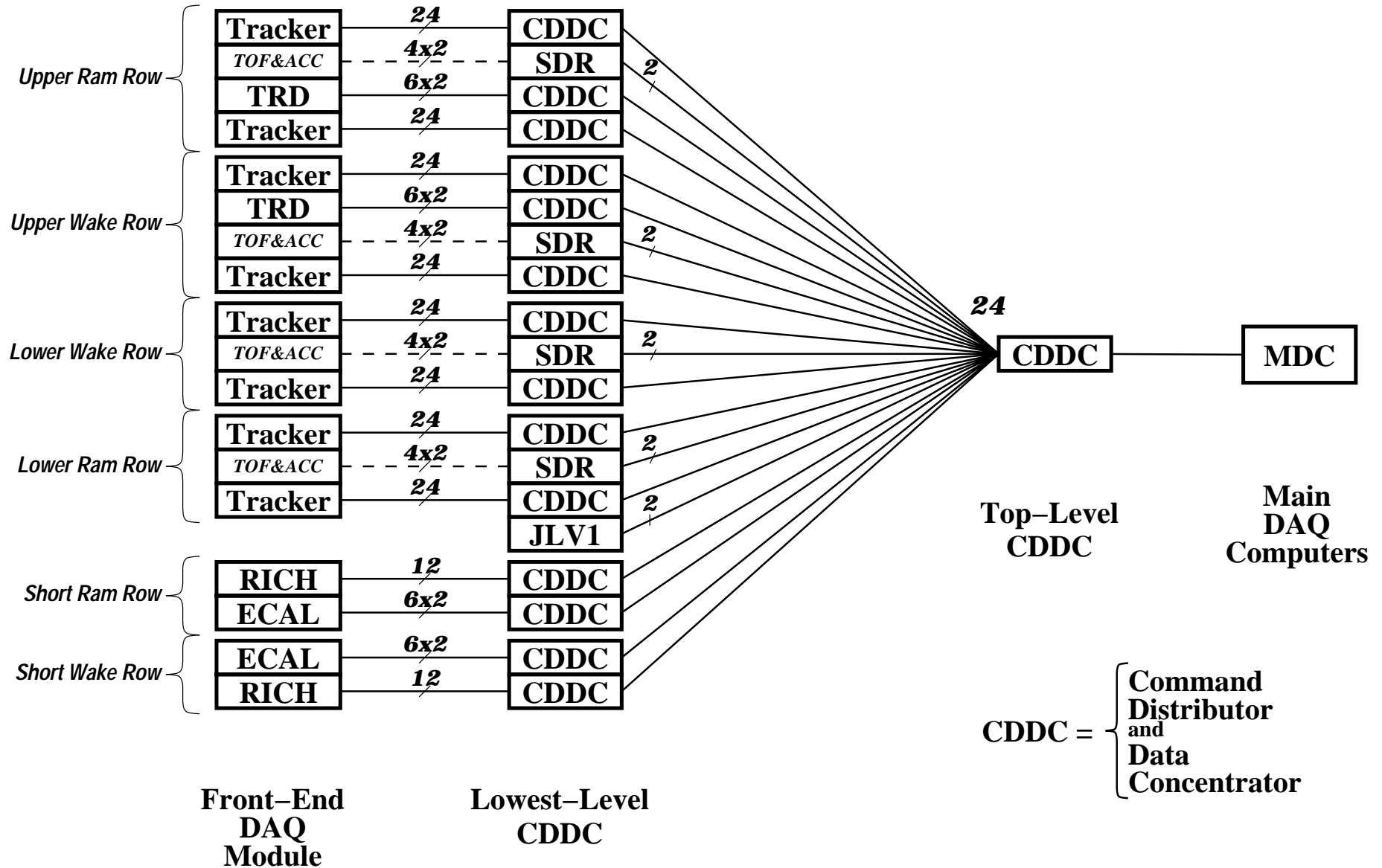

DAQ System Structure (2)

Redundancy:

- Front-End DAQ Modules: 1 (2 for TRD, TOF, LV1)
- Front-End CDDC:..... 2
- Top-Level CDDC:..... 4
- Main DAQ Computers:... 4

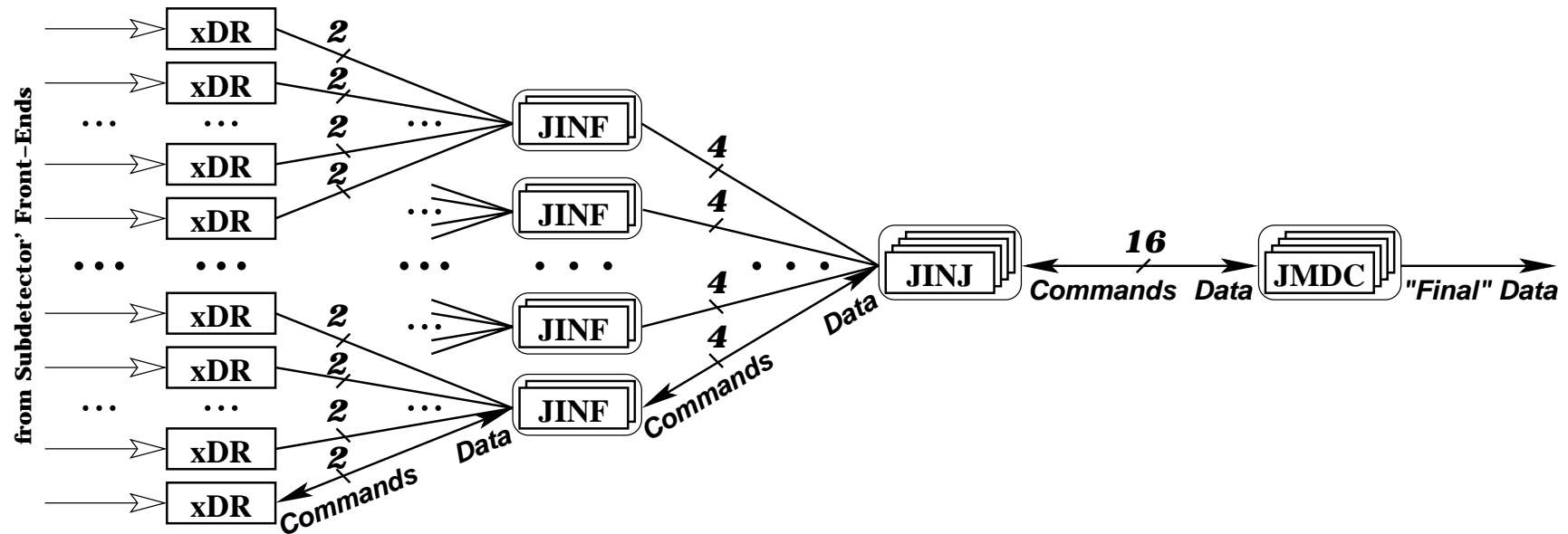

284? x 1(2)
Front-End
DAQ
Modules

14 x 2
Lowest-Level
CDDC,
4 x 2 SDR,
1 x 2 JLV1

1 x 4
Top-Level
CDDC

1 x 4
Main
DAQ
Computers

DAQ System Structure (3)

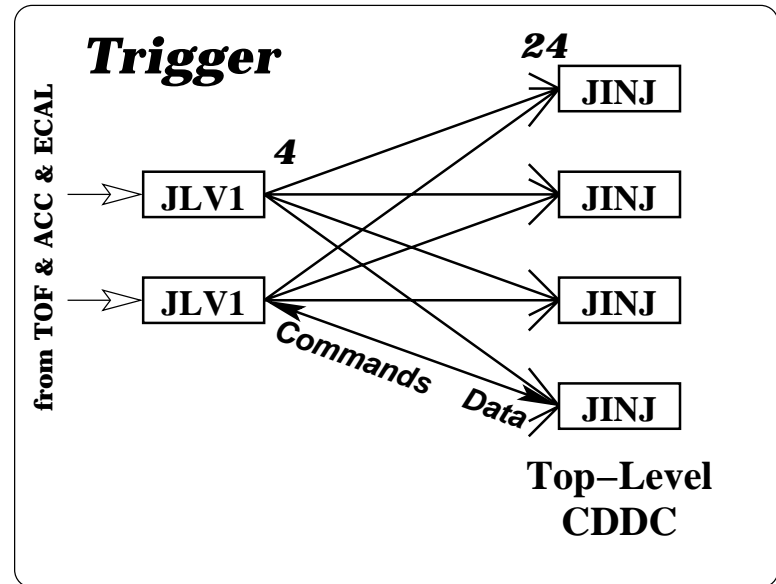
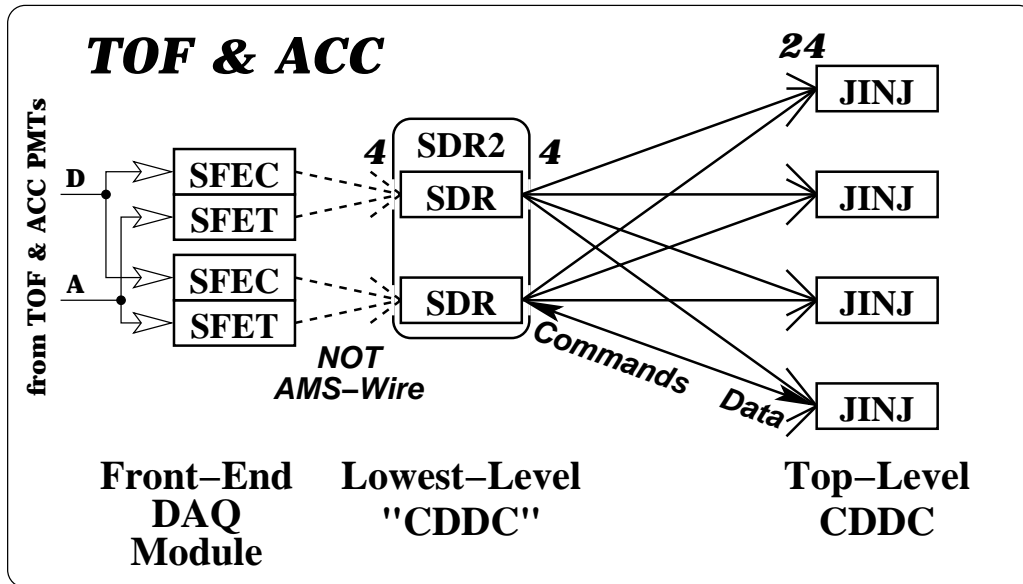
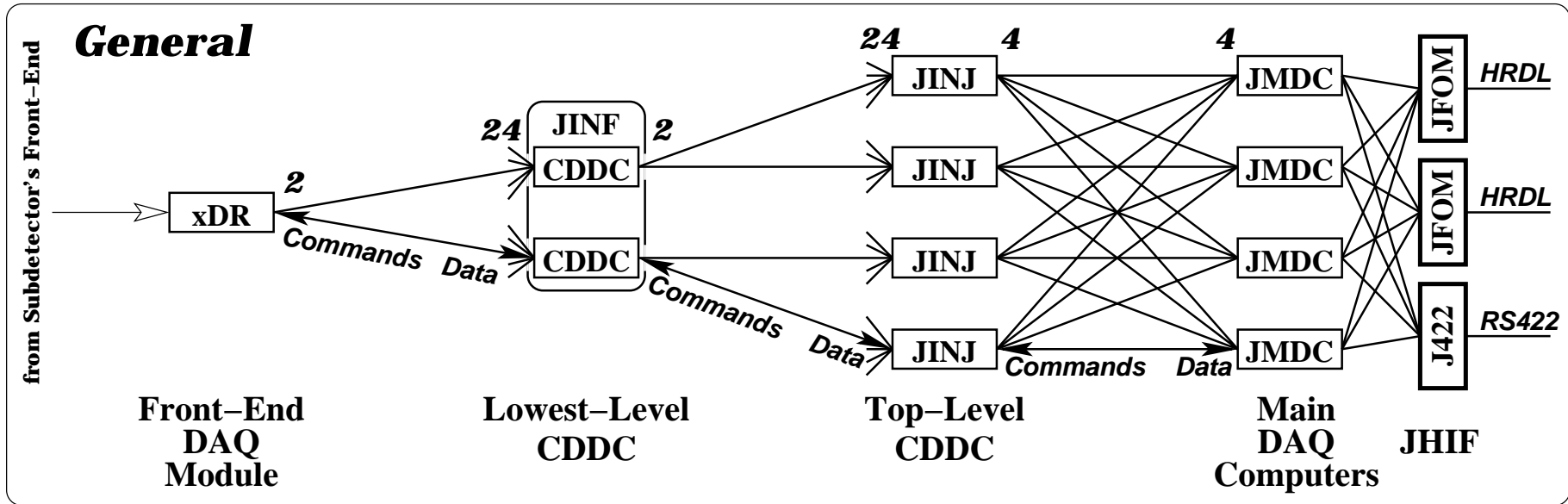

JMDC Interfaces

Top-Level CDDC

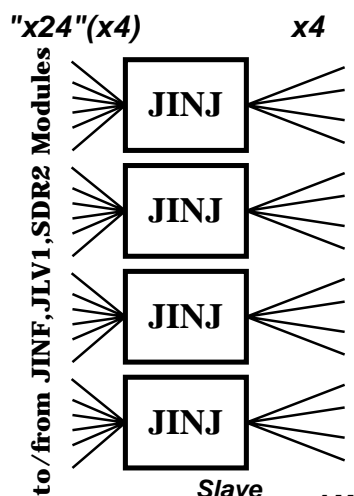

Top DAQ Modules in J-Crate

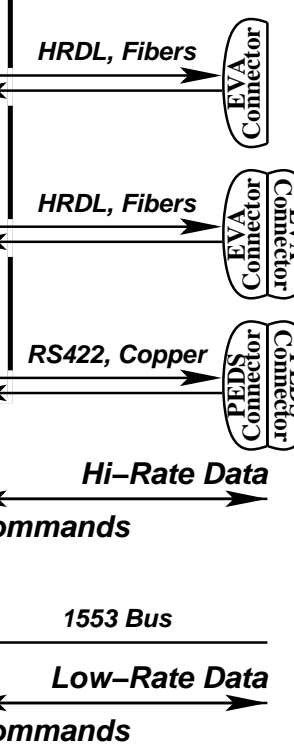
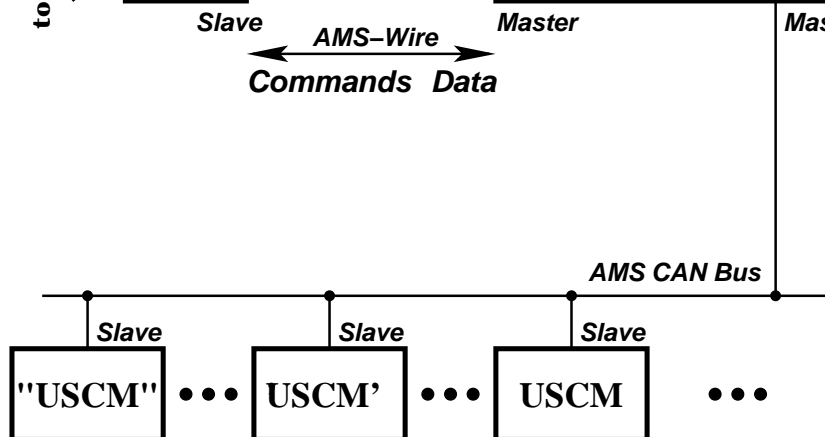
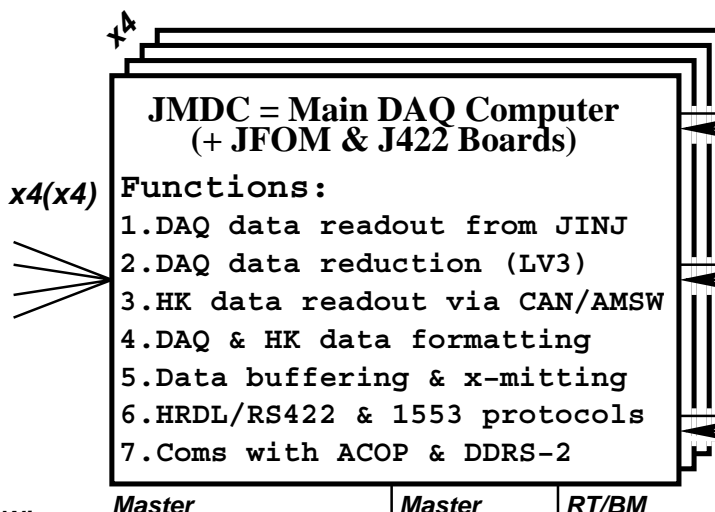

ISS Avionics

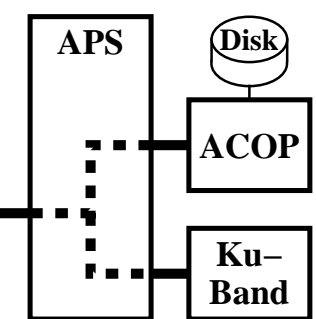

STS Avionics

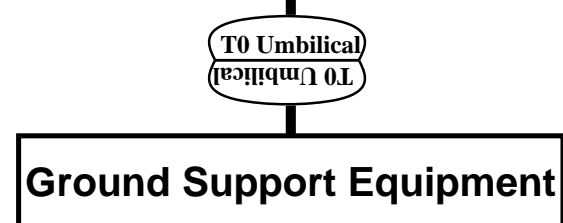
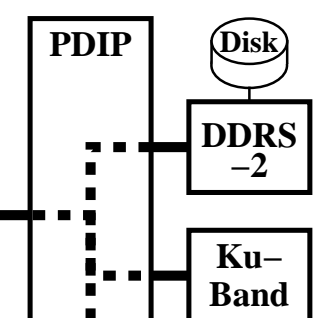

Note 1. DAQ data are read without external interrupt.
 Note 2. AMS-Wire interface between JMDCs not shown.
 Note 3. CAN Bus interface between JMDCs not shown.

ACOP – AMS Links

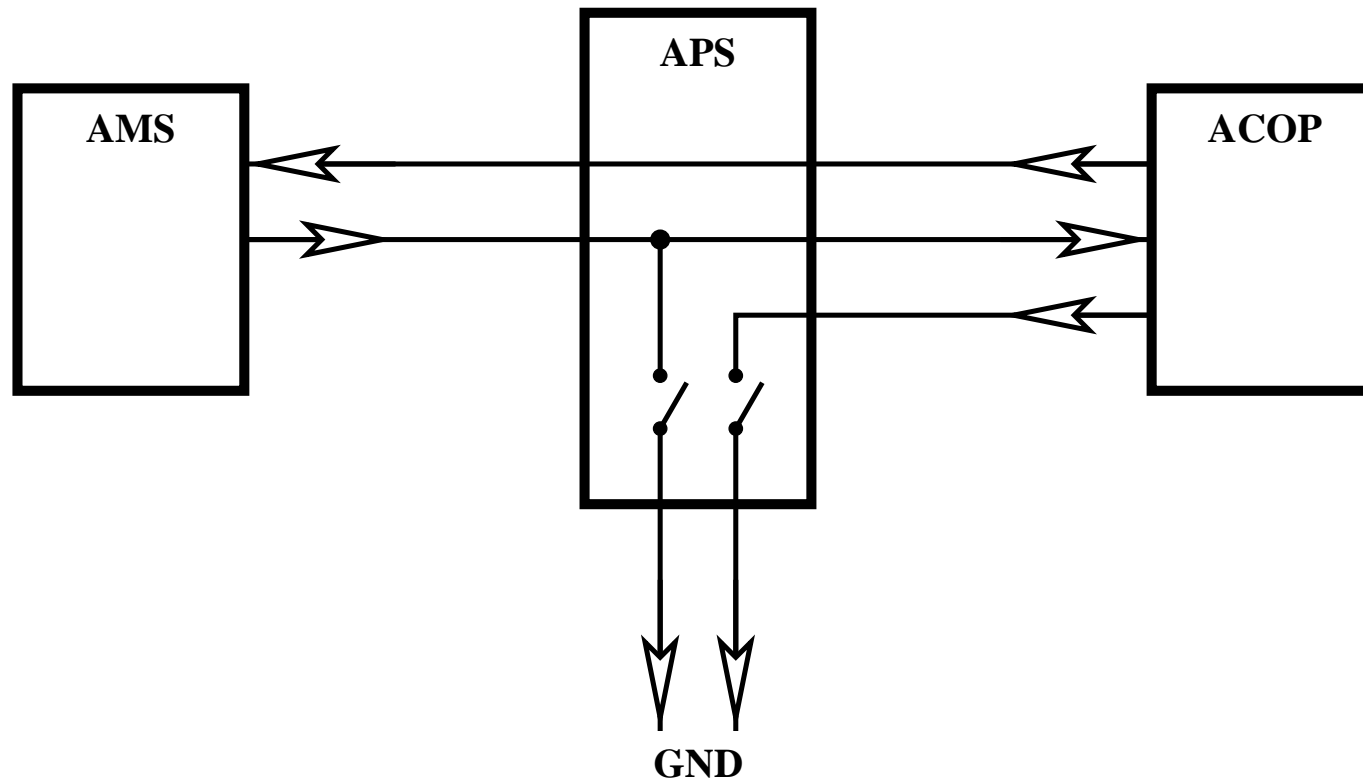

JMDC Functions

DAQ Data:

1. Read DAQ data from JINF(s) via AMS-Wire (send command, get event).
2. Do DAQ data reduction (Level-3 Trigger, compression).
3. Reformat DAQ and H/K data (framing to NASA standards).
4. Buffer DAQ and H/K data (1-2 orbits, 1.5-3 hours, 1.5-3 GB).
5. Transmit DAQ and H/K data to STS via RS422 or to ISS via HRDL.

1553, HRDL, RS422 command interface:

1. Receive command:
 - from STS/ISS/T0 via 1553,
 - from ACOP via HRDL,
 - from DDRS-2/T0 via RS422.
2. Analyse command:
 - if to this JMDC then execute command;
 - if to other DAQ or H/K module(s) then reroute command;
3. Send reply to command source.

AMS Houskeeping/Slow Control:

1. Send commands periodically ("file q") to H/K modules via CAN bus or AMS-Wire.
2. Receive H/K data from H/K modules via CAN bus or AMS-Wire.
3. Transmit H/K data to STS via RS422 or to ISS via HRDL.
4. Configuration/Parameter Files to keep "file q" and other things.
5. Subdetector and subsystems calibration, control and monitoring.

AMS-2 Commanding during Integration and Ground Tests

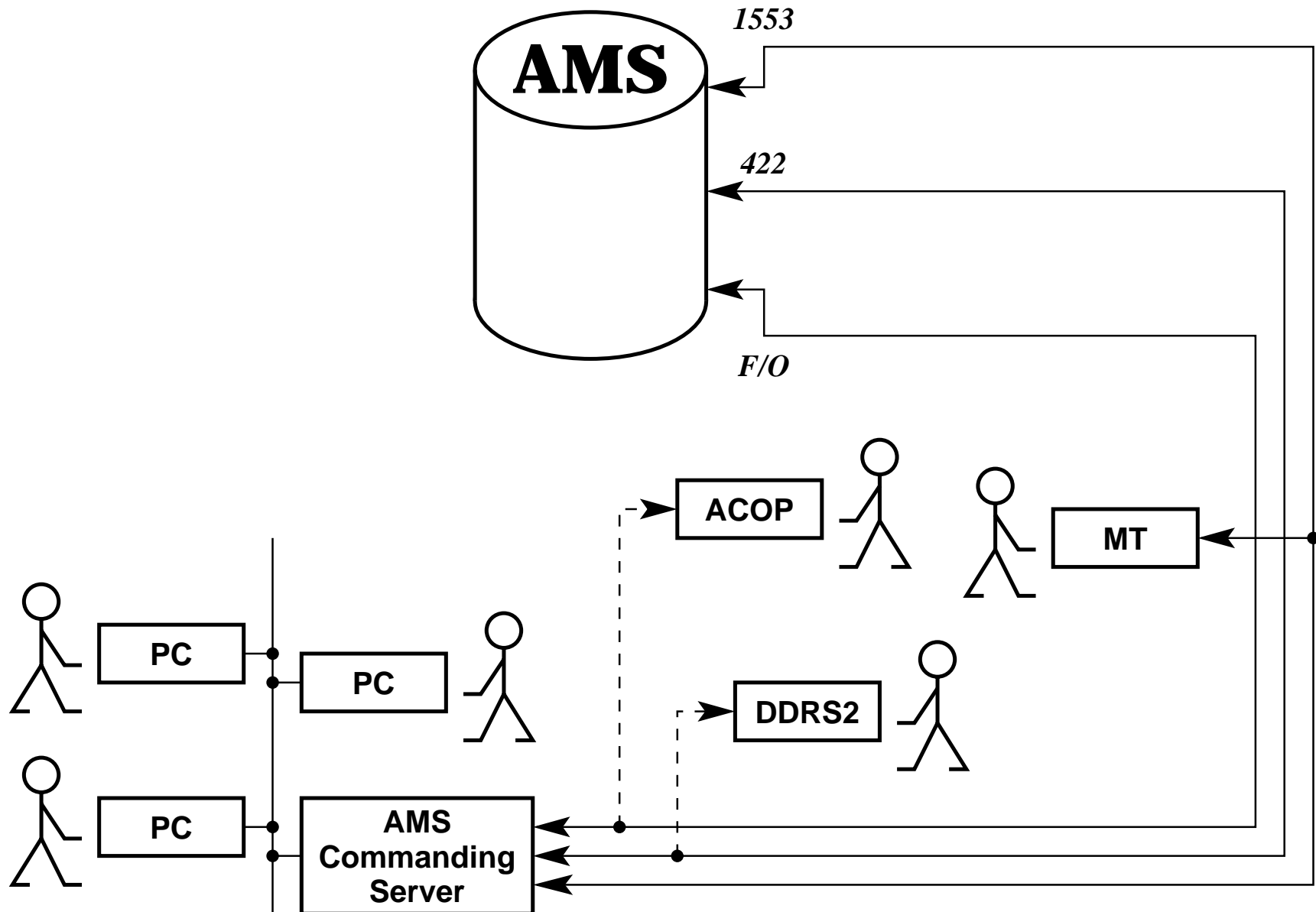

AMS-2 Commanding on the Launch Pad

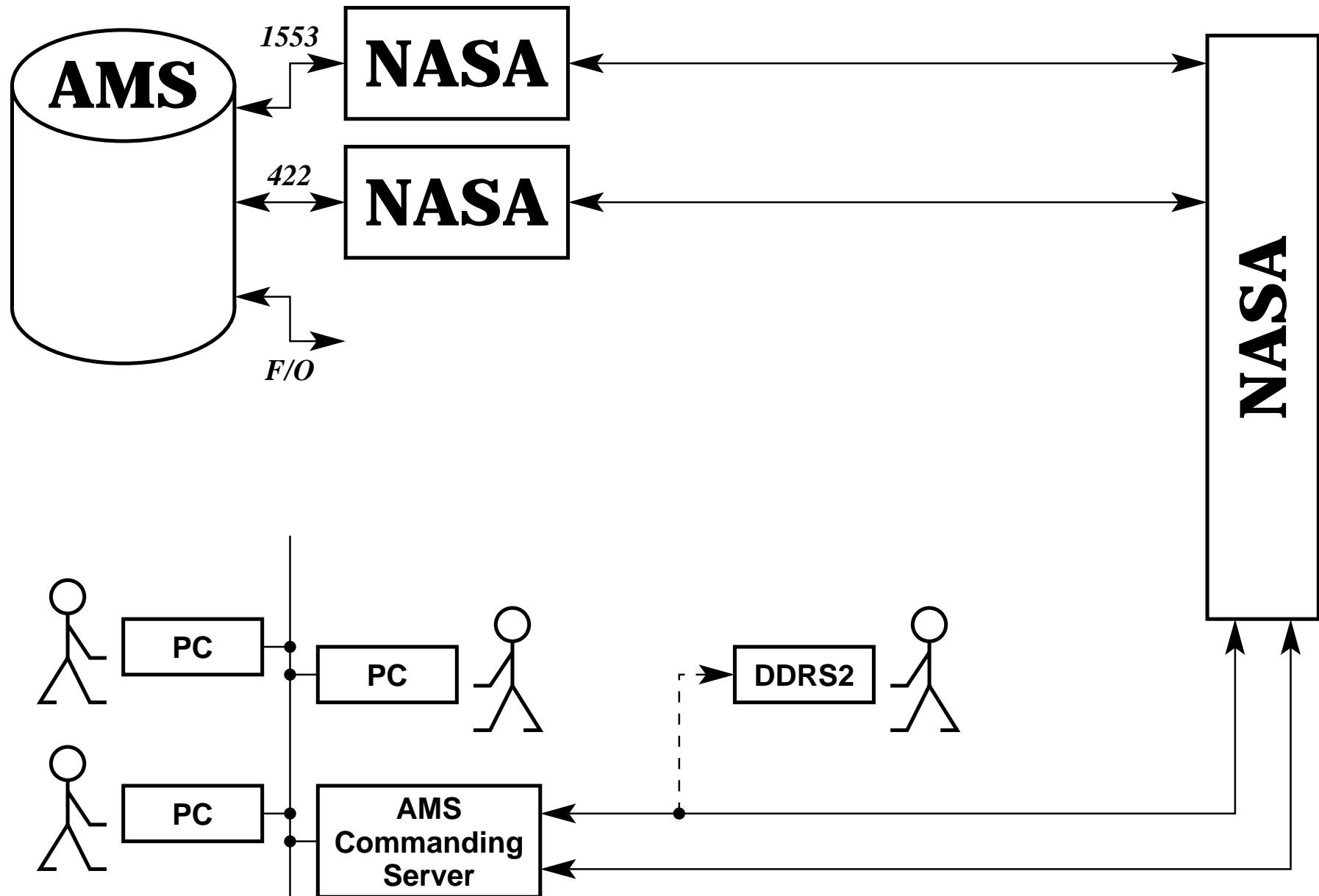

AMS-2 Commanding in Space

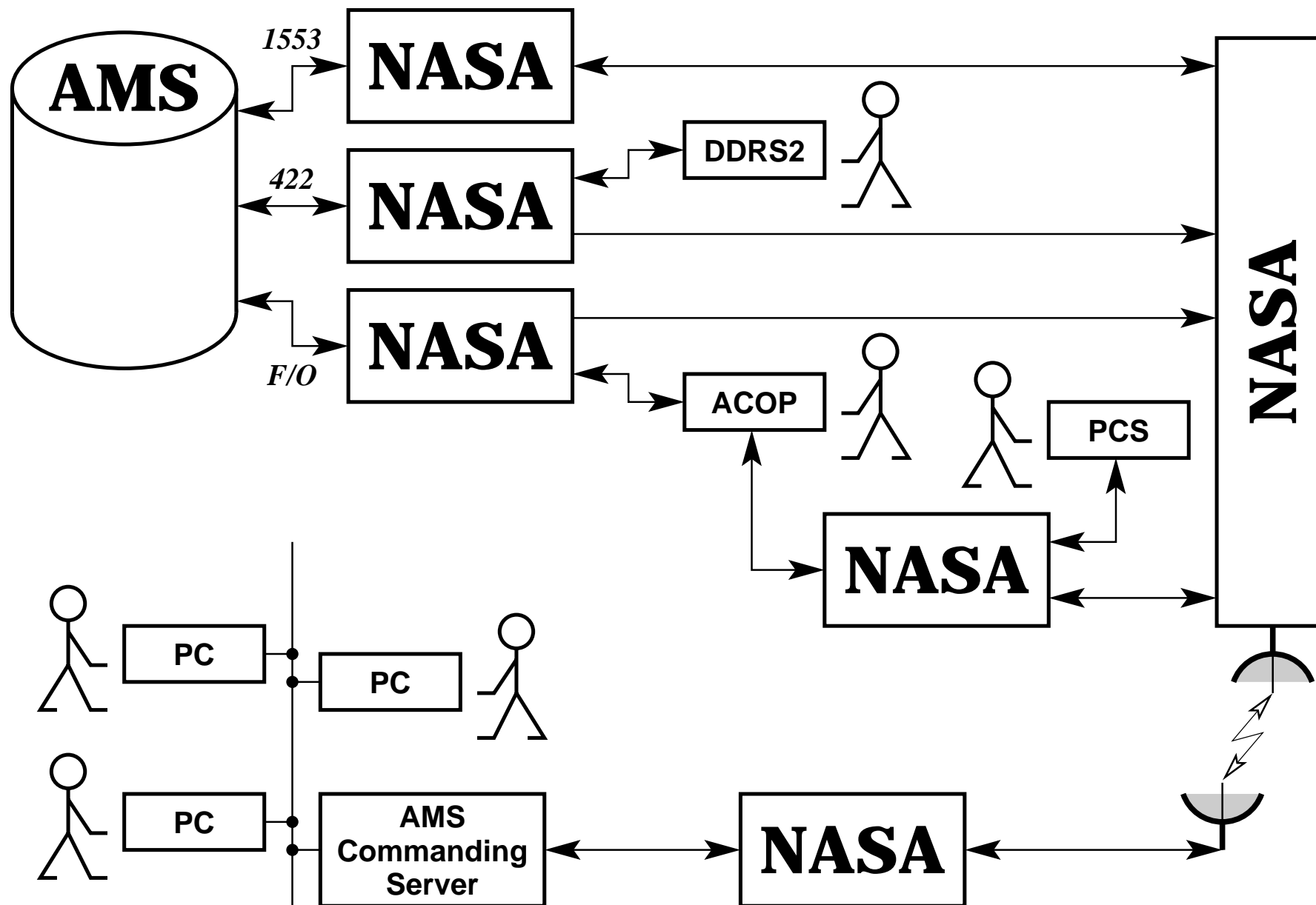

Slow Control Architecture Overview

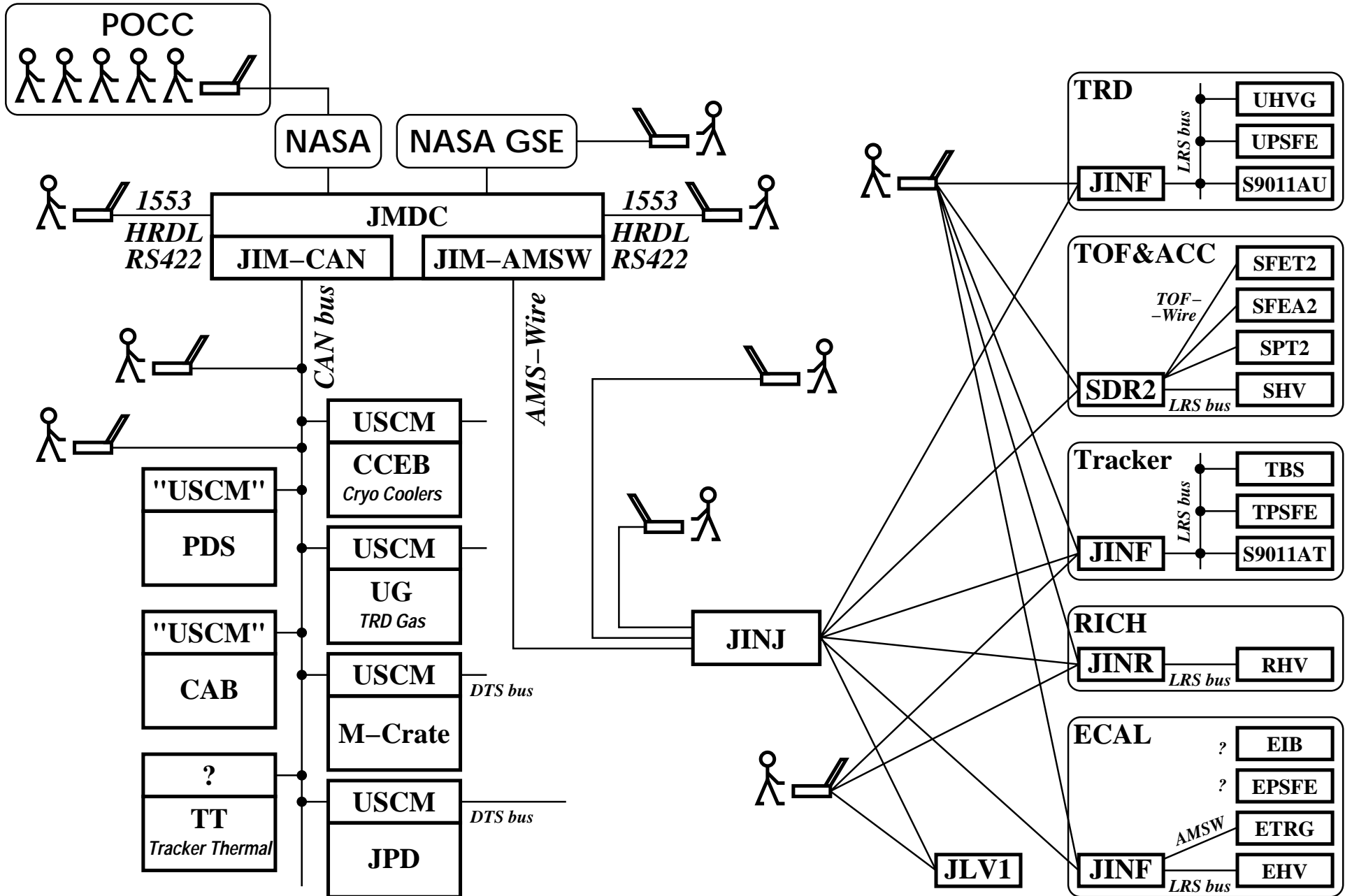

USCM

JMDC

0x31

2

UGBS Commander & Monitor

Board	Clock Line	Data Line	INIT
00	0000 0001	0000 0000 0000 0001	

Valve	Enable		Time, s	Cmnd	Status	
	S	C			S	C
V1a	E	D	12.000	OPEN	O	1
V2a	E	E	0.100	OPEN	C	1
V3a	D	D	34.000	OPEN	C	0
V4a	D	D	1.230	OPEN	C	0
V5	D	D	0.000	OPEN	C	0
V10a	D	D	0.000	OPEN	C	0
V20a	D	D	0.000	OPEN	C	0
V1b	E	E	3.210	OPEN	O	1
V2b	D	D	0.000	OPEN	C	0
V3b	D	D	0.000	OPEN	C	0
V4b	D	D	0.000	OPEN	C	0
V10b	D	D	0.000	OPEN	C	0
V20b	E	E	0.000	OPEN	O	1
V20a&V20b	?	?	0.000	OPEN	?	?
	W	R			R	R

Regulators					
5V	D	W	E	R	
24V	E		E	R	

Sensor	Value	
P1a	17.4	R
T1a	52.9	R
P1b	17.0	R
T1b	22.4	R
P2a	12.3	R
T2a	11.8	R
P2b	36.4	R
T2b	53.0	R

Period, s 2 MON

Command executed O.K.

P
0

