

TTCS tube routing proposal

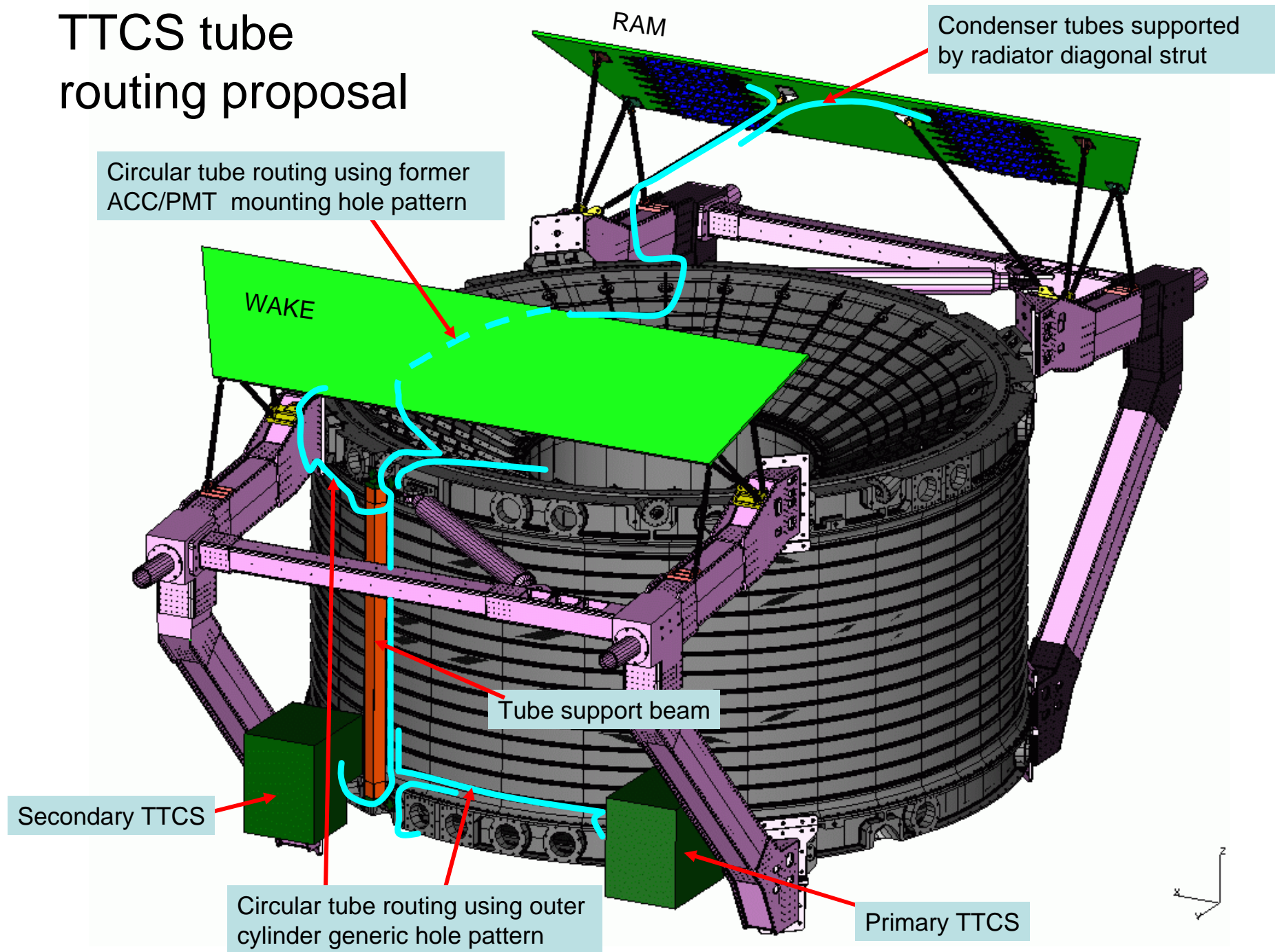

TTCS tube support beam for Z-directional tube routing

Beam mounting using GSE holes of cold mass strap installation tool

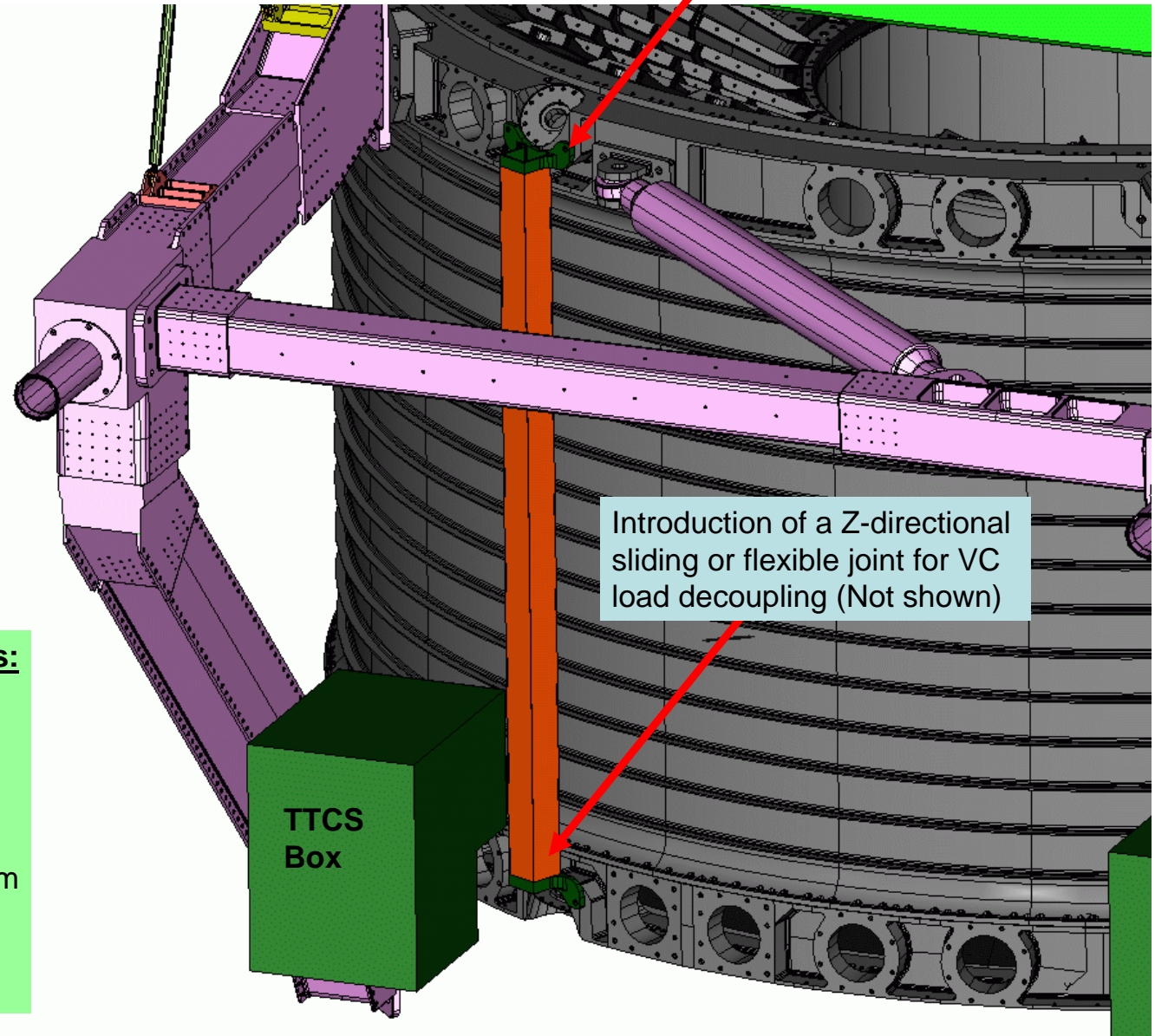

Tube Support Beam Properties:

- Square tube: 60x60x2mm,
- Length: 1.3mm
- Material: AA6061
- Beam assembly mass: 2 kg
- 1st resonance frequency: 62 Hz
- Displacement under 40g: 2.6mm
- Tube and fastener load: 2.3 kg
- MS (Ultimate): 2.6
- MS (Yield): 3.3

TTCS Tube Layout

(fold- and roll-out drawing)

