

TRD-GAS Electronics

- Status UG Crate Electronics B. Borgia
- From here to TRD-GAS Flight Electronics

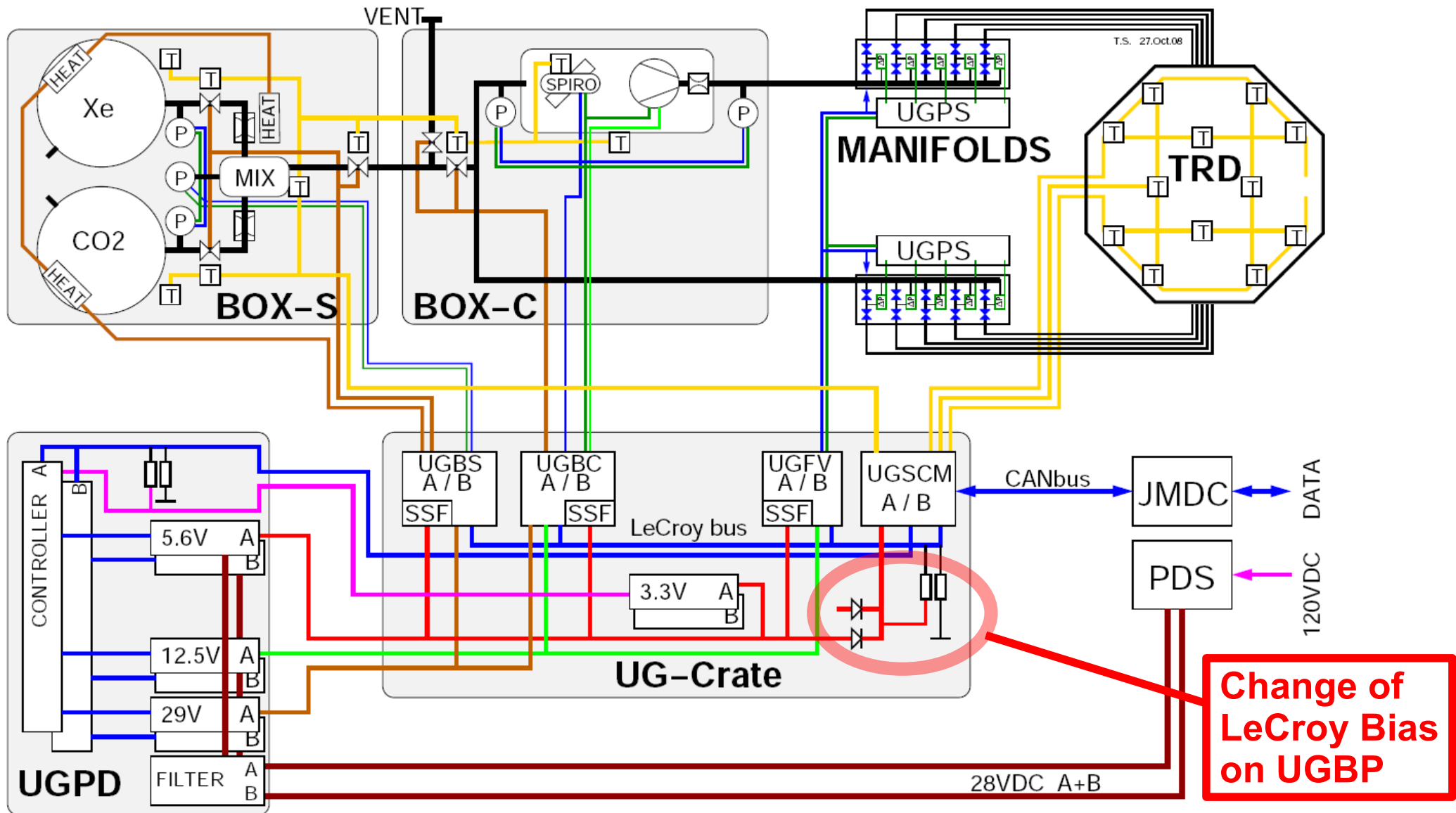

Available TRD-GAS Electronics

QM2 UG-Crate - UGBP with LeCroy pull-up modifications
2xUGSCM 2xUGBS 2xUGBC 2xUGFV
QM2 UGPD

Reference Setup
at CERN

FS UG-Crate - 2xUGSCM **1xUGBS** **1xUGBC** 2xUGFV
UGBP modified and ESS tested
LeCroy Cable to be changed
FM UGPD

Flight Electronics
Option 1

FM UG-Crate - 2xUGSCM 2xUGBS 2xUGBC 2xUGFV
ESS done with unmodified UGBP
UGBP to be modified
LeCroy Cable to be changed

Flight Electronics
Option 2

Functionality with flight TRD-GAS system has been verified - Reliability needs evaluation

Action list for acceptable TRD-GAS flight electronics approved by AMS electronics group

- 1) Specify support needed from UG group for assessment e.g. at reference setup
- 2) Actions for Options 1, 2, (3...) Reassembly/Modifications & Tests (Functionality/ESS)
- 3) UG group to schedule remaining work for acceptable options
- 4) (Formal) meeting to choose TRD-GAS flight electronics option