

AMS 02 RADIATOR MASS REDUCTION

HANDOUT

Reference Pictures

Names

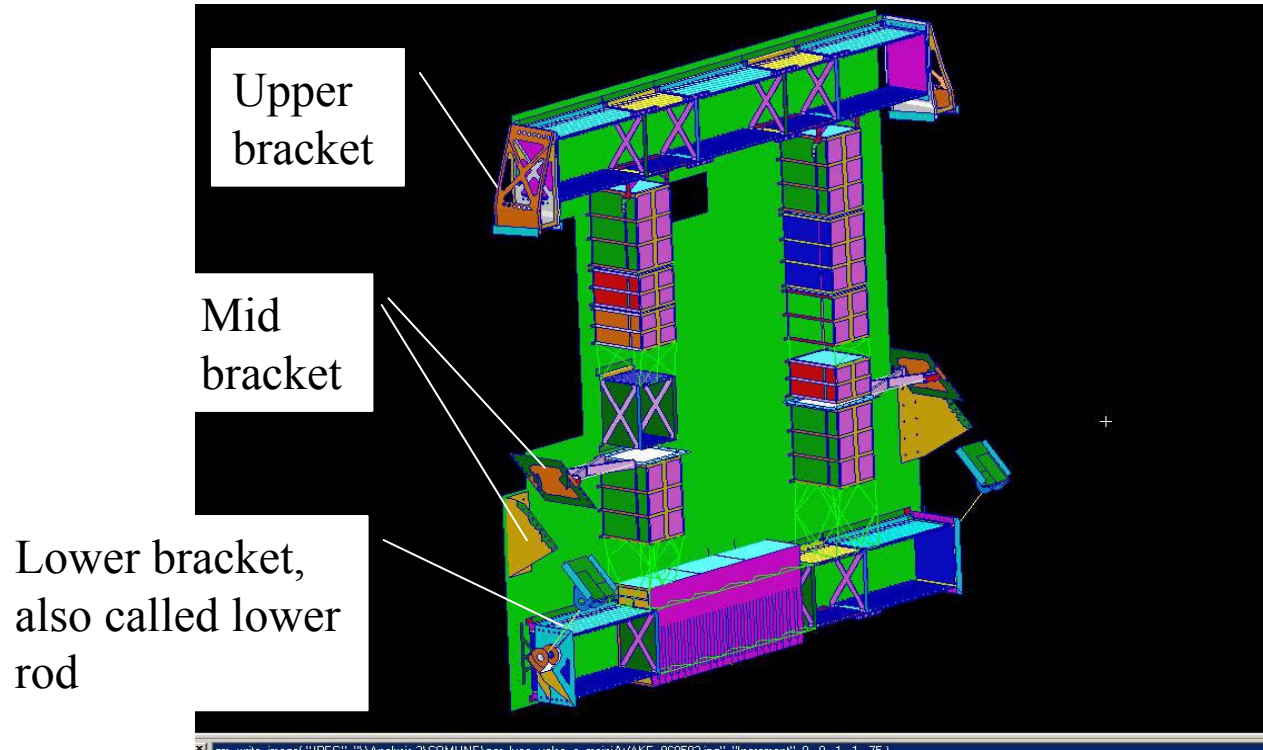

“Heavy” upper bracket

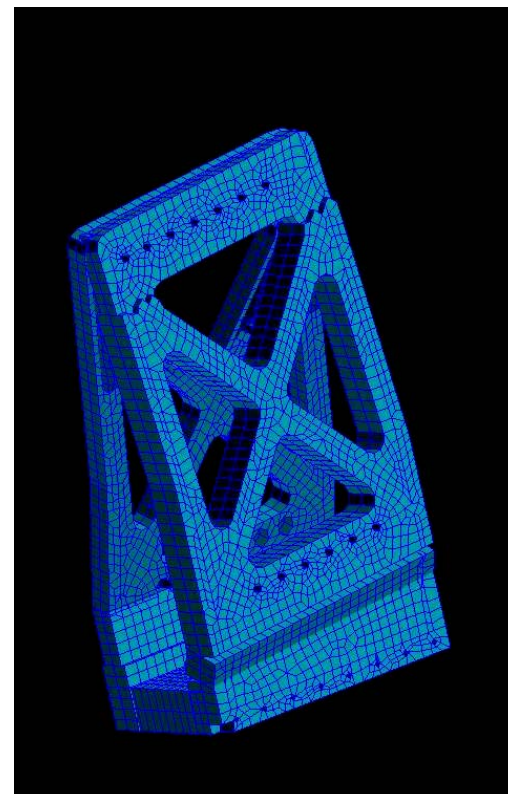
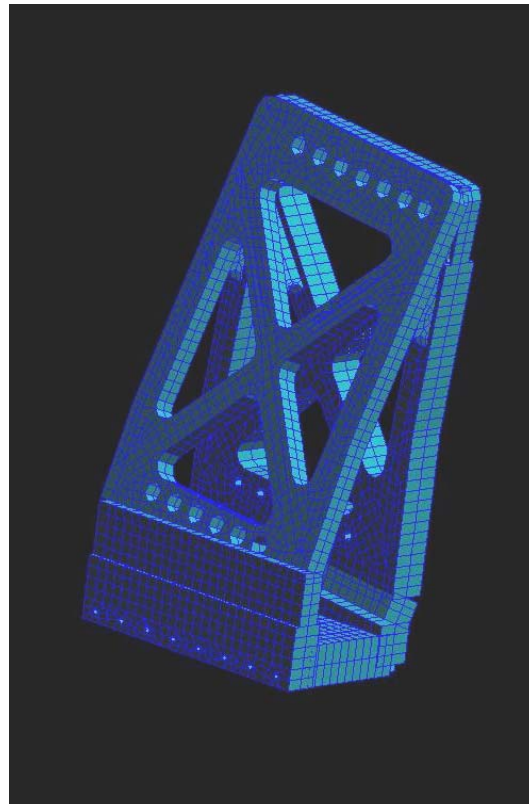

“Light” Upper bracket

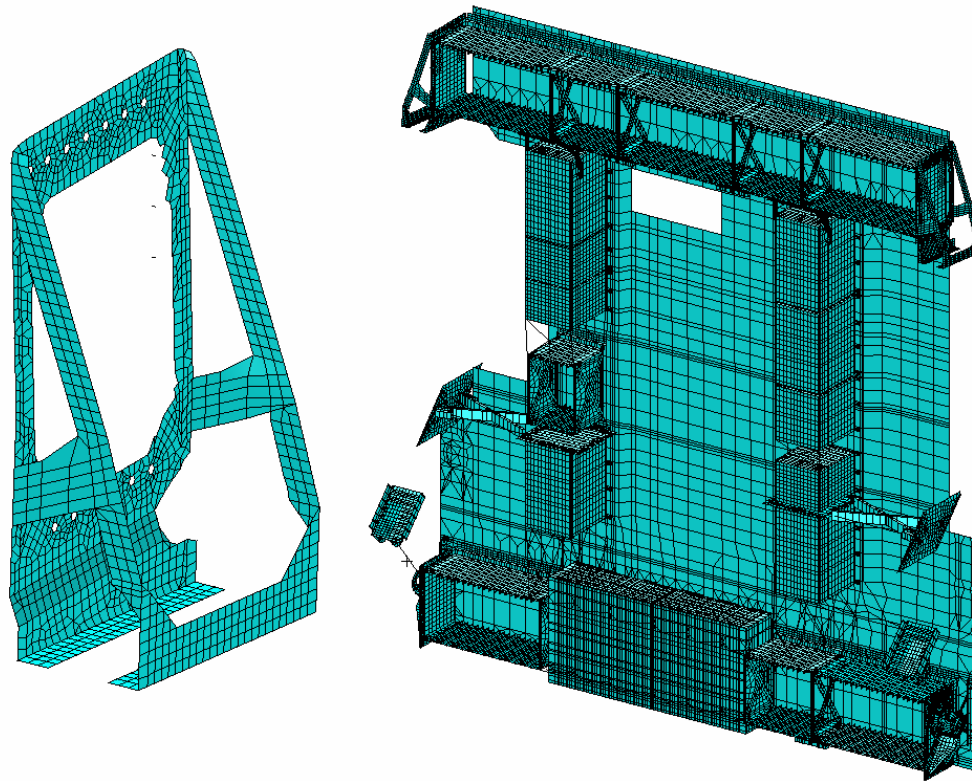

Dumbbell upper bracket

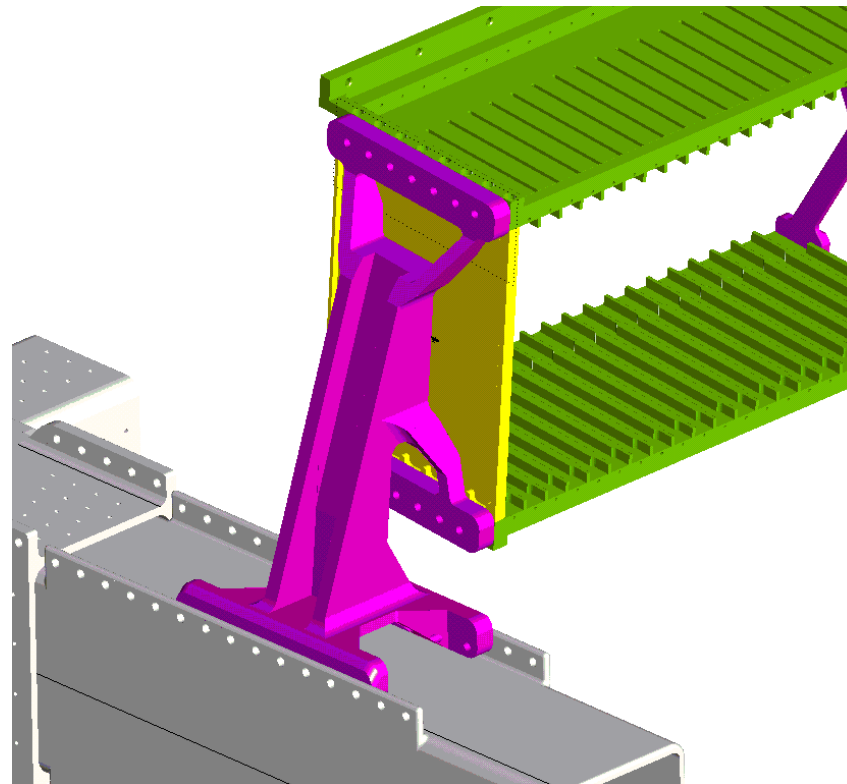

Mid bracket

- XY Bracket

Z bracket

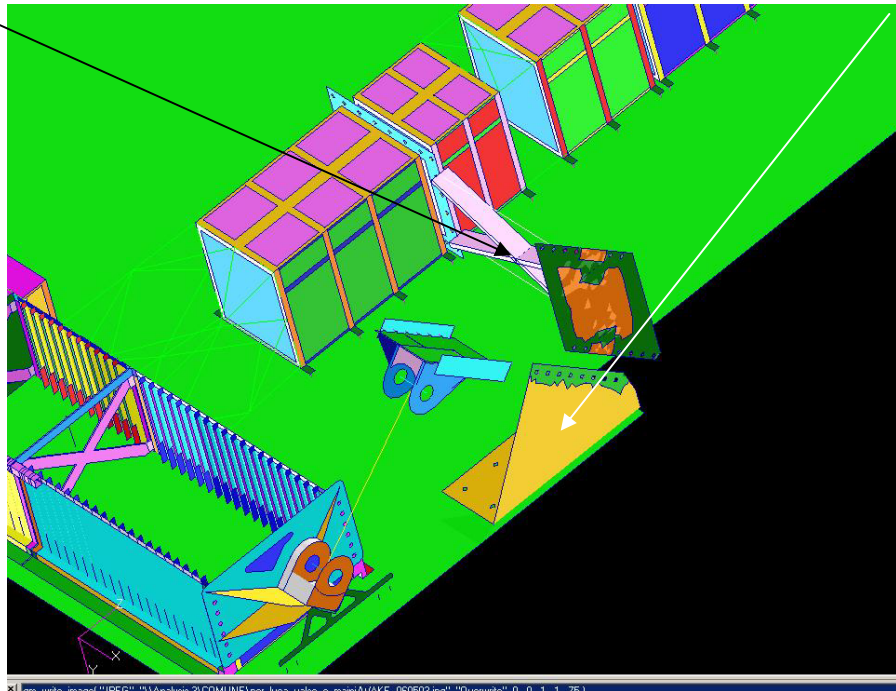

Lighter Mid bracket

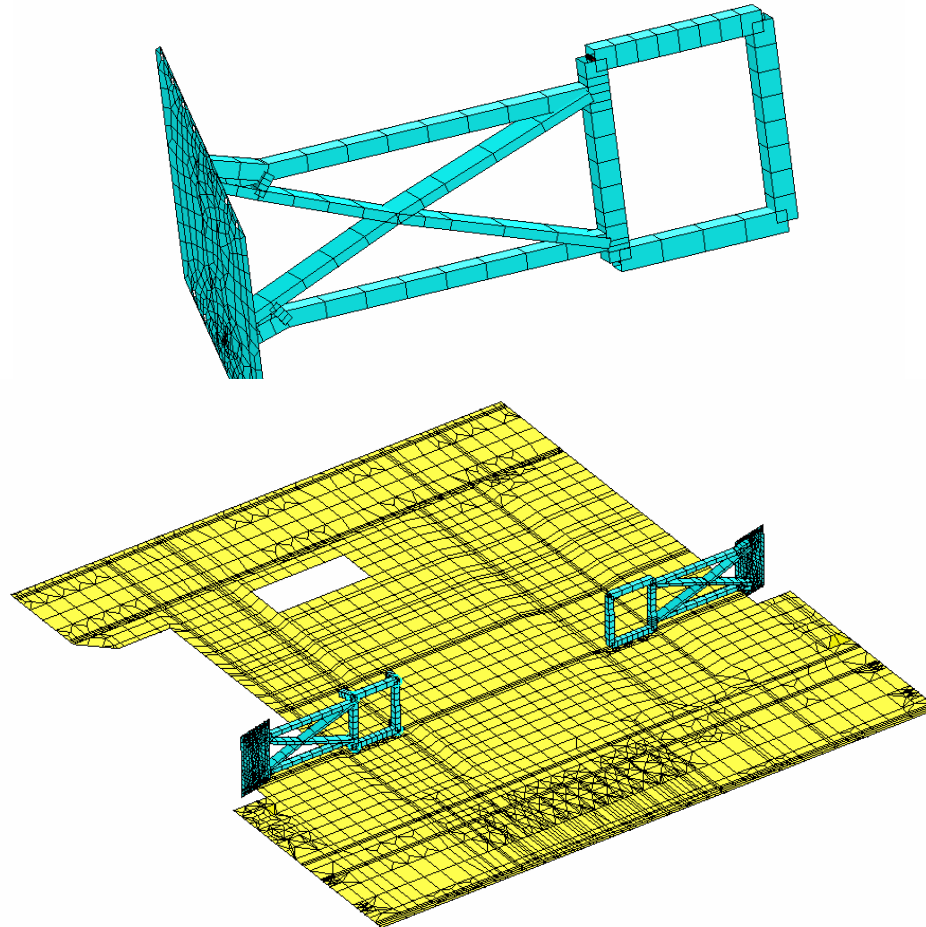

RAM radiator MID BRACKET

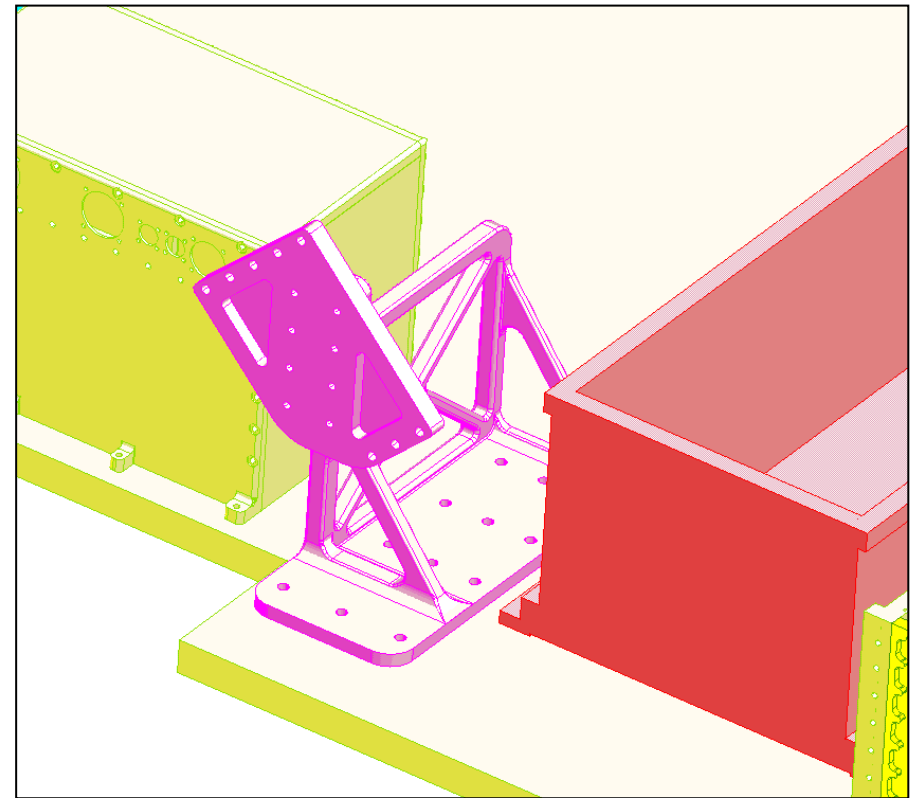
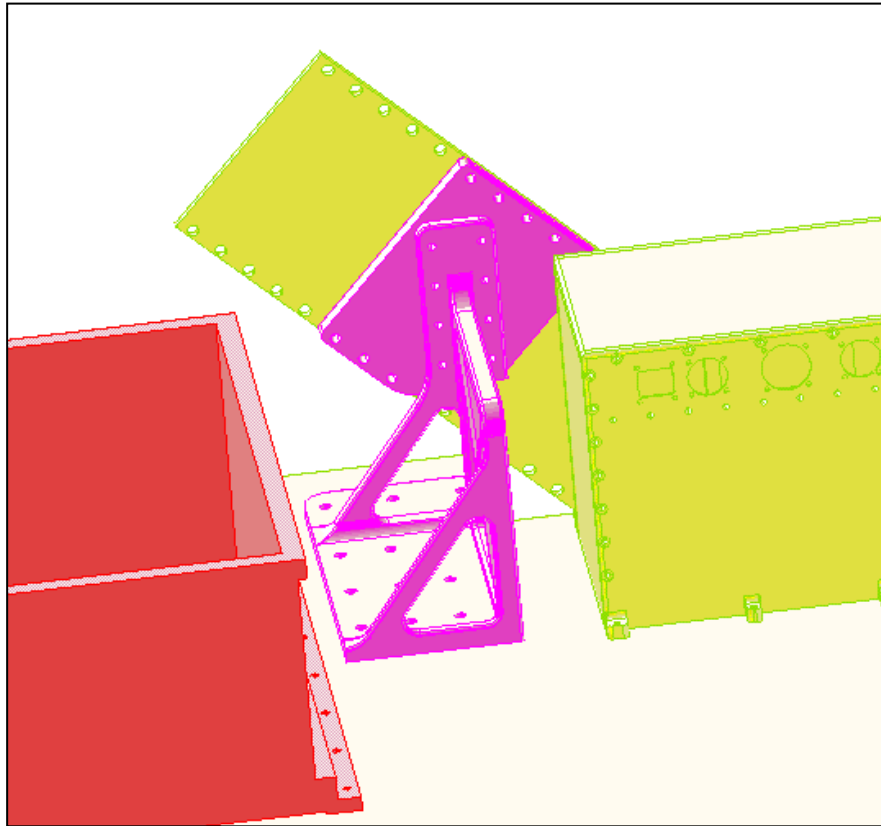

Mid bracket 'tube' configuration

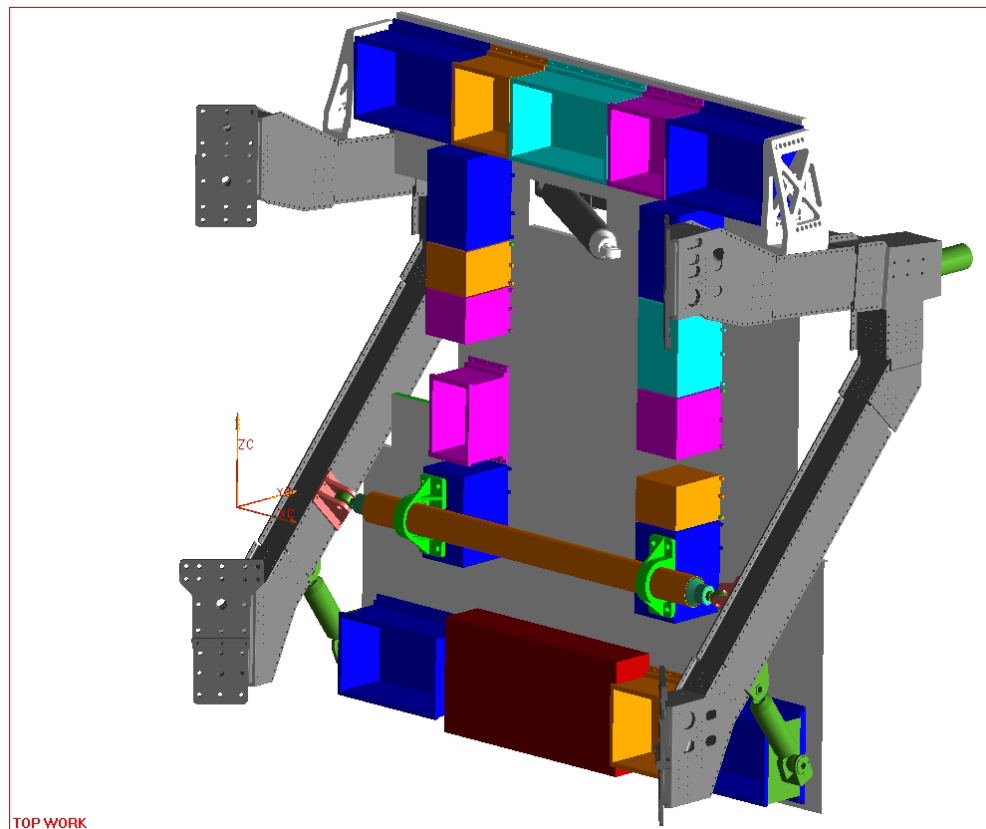

Lower bracket assembly

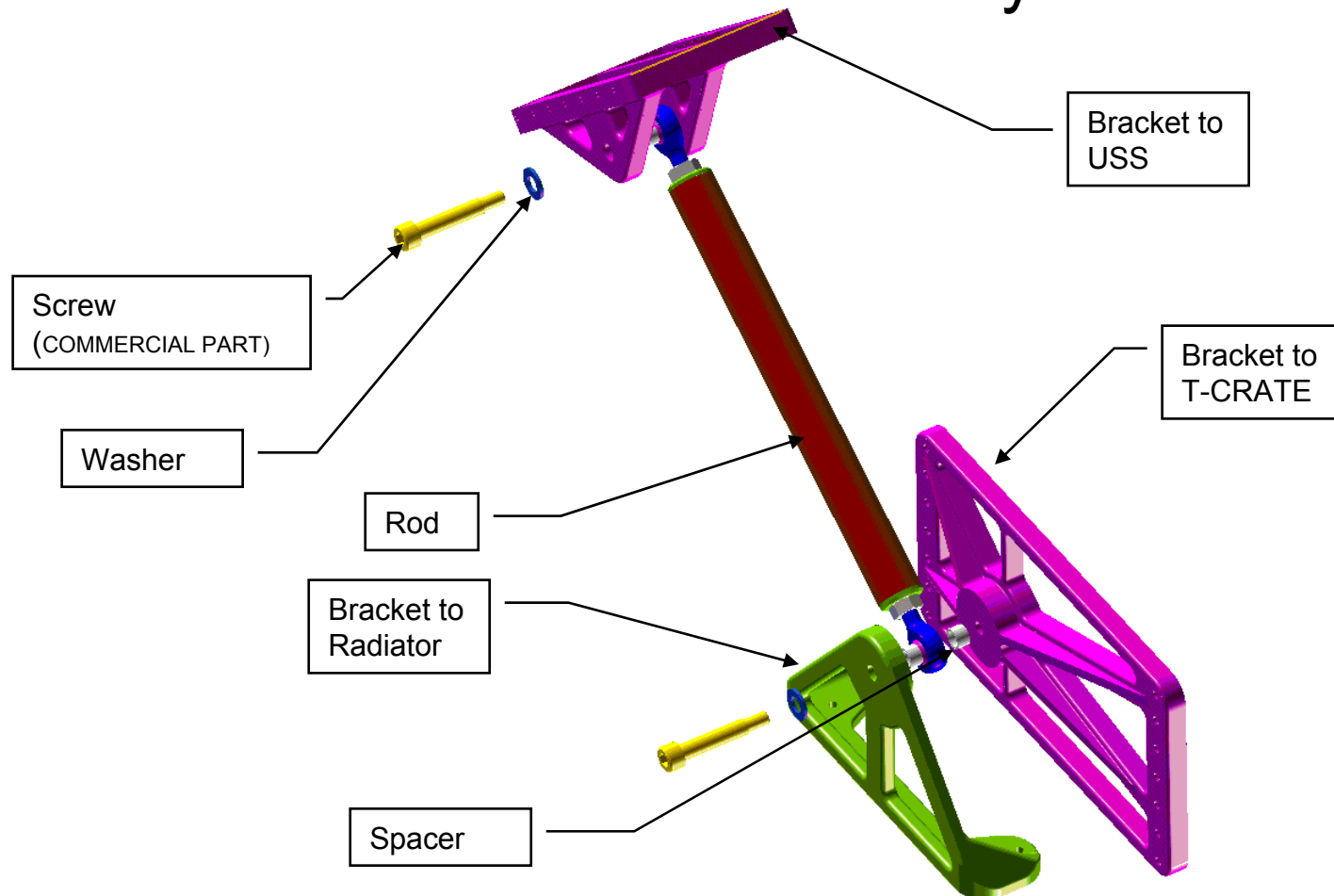

LOWER BRACKET OPTION 2

Removal of crate end wall

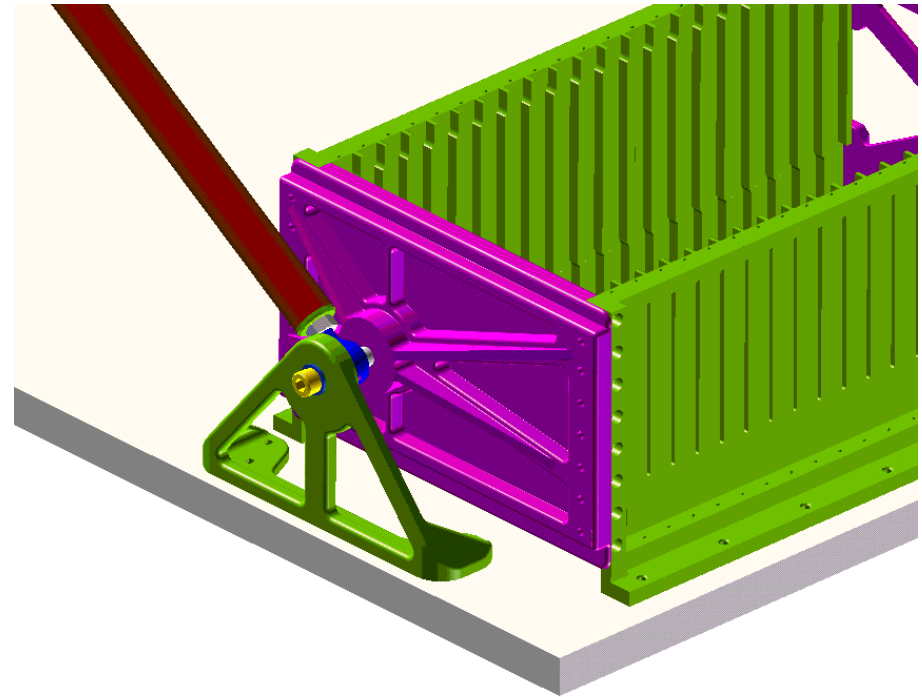
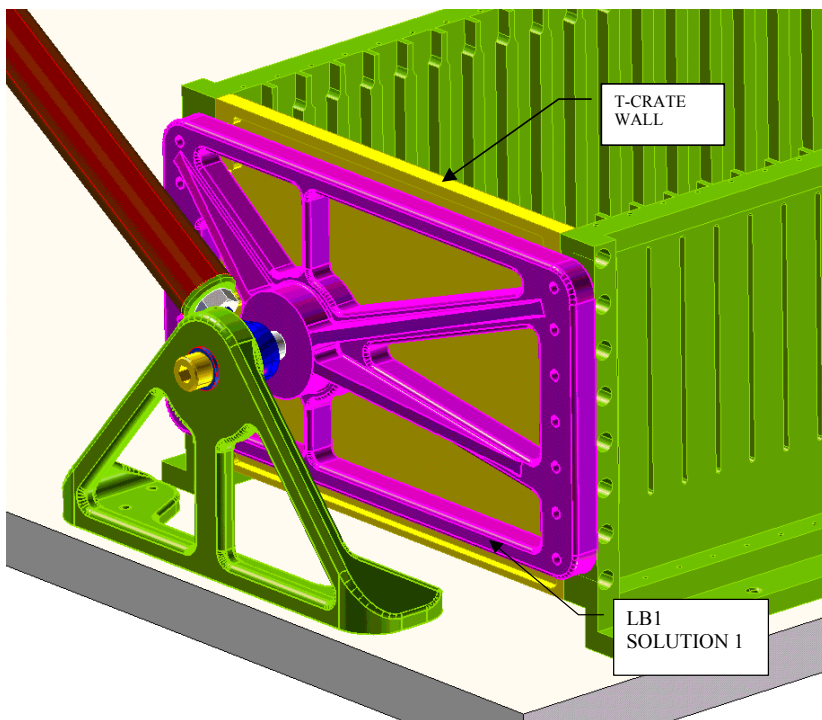

Lower bracket - plate

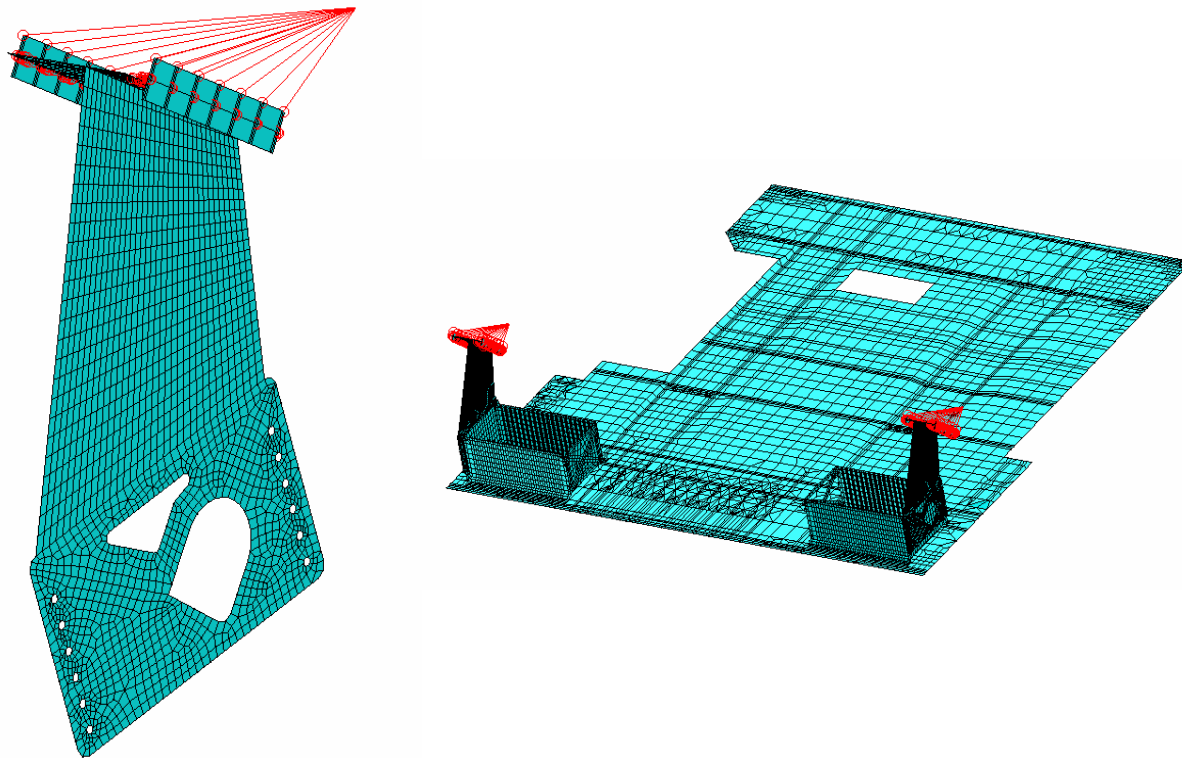

RAM radiator: “squared” crates layout (no more gemini)

