

AMS 02 RADIATOR MASS REDUCTION THERMAL

Alberto Franzoso

Crates walls thickness reduction

Simulation configuration

- Radiator temperature at 50°C (as per ICD)
- Steady state solution (no orbital evolution)
- Thermal model correlated after NSPO test campaign.
- Dissipation budget as per M. Capell Flight Design, July 2003 (last official release).

Remarks

- When no thickness reduction was possible, a new card disposition was checked to avoid power concentrations (hot spots)
- Electronic people feedback needed
- **Mass savings ARE NOT BASED on CAD: they are just estimations to be confirmed.**
- **Structural CROSS CHECK needed.**

TT

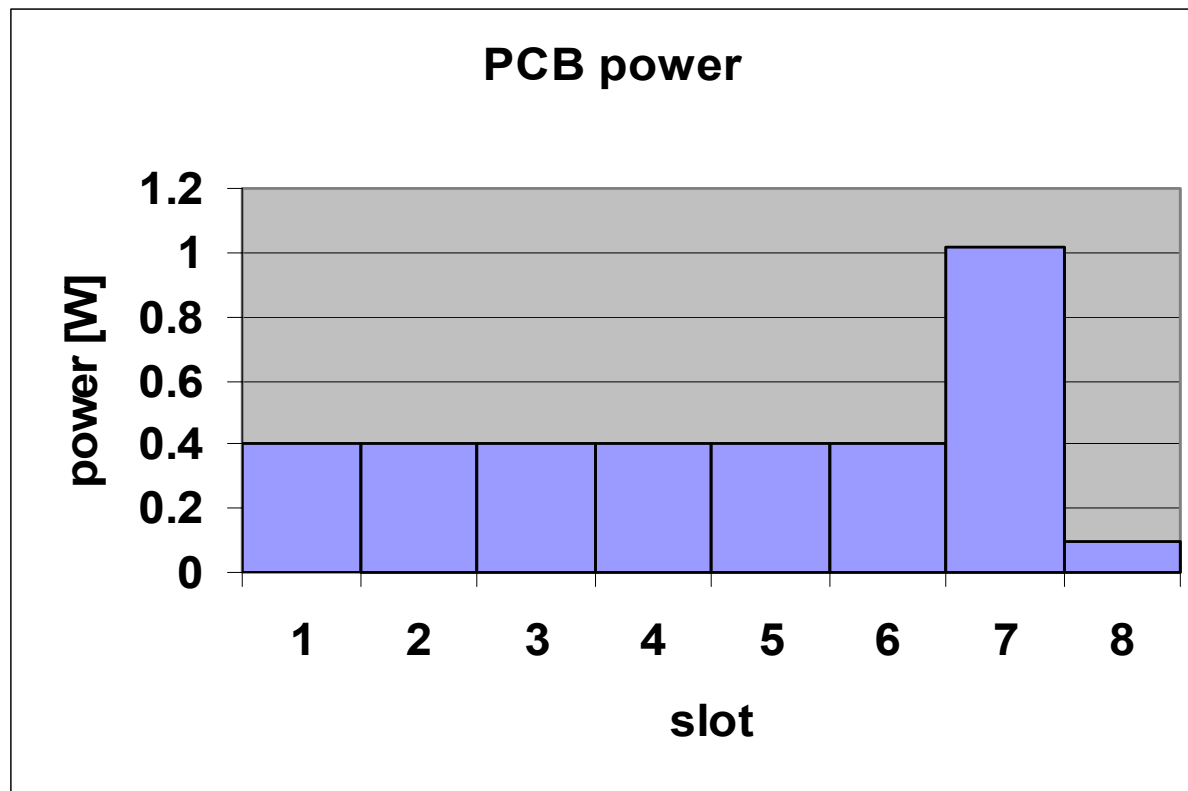

TT

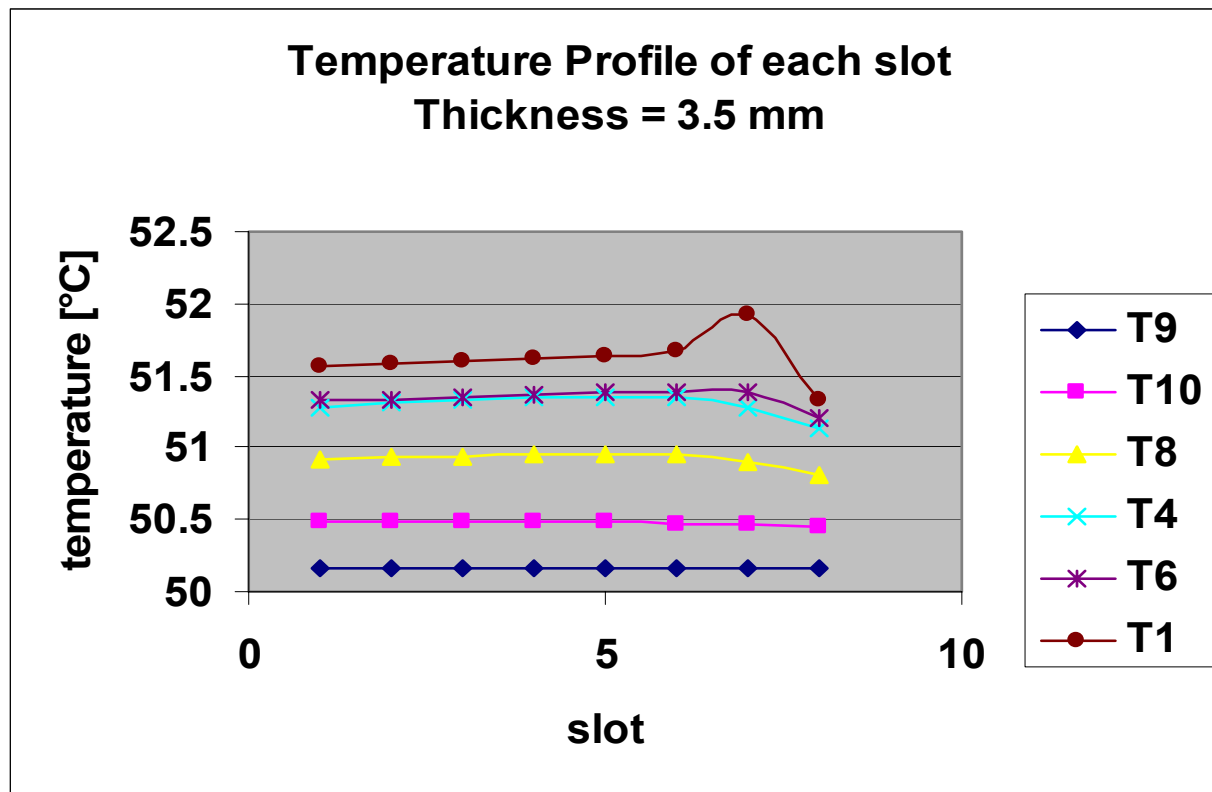

TT

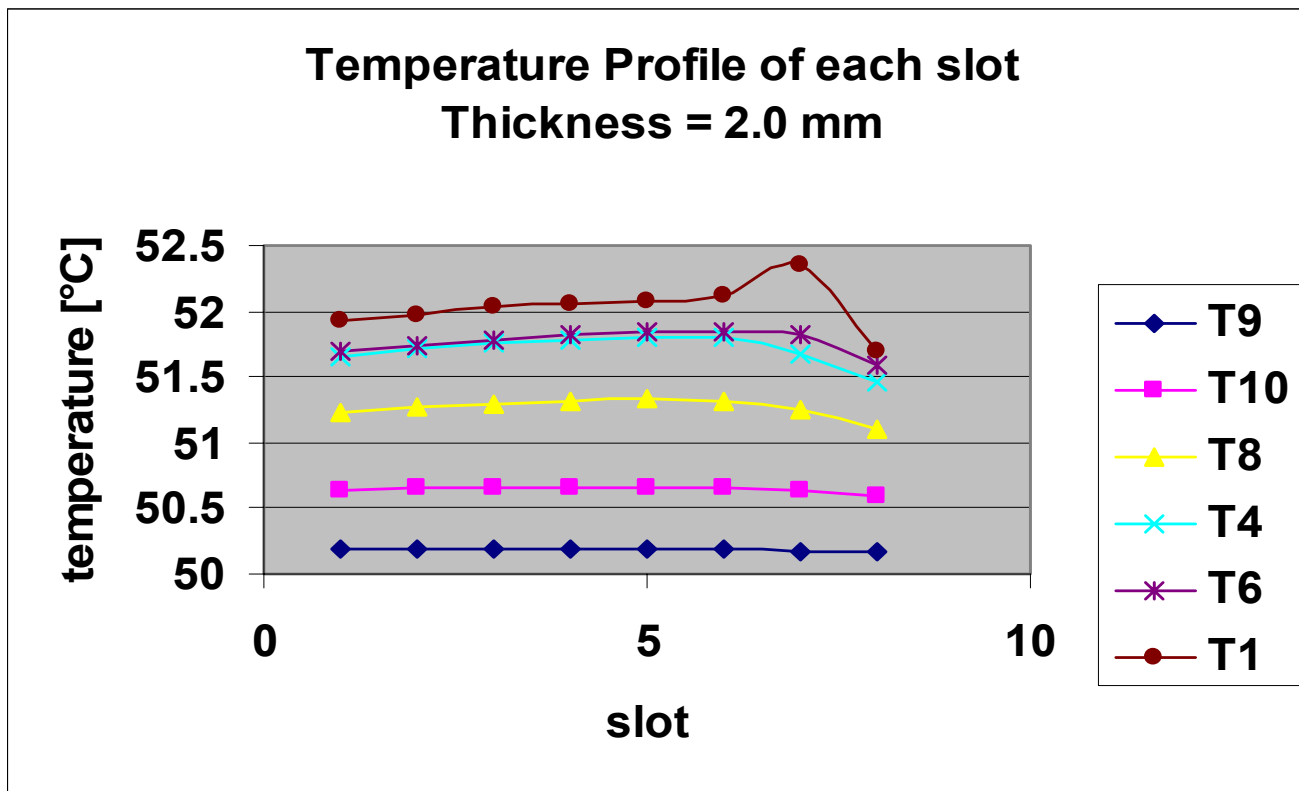

TT - CRATE

mass saving per wall (total is double)

TT	8 slots		quantity:	1
	SP2=	2 mm	saving:	1.5 g per slot
	SP3=	7 mm		
	SC=	2 mm	saving:	9.8 g per slot
	SP6=	2 mm	saving:	1.3 g per slot
	SP10=	2 mm	saving:	0.7 g per slot
	SC2=	7 mm	saving:	3.5 g per slot
			total:	16.8 g per slot
@55°C	-135 g each			-135 g TOTAL

U

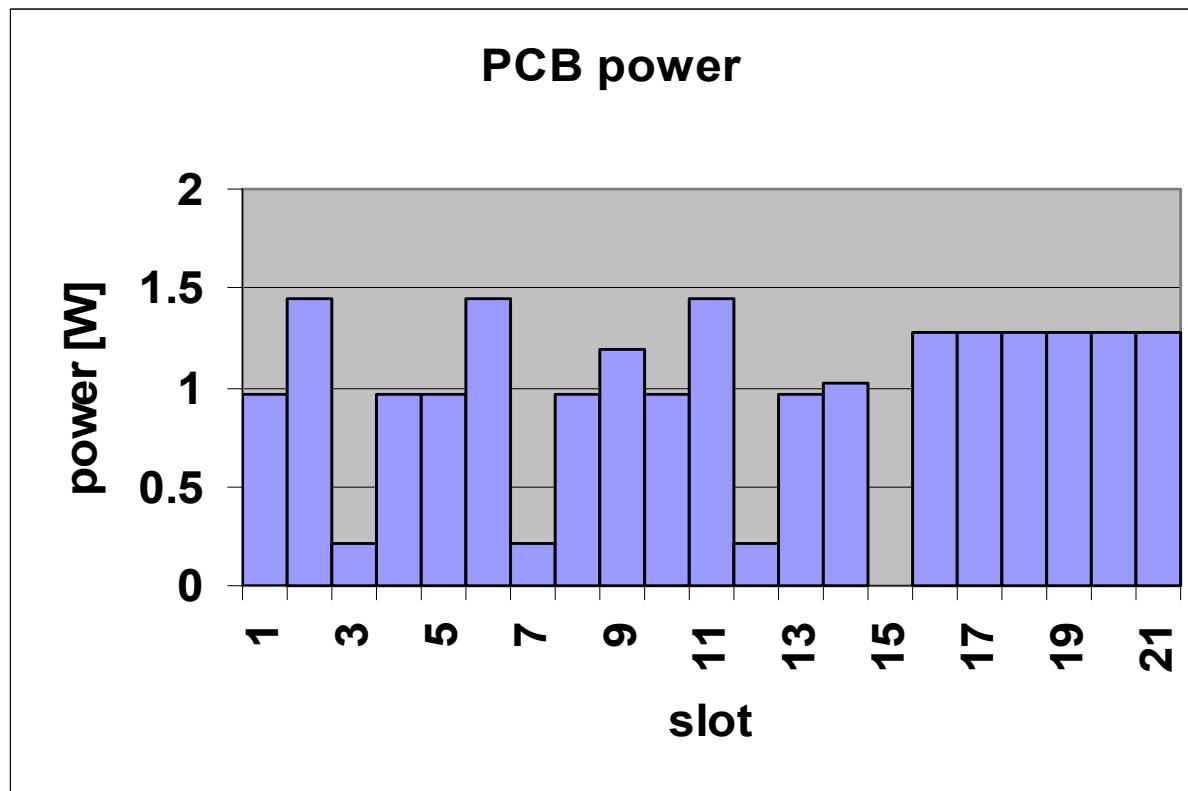

U

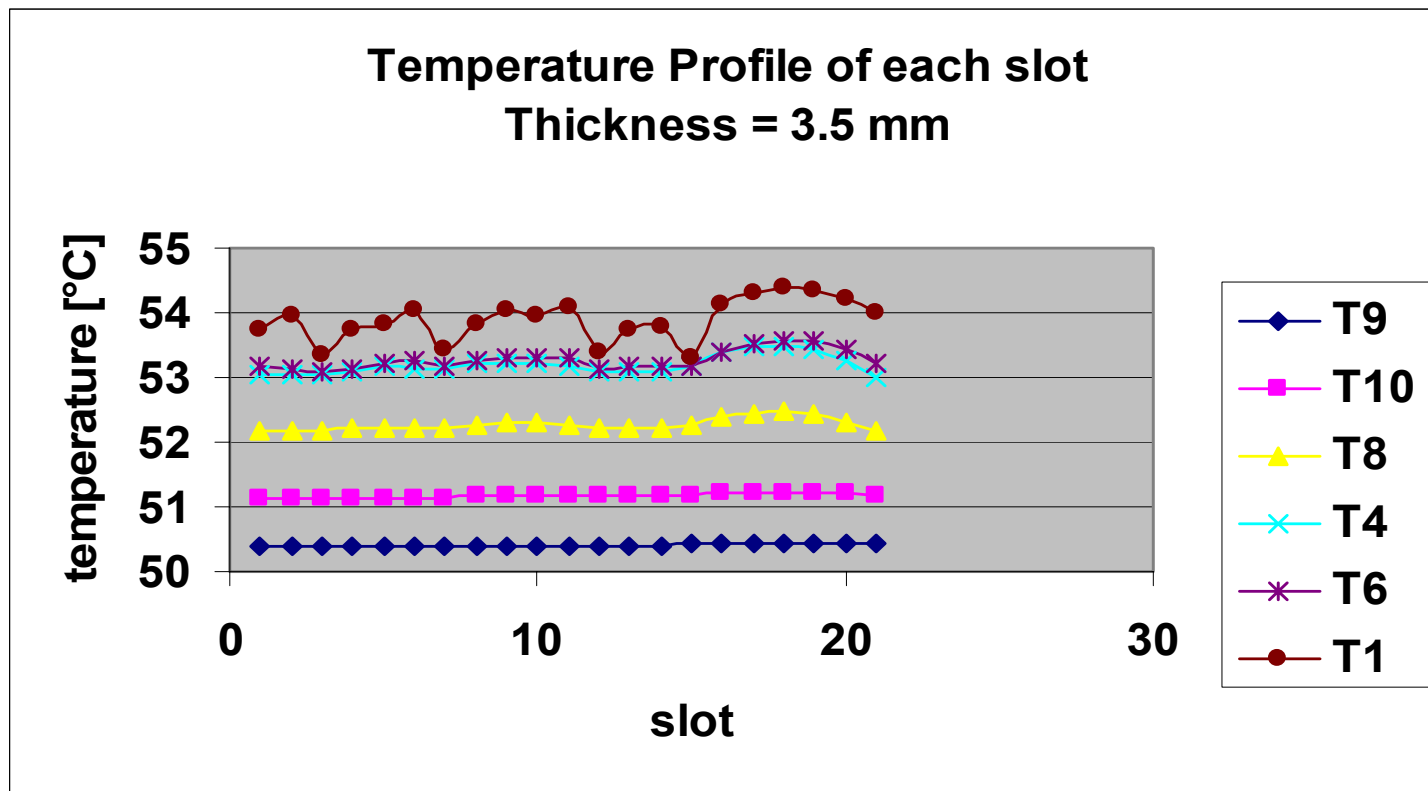

U

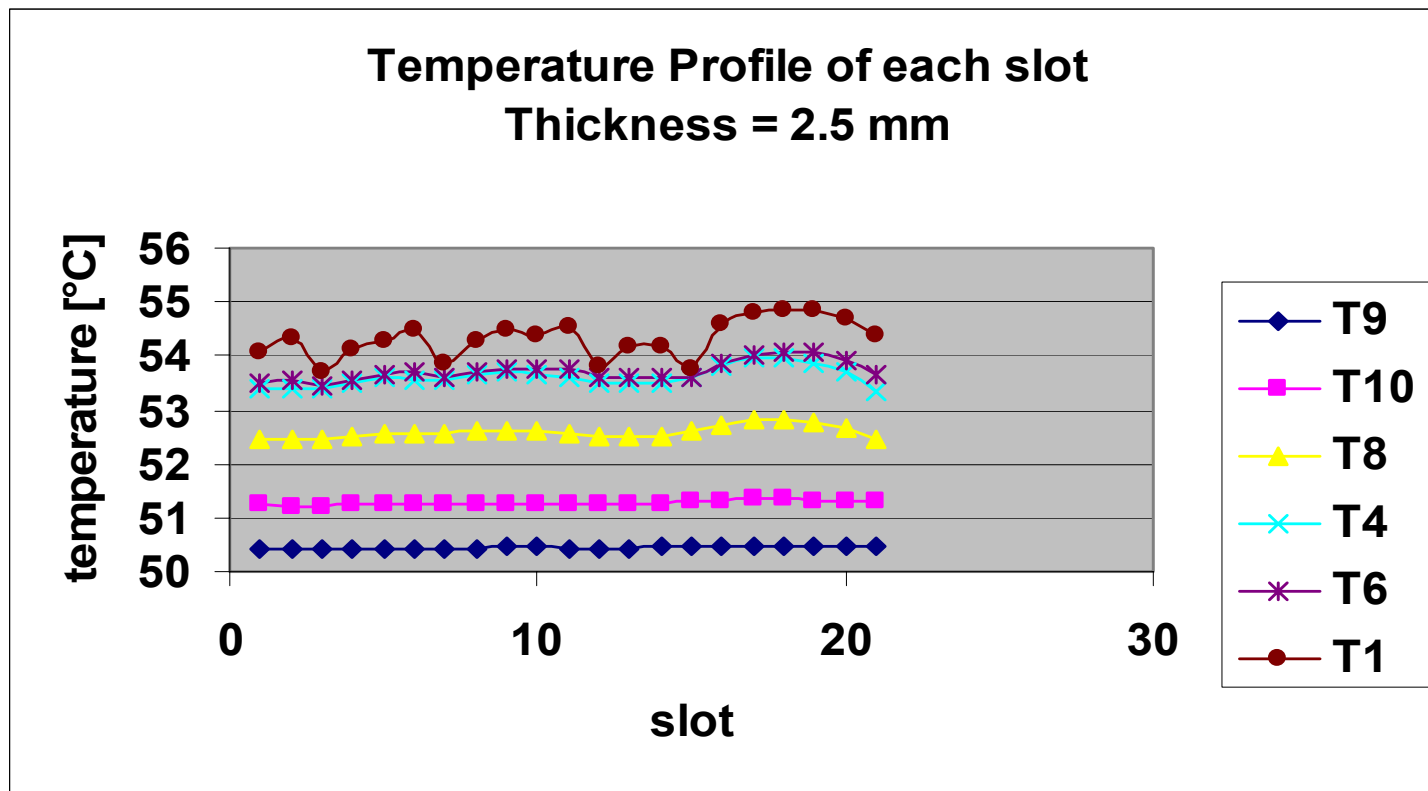

U - CRATE

mass saving per wall (total is double)

U	21 slots		quantity:	2
	SP2=	2.5 mm	saving:	1.0 g per slot
	SP3=	6.0 mm		
	SC=	2.5 mm	saving:	6.5 g per slot
	SP6=	3.0 mm	saving:	0.4 g per slot
	SP10=	3.0 mm	saving:	0.2 g per slot
	SC2=	8.0 mm	saving:	2.4 g per slot
		total:	10.5 g per slot	
@55°C	-222 g each		-443 g TOTAL	

T

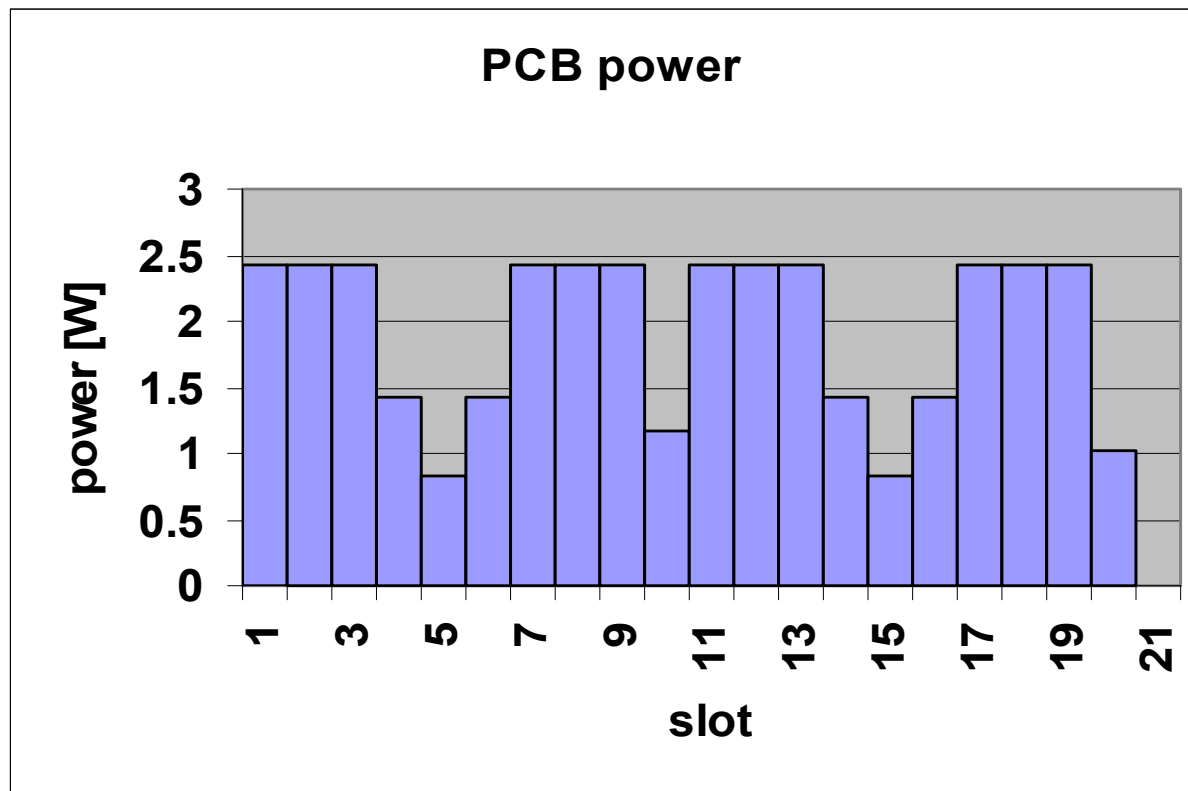

T

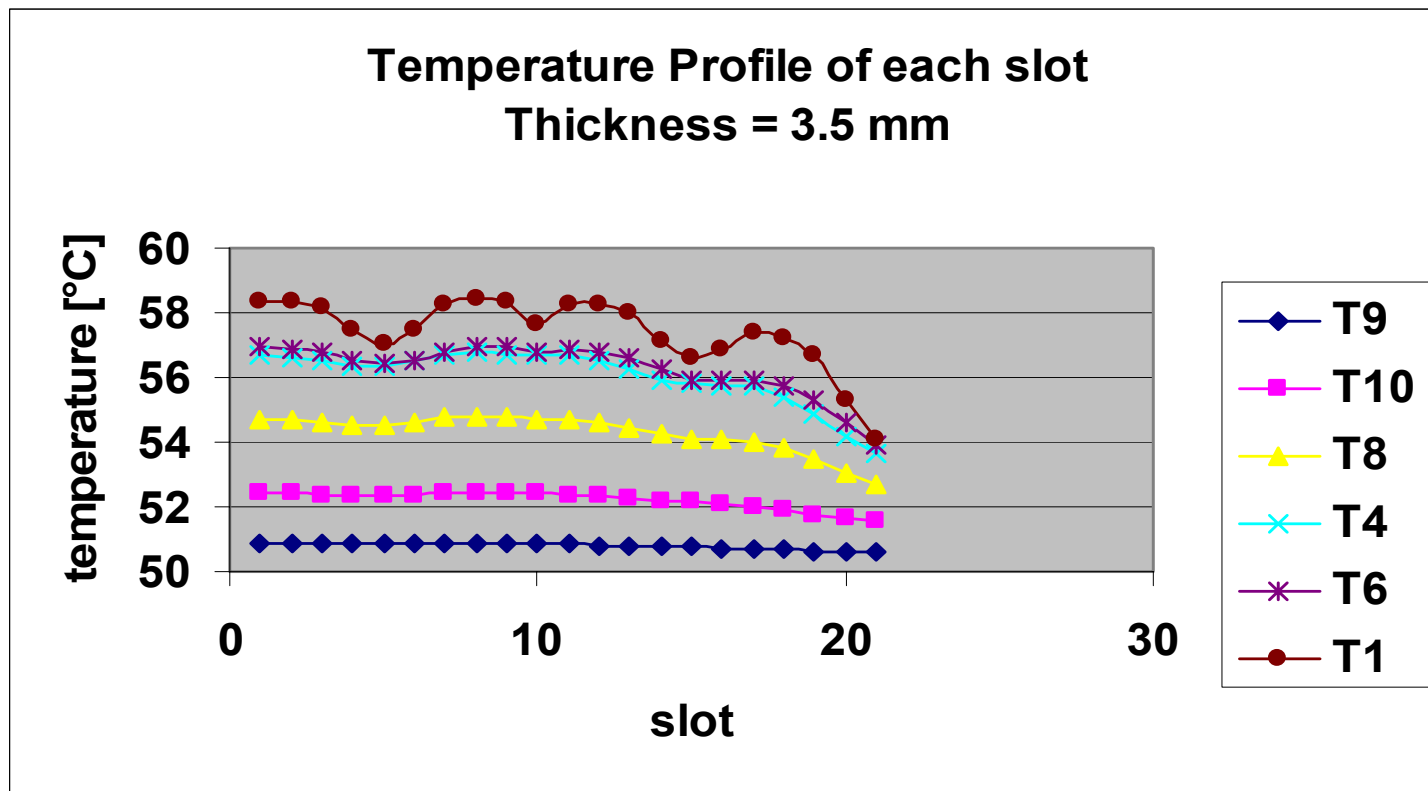

T

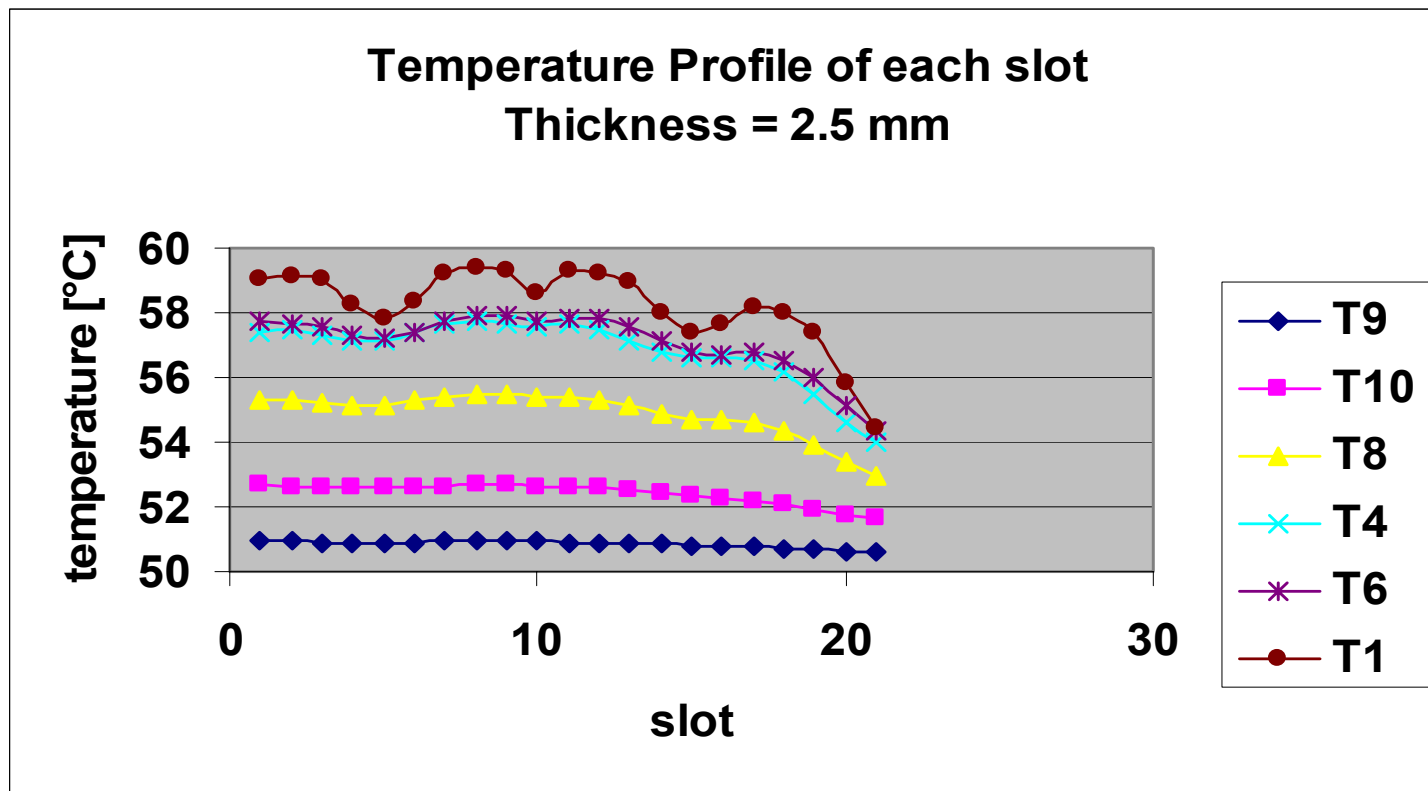

T - CRATE

mass saving per wall (total is double)

T	21 slots		quantity:	8
	SP2=	2.5 mm	saving:	1.0 g per slot
	SP3=	6.0 mm		
	SC=	2.5 mm	saving:	6.5 g per slot
	SP6=	3.0 mm	saving:	0.4 g per slot
	SP10=	3.0 mm	saving:	0.2 g per slot
	SC2=	8.0 mm	saving:	2.4 g per slot
			total:	10.5 g per slot
@60°C	-222 g each		-1772 g TOTAL	

!WARNING! STRUCTURALLY CRITICAL

JPD

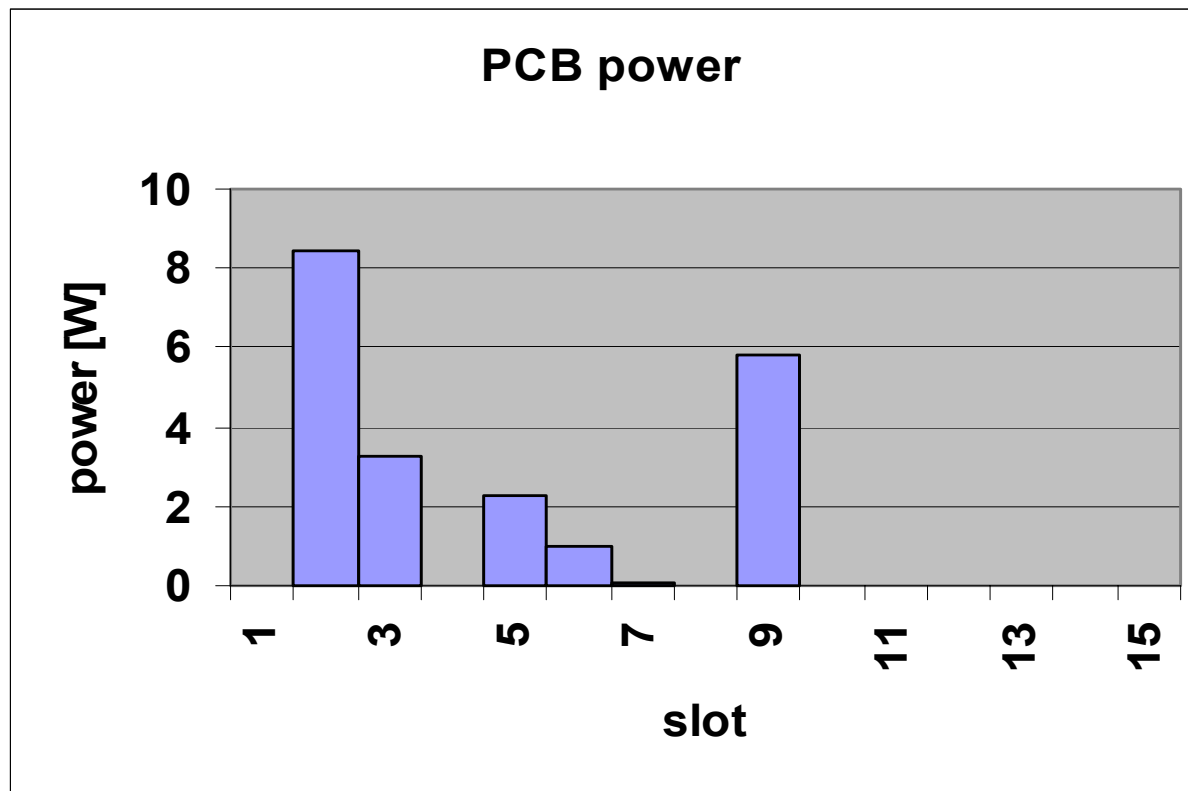

JPD

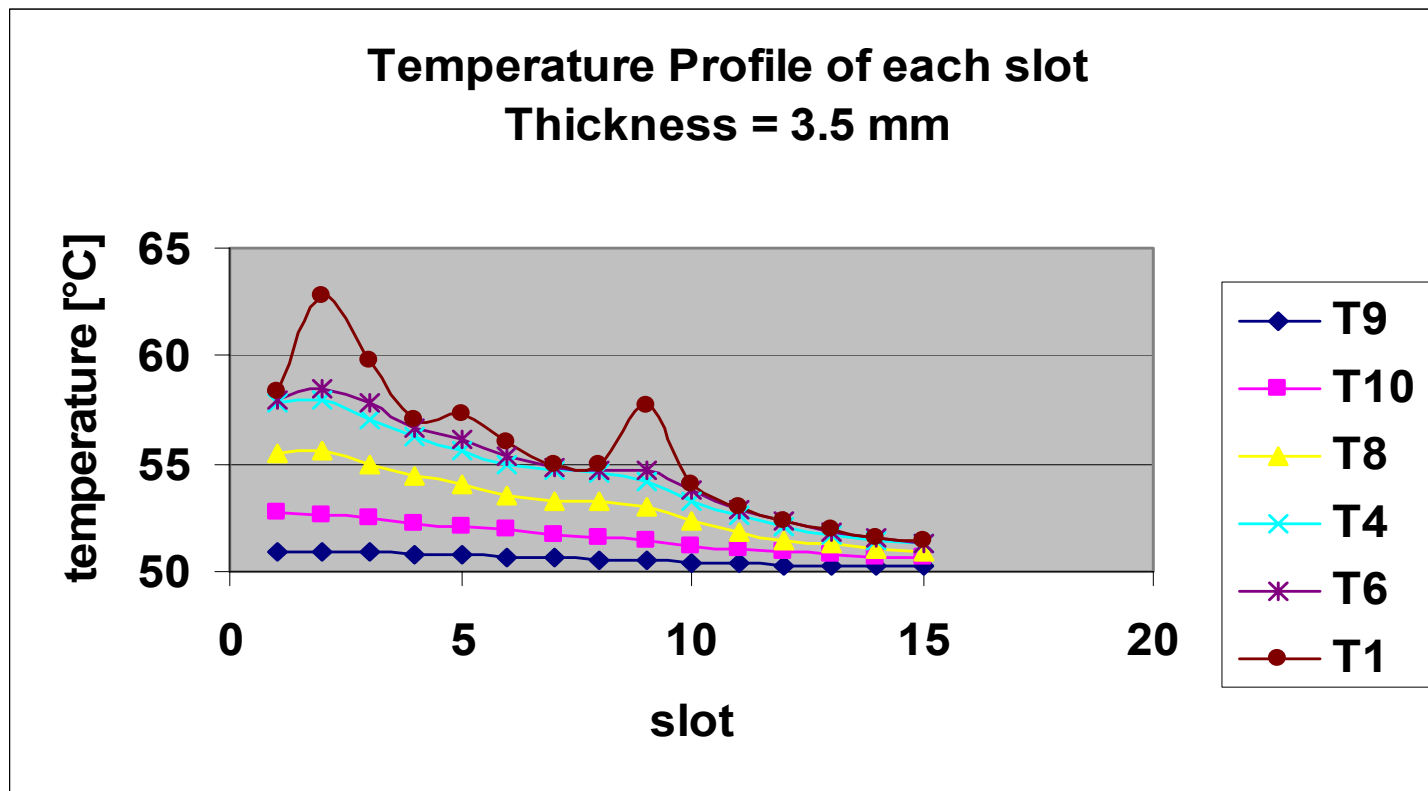

JPD - CRATE

mass saving per wall (total is double)

JPD	15 slots	quantity:	1
SP2=	3.5 mm	saving:	0.0 g per slot
SP3=	4 mm		
SC=	3.5 mm	saving:	0.0 g per slot
SP6=	3.5 mm	saving:	0.0 g per slot
SP10=	3.5 mm	saving:	0.0 g per slot
SC2=	10 mm	saving:	0.0 g per slot
		total:	0.0 g per slot
@62°C	0 g each	0 g TOTAL	

JT

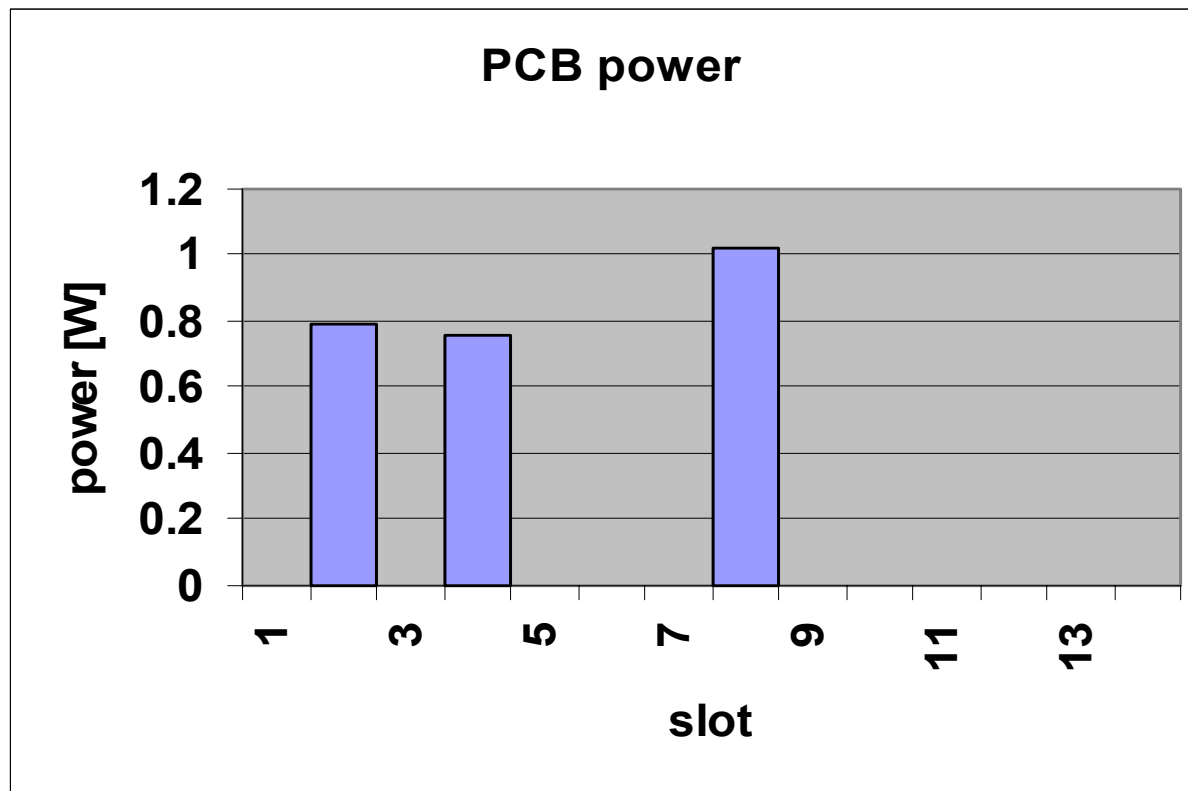

JT

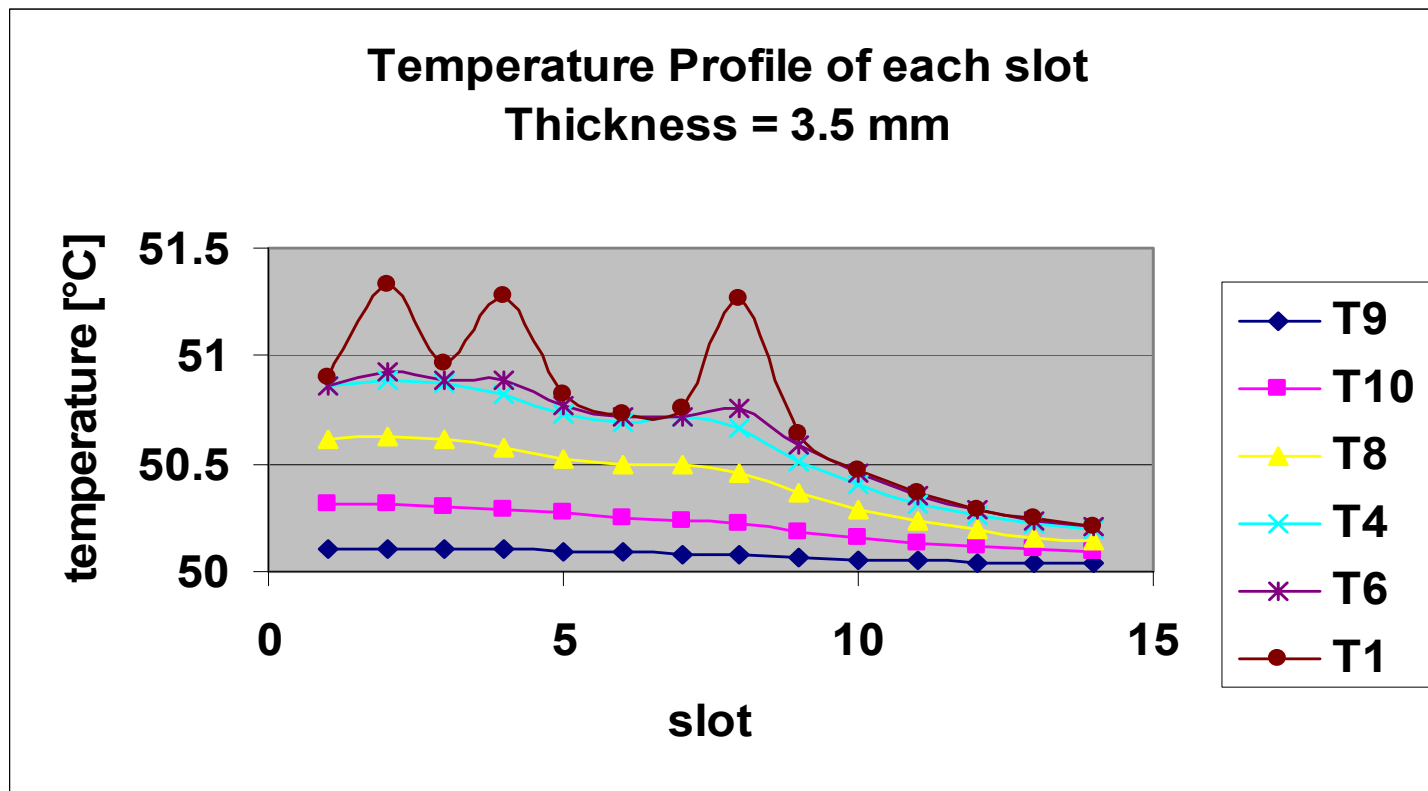

JT

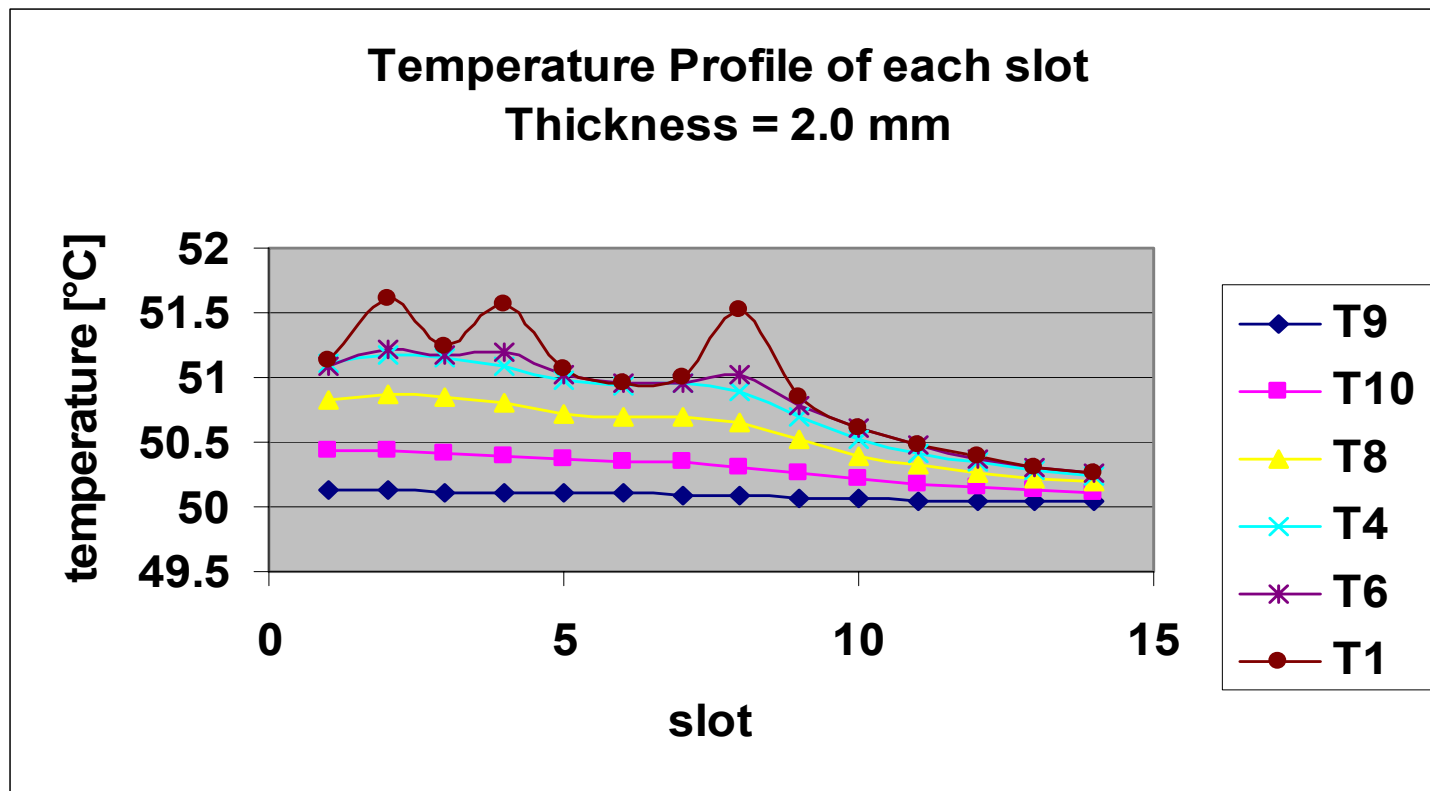

JT - CRATE

mass saving per wall (total is double)

JT	14 slots		quantity:	1
	SP2=	2 mm	saving:	1.5 g per slot
	SP3=	7 mm		
	SC=	2 mm	saving:	9.8 g per slot
	SP6=	2 mm	saving:	1.3 g per slot
	SP10=	2 mm	saving:	0.7 g per slot
	SC2=	7 mm	saving:	3.5 g per slot
			total:	16.8 g per slot
@55°C	-236 g each			-236 g TOTAL

M

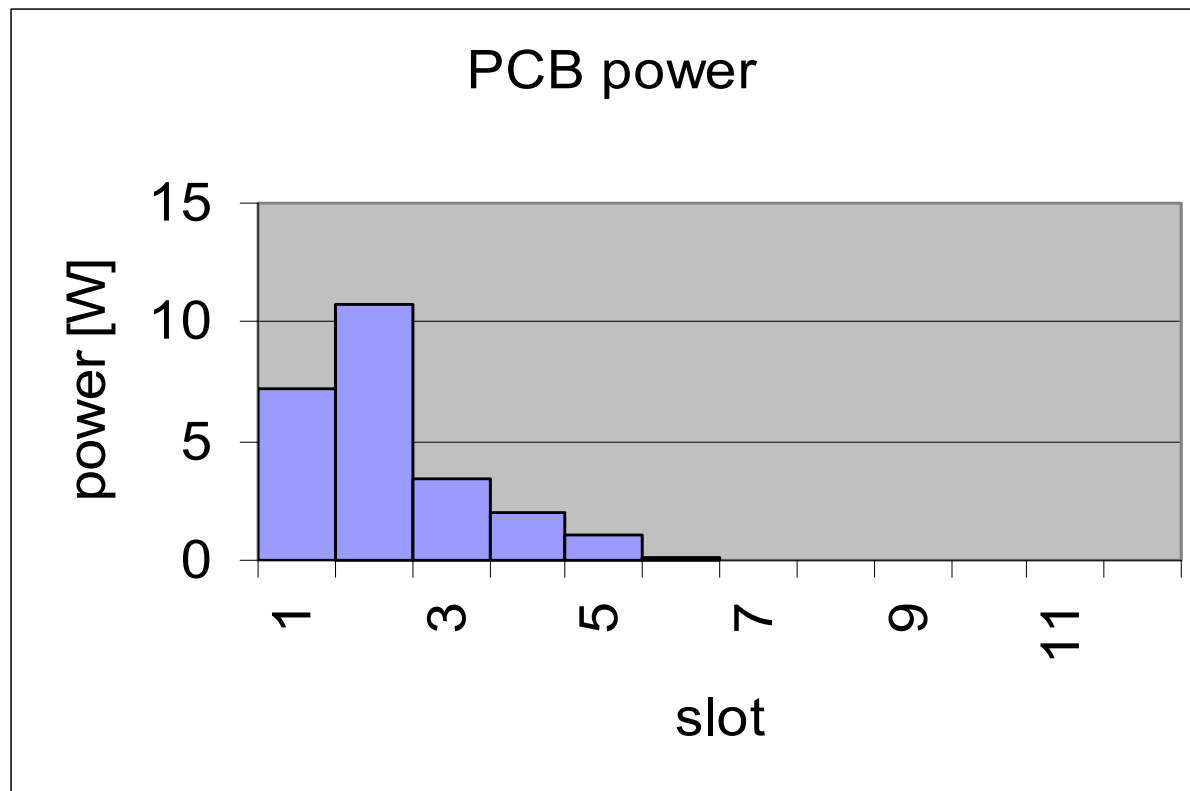

M

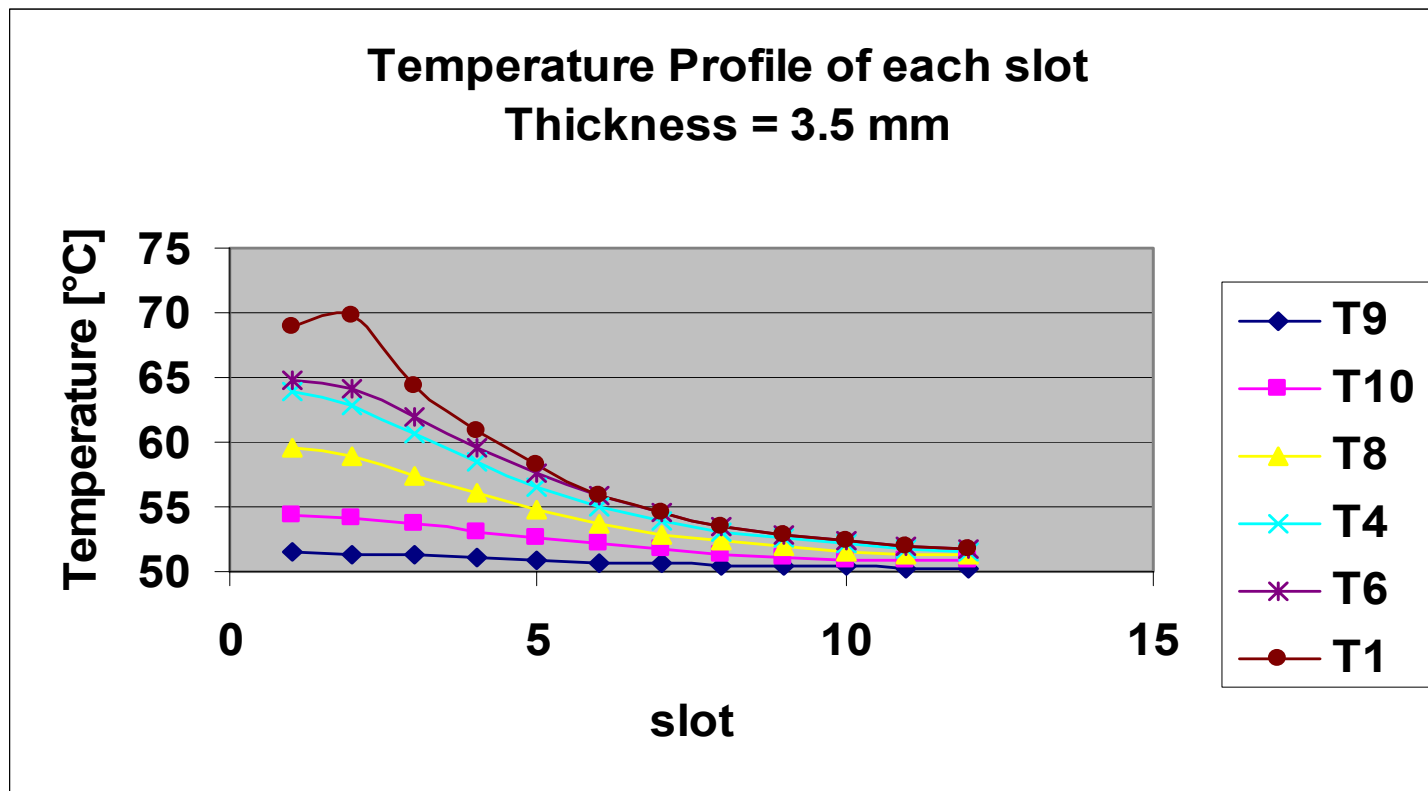

M

Alternative power distribution

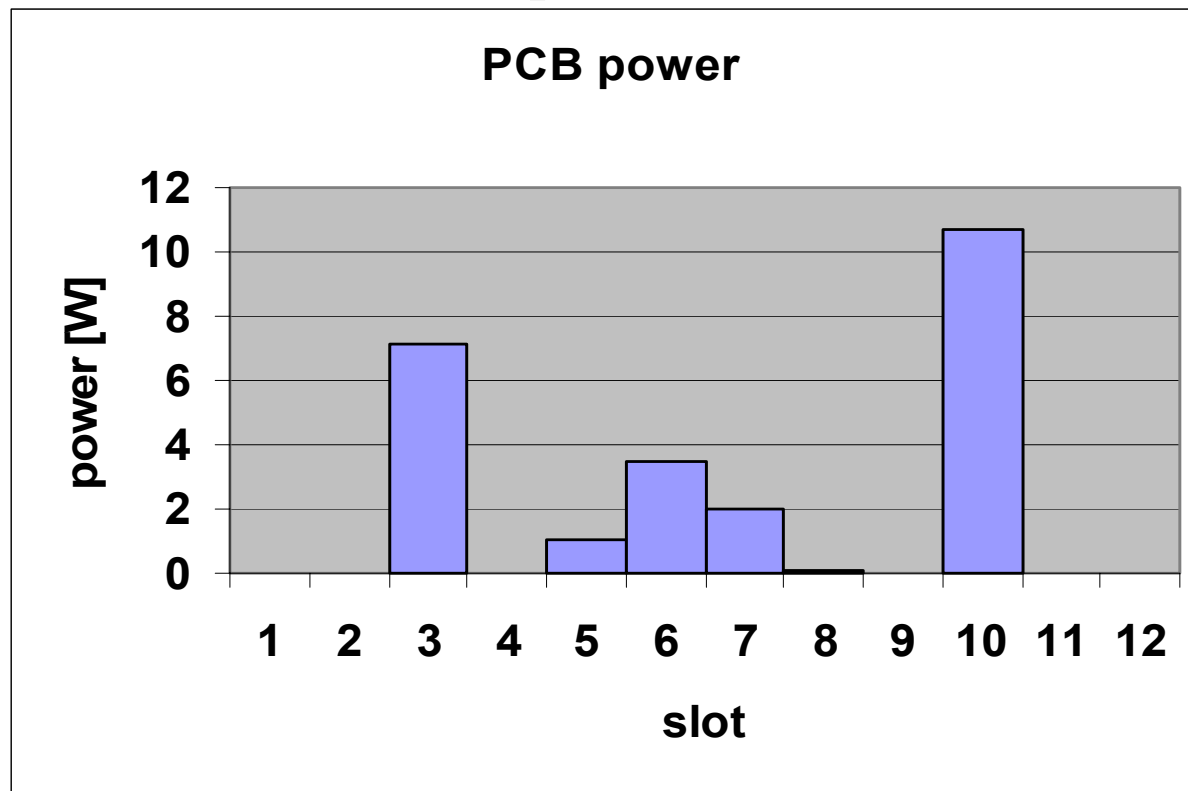

M

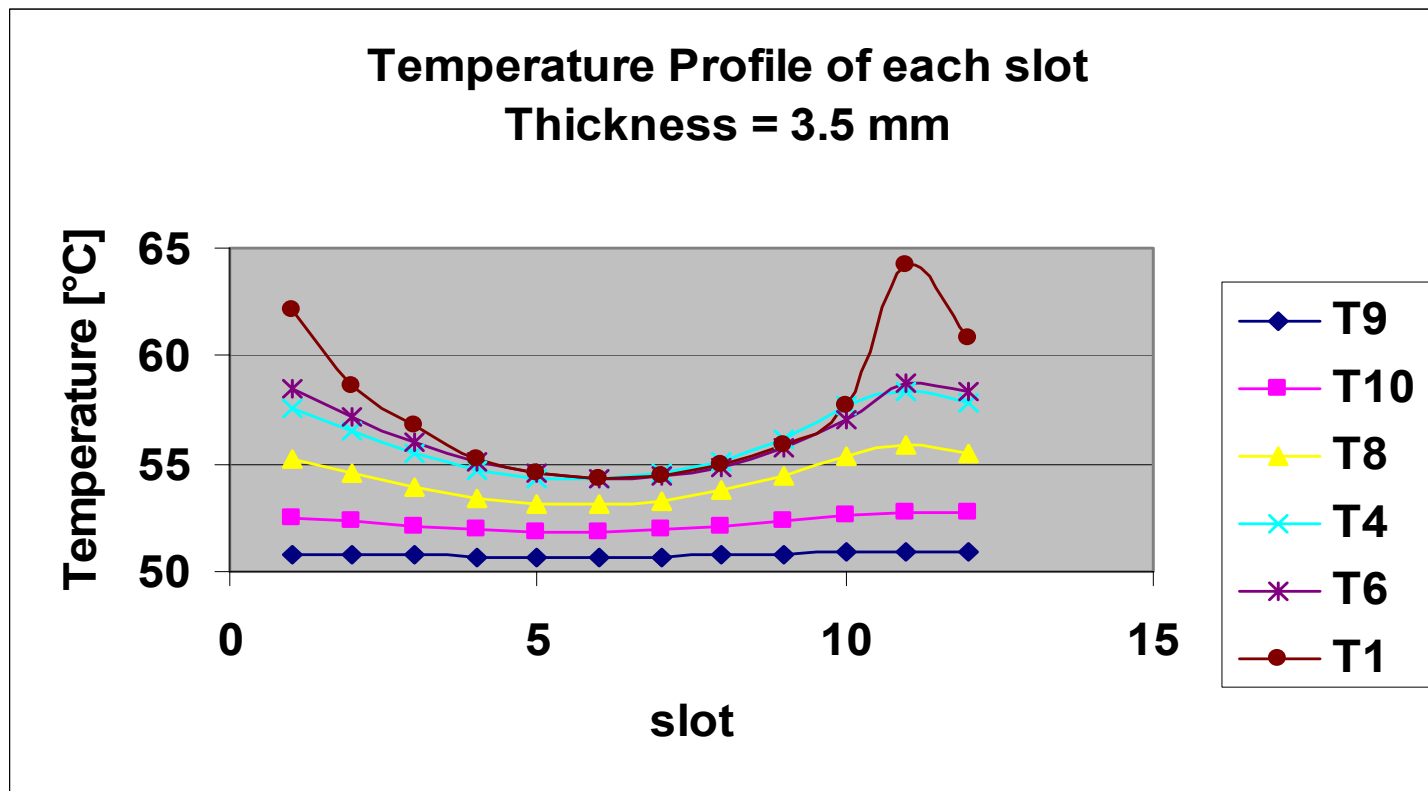

M - CRATE

mass saving per wall (total is double)

M	12 slots		quantity:	1
	SP2=	3.5 mm	saving:	0.0 g per slot
	SP3=	4 mm		
	SC=	3.5 mm	saving:	0.0 g per slot
	SP6=	3.5 mm	saving:	0.0 g per slot
	SP10=	3.5 mm	saving:	0.0 g per slot
	SC2=	10 mm	saving:	0.0 g per slot
			total:	0.0 g per slot
@63÷70°C	0 g each		0 g TOTAL	

UG

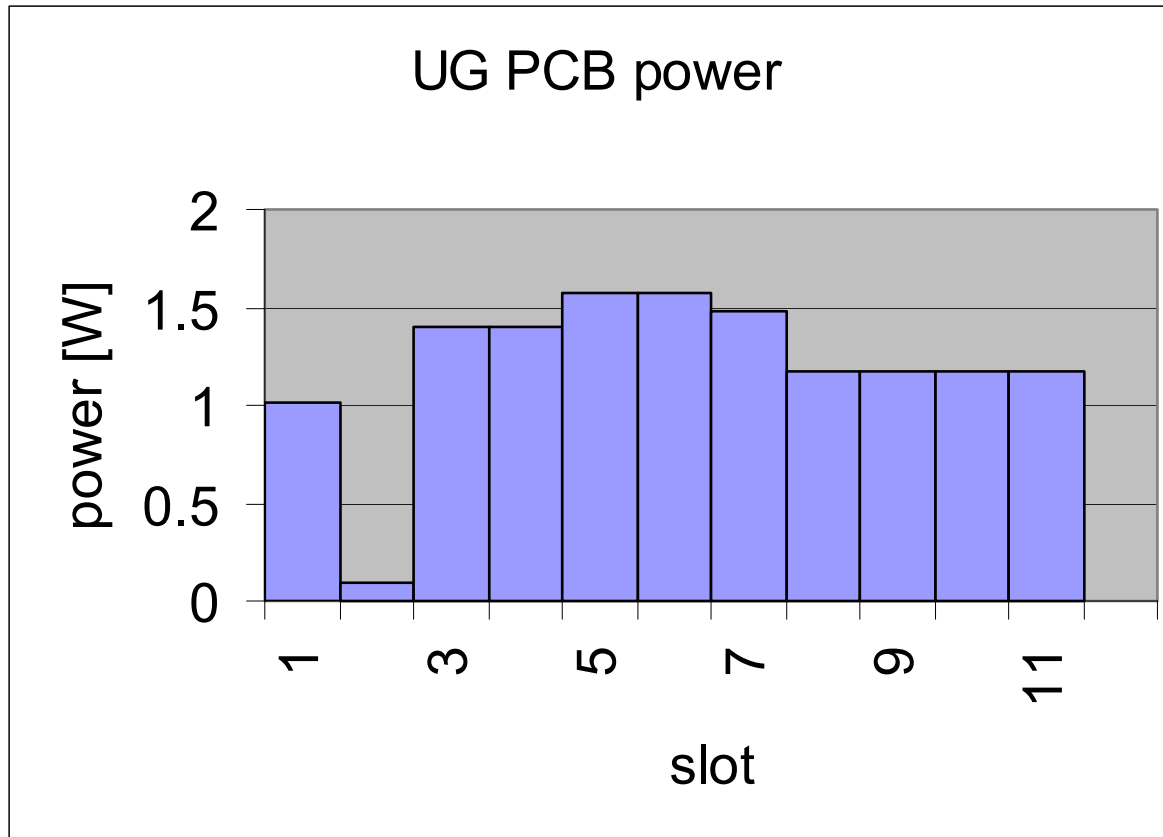

UG

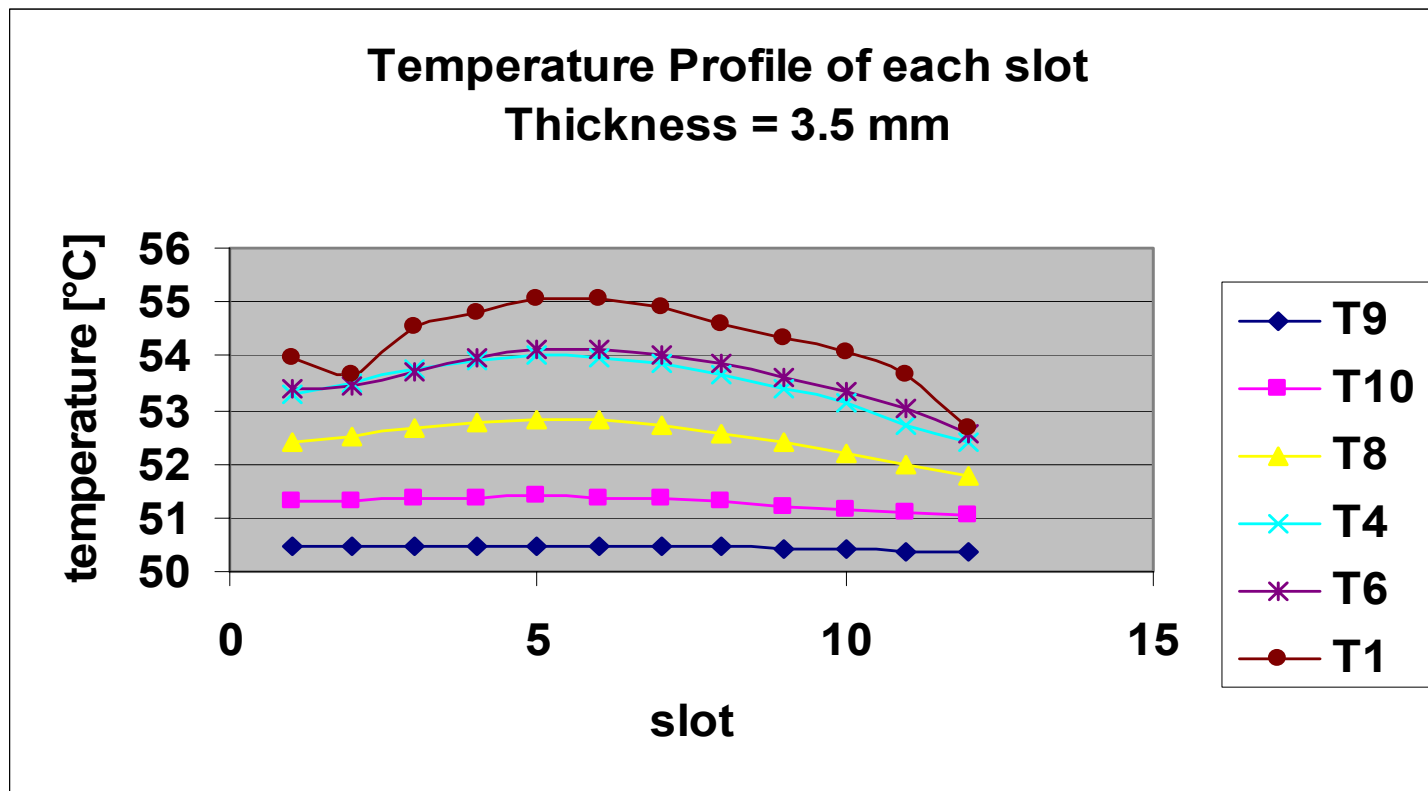

UG

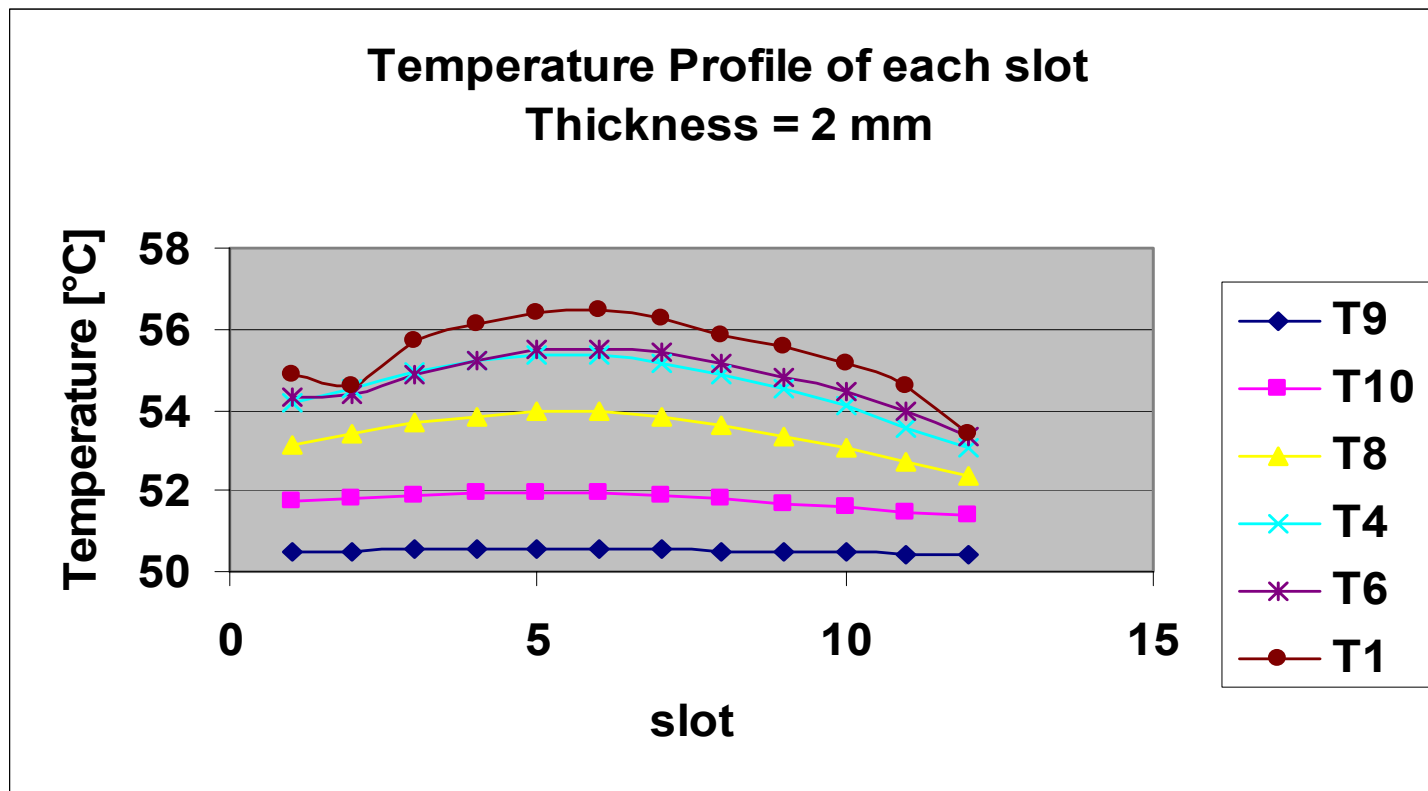

UG - CRATE

mass saving per wall (total is double)

UG	12 slots		quantity:	1
	SP2=	2.0 mm	saving:	1.5 g per slot
	SP3=	7.0 mm		
	SC=	2.0 mm	saving:	9.8 g per slot
	SP6=	2.0 mm	saving:	1.3 g per slot
	SP10=	2.0 mm	saving:	0.7 g per slot
	SC2=	7.0 mm	saving:	3.5 g per slot
			total:	16.8 g per slot
@56.5°C	-202 g each			-202 g TOTAL

S

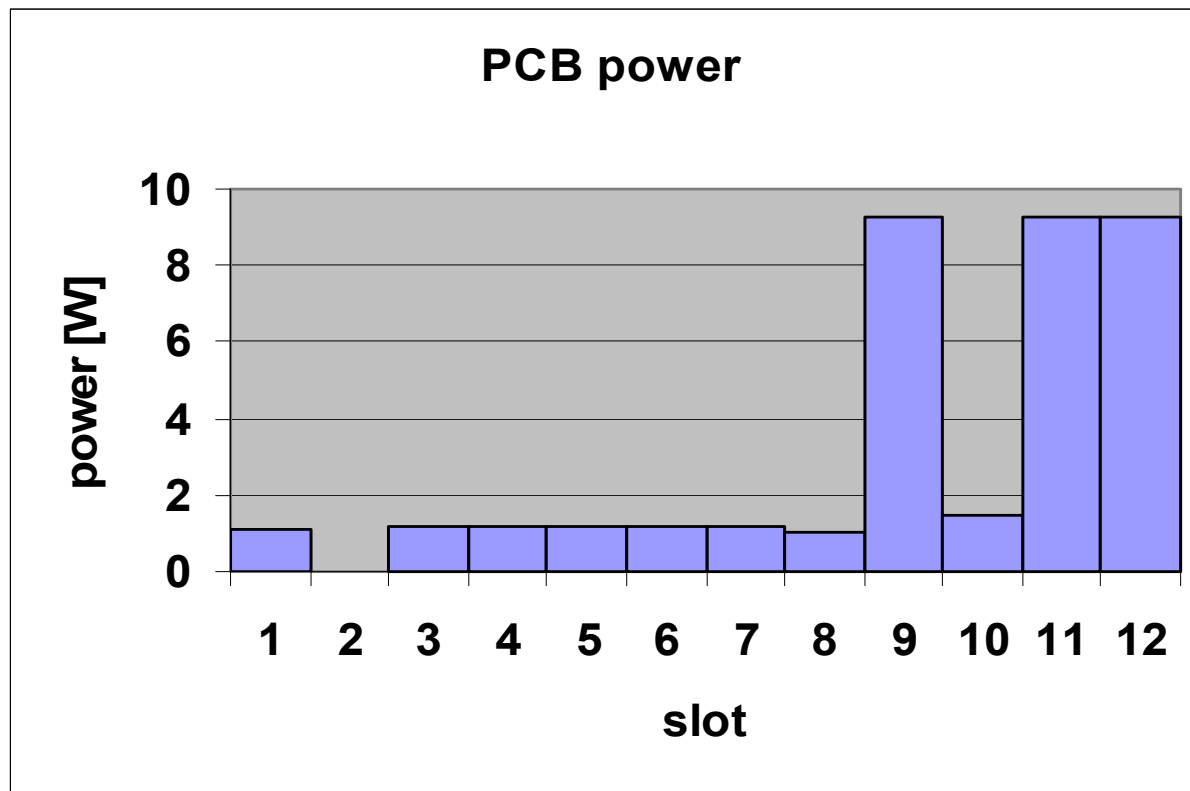

S

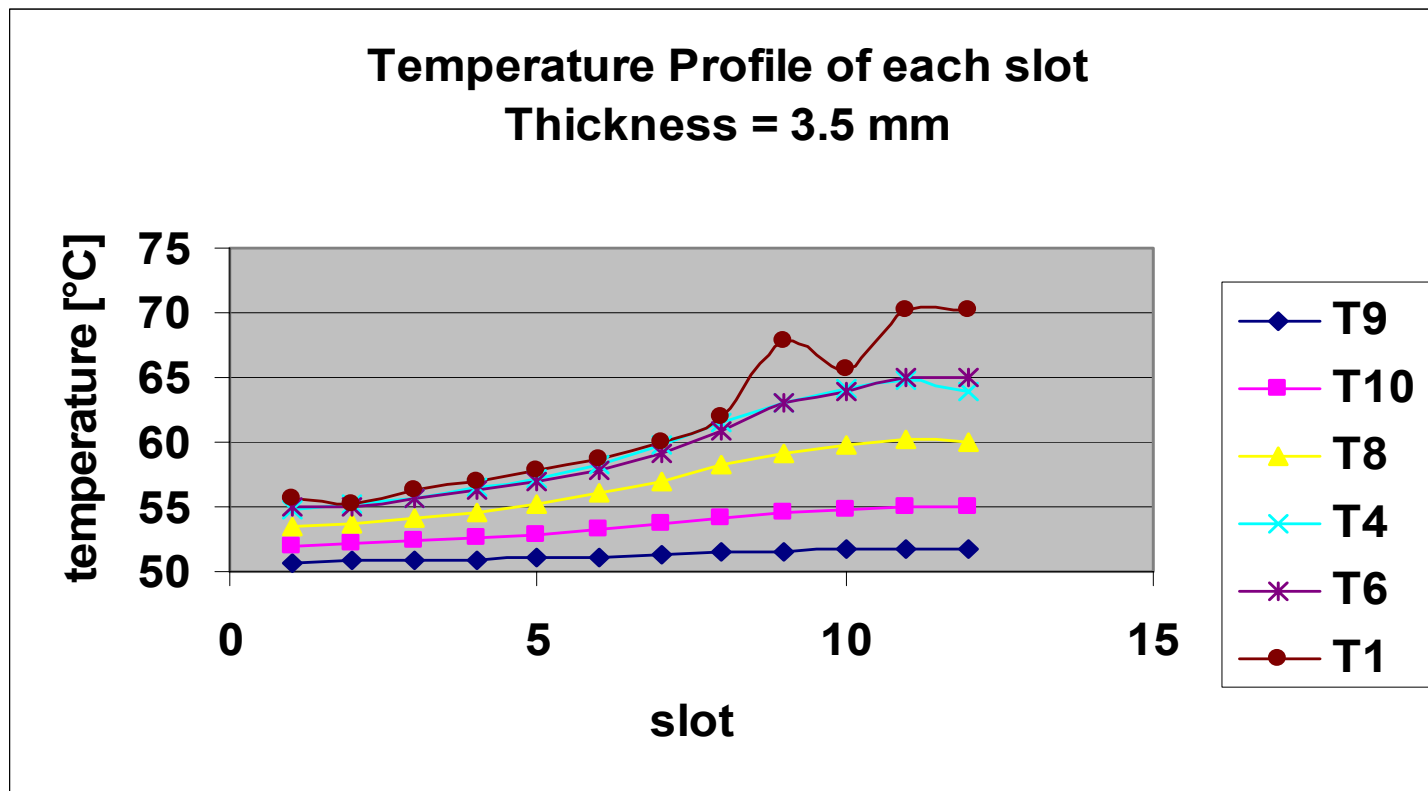

S

Alternative power distribution

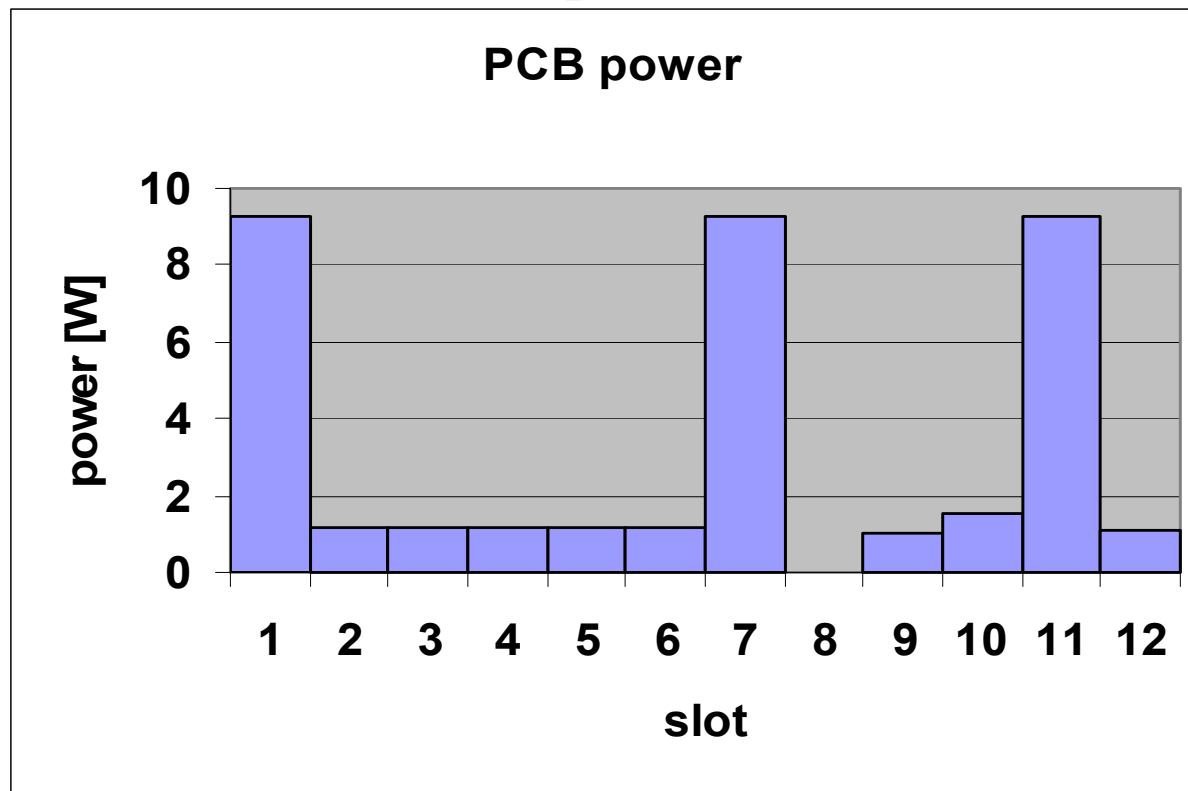

S

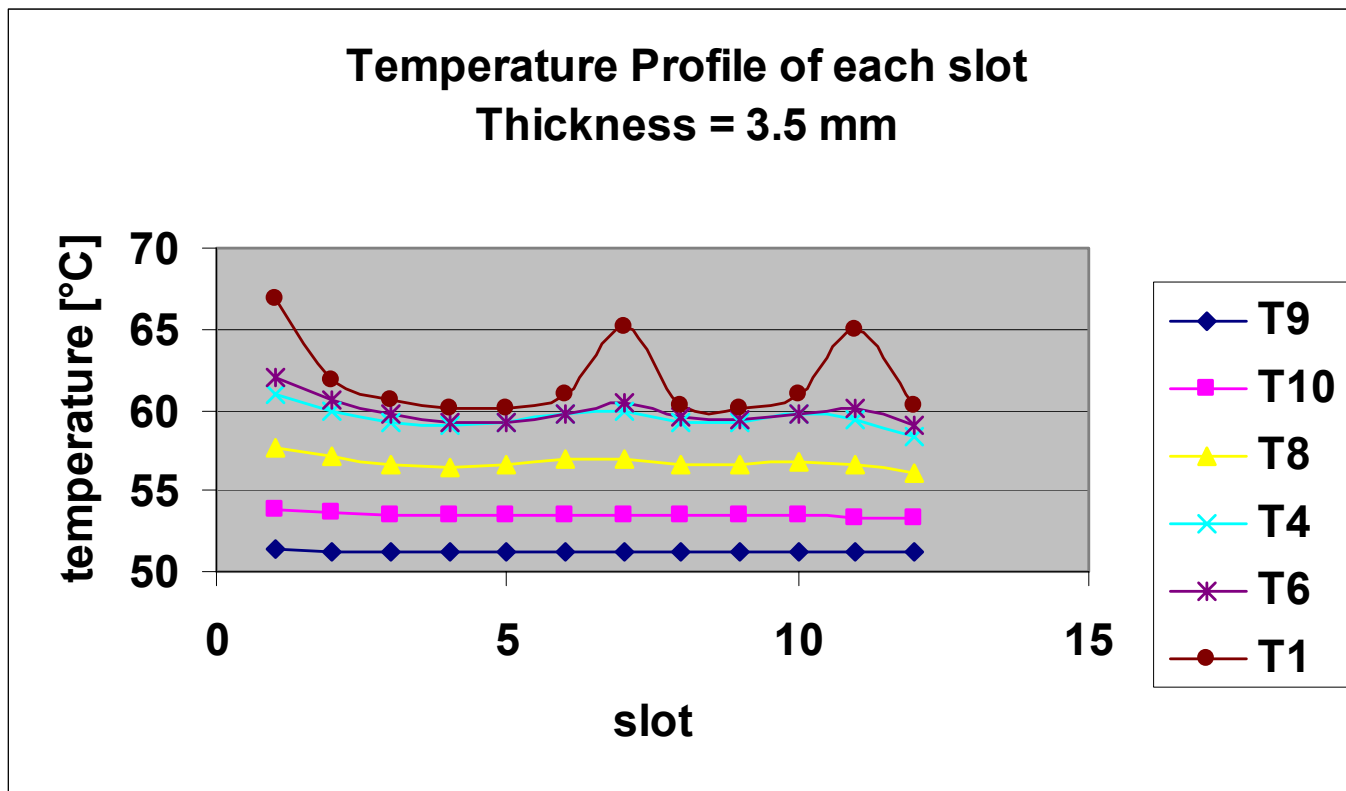

S - CRATE

mass saving per wall (total is double)

S	12 slots		quantity:	4
	SP2=	3.5 mm	saving:	0.0 g per slot
	SP3=	4 mm		
	SC=	3.5 mm	saving:	0.0 g per slot
	SP6=	3.5 mm	saving:	0.0 g per slot
	SP10=	3.5 mm	saving:	0.0 g per slot
	SC2=	10 mm	saving:	0.0 g per slot
			total:	0.0 g per slot
@67÷70°C	0 g each		0 g TOTAL	

J

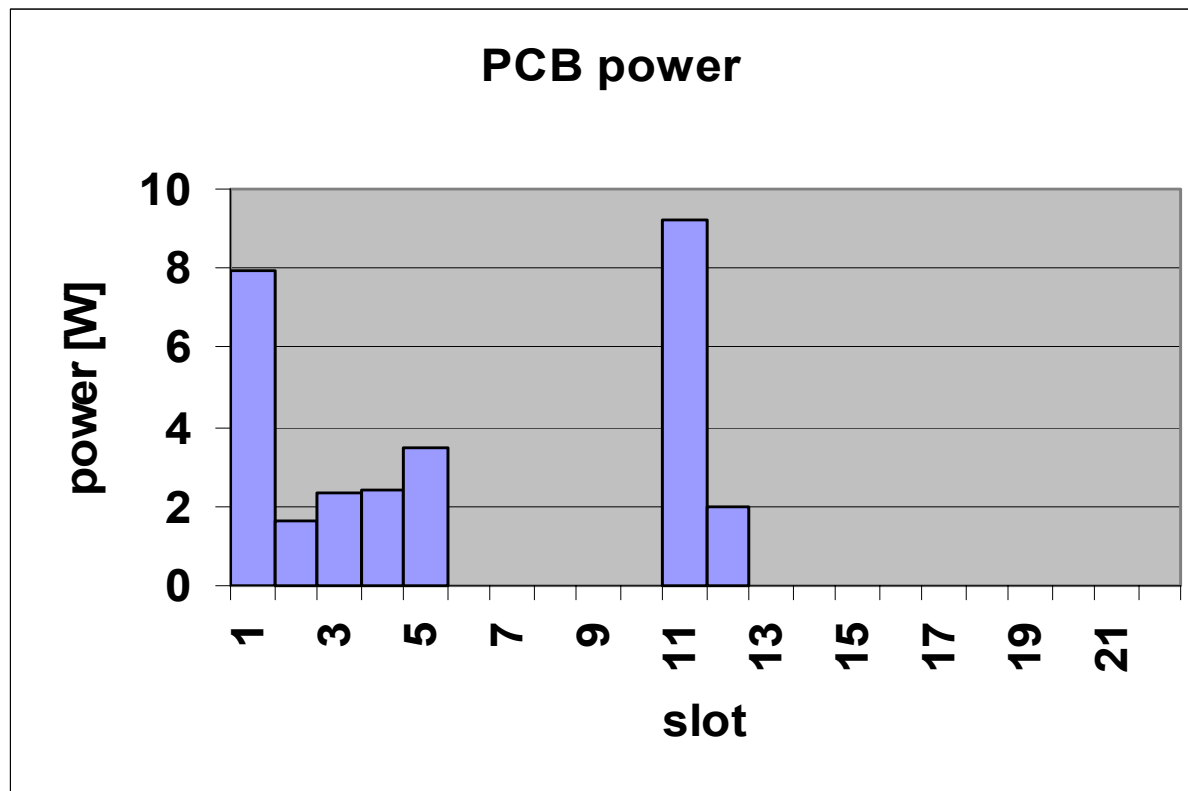

J

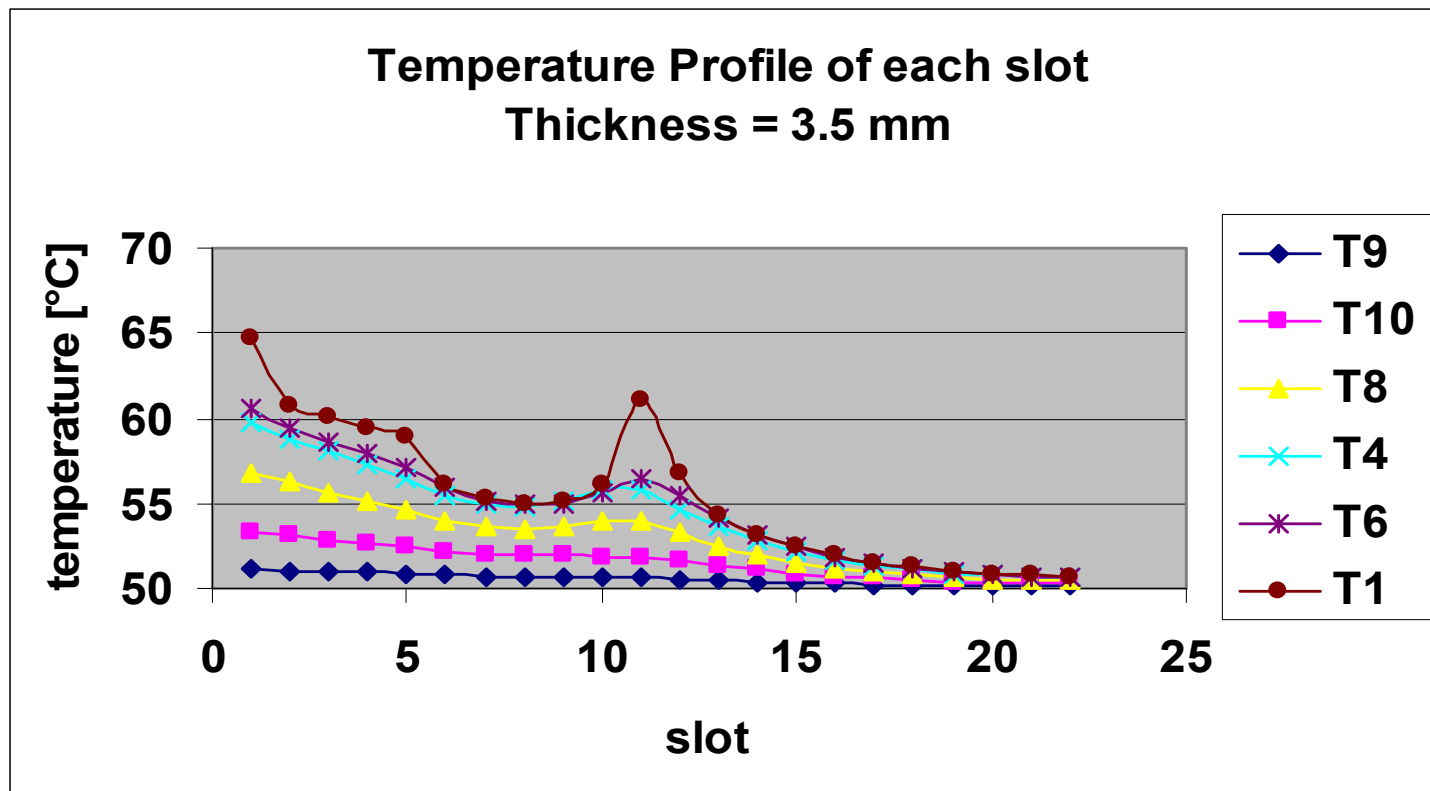

J

Alternative power distribution

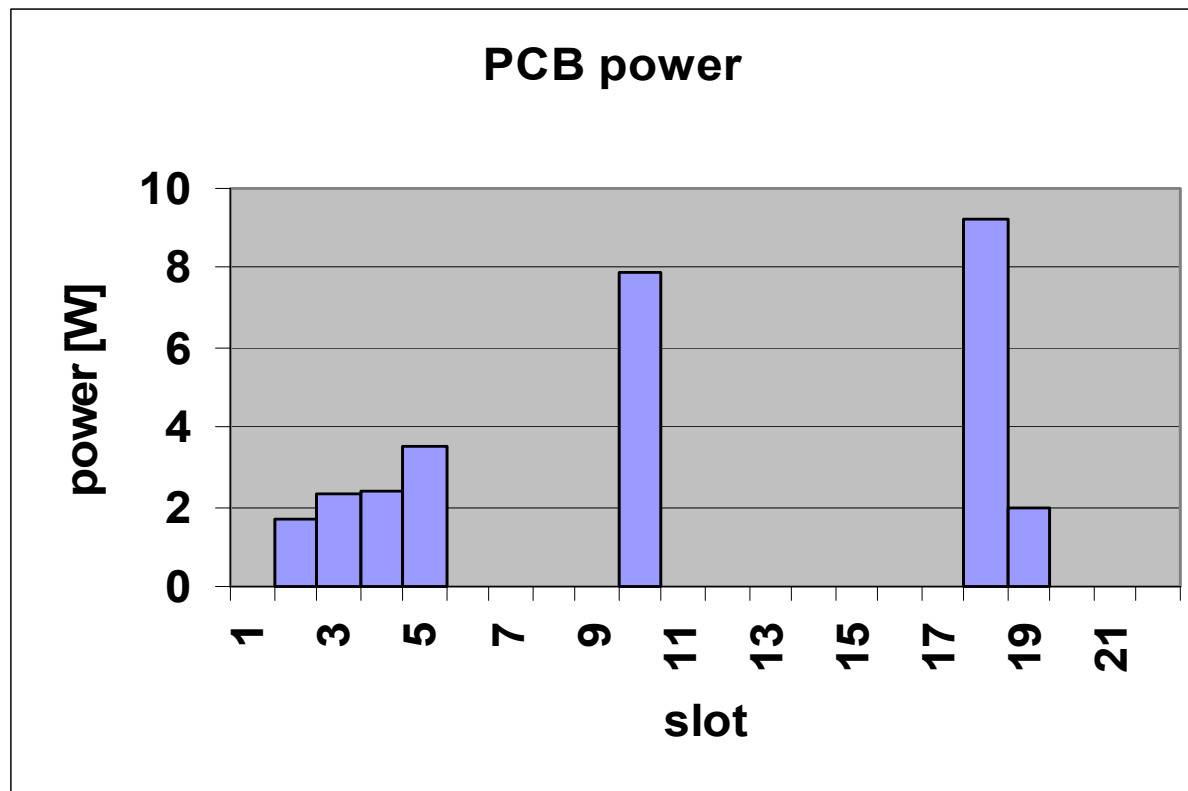

J

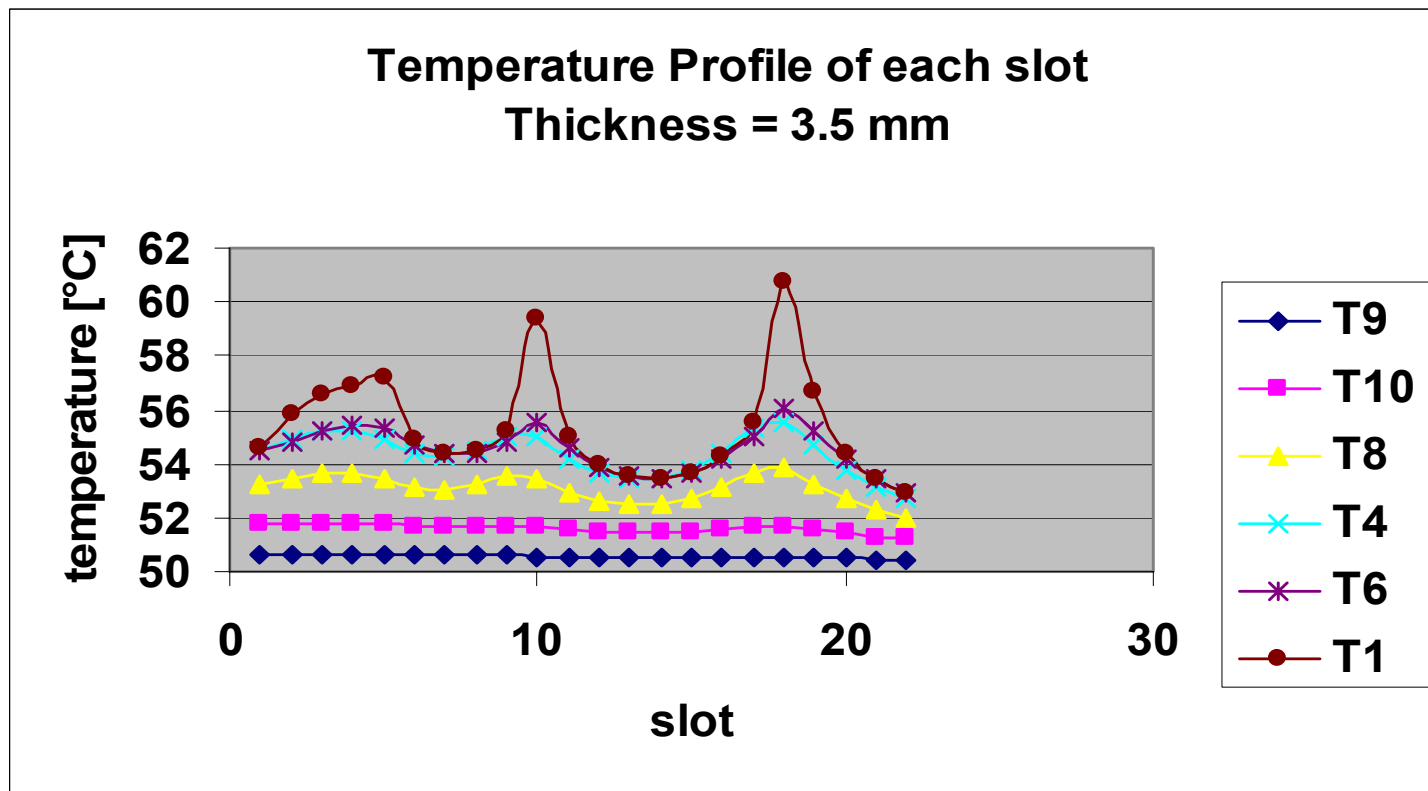

J - CRATE

mass saving per wall (total is double)

J	22 slots		quantity:	1
	SP2=	3.5 mm	saving:	0.0 g per slot
	SP3=	4 mm		
	SC=	3.5 mm	saving:	0.0 g per slot
	SP6=	3.5 mm	saving:	0.0 g per slot
	SP10=	3.5 mm	saving:	0.0 g per slot
	SC2=	10 mm	saving:	0.0 g per slot
			total:	0.0 g per slot
@61÷65°C	0 g each			0 g TOTAL

R

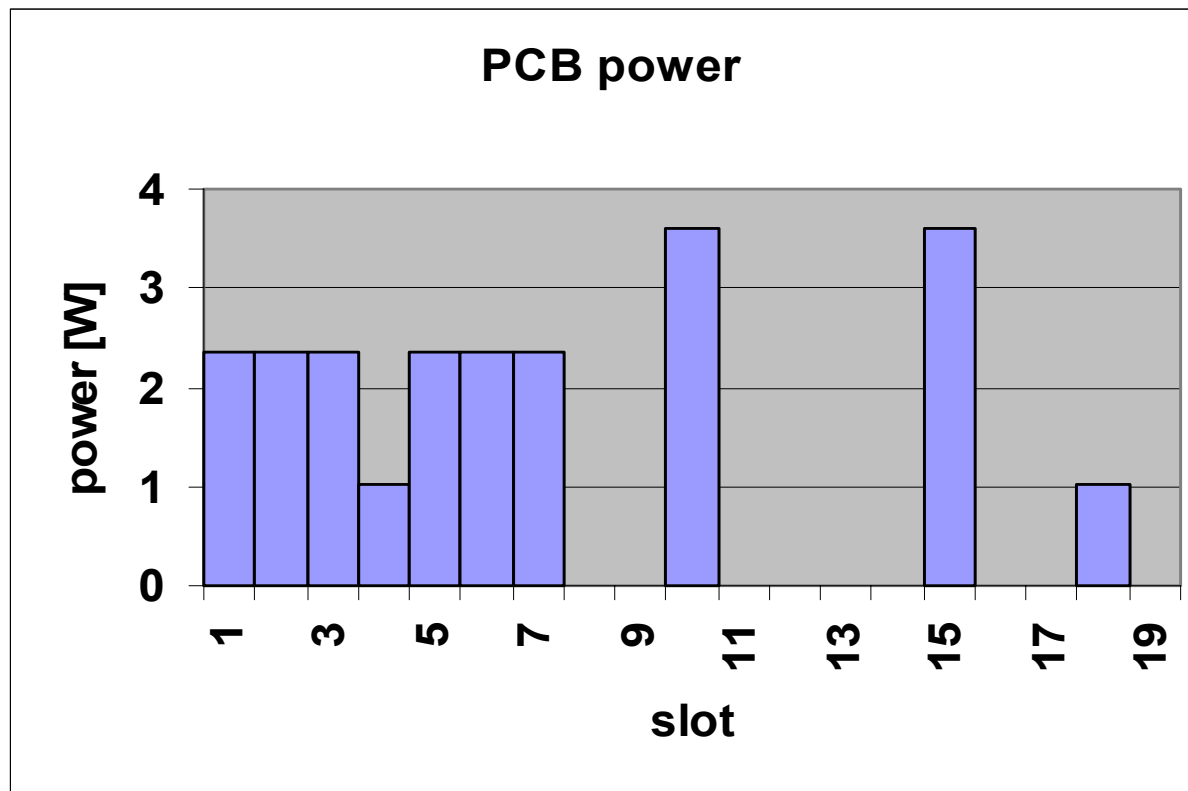

R

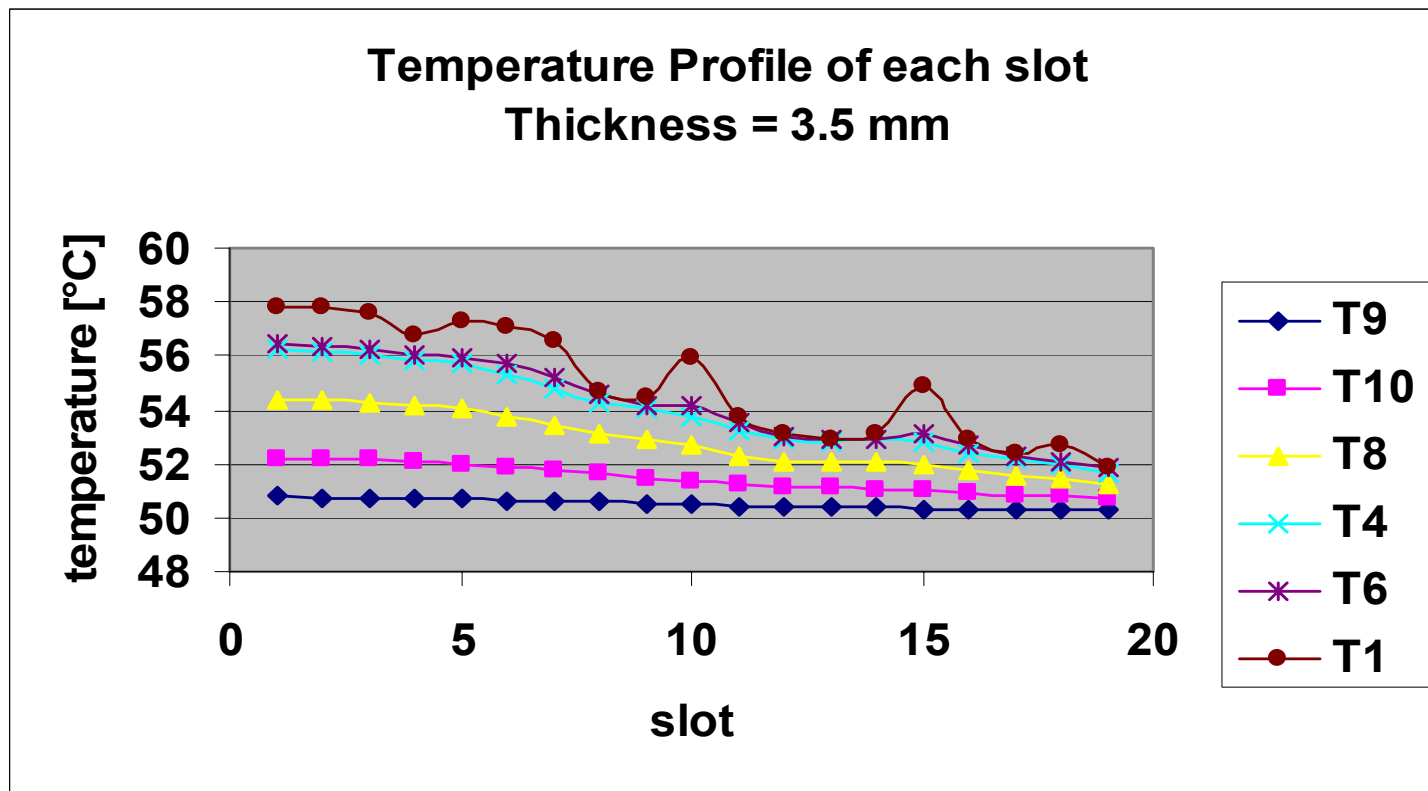

R

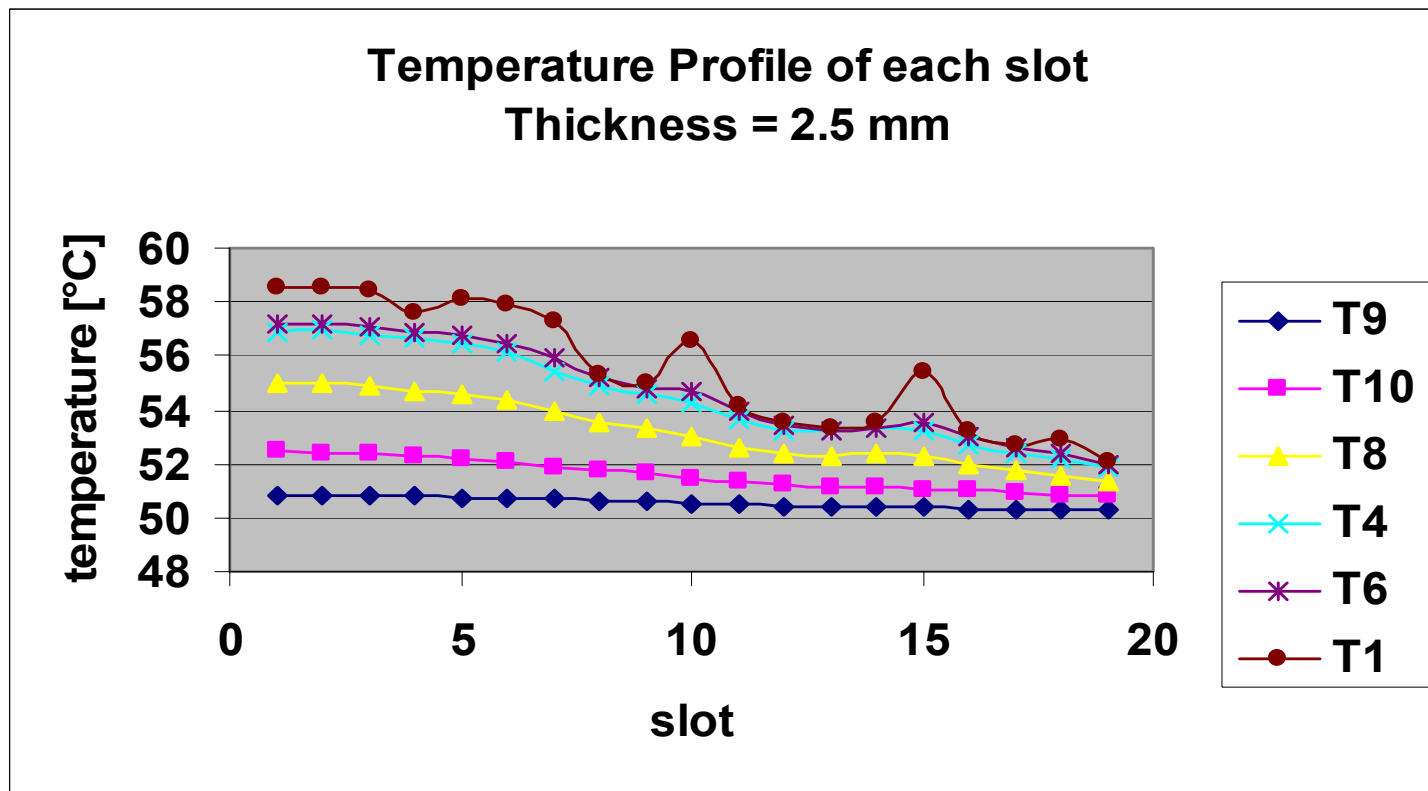

R - CRATE

mass saving per wall (total is double)

R	19 slots	quantity:	2
	SP2= 2.5 mm	saving:	1.0 g per slot
	SP3= 6.0 mm		
	SC= 2.5 mm	saving:	6.5 g per slot
	SP6= 3.0 mm	saving:	0.4 g per slot
	SP10= 3.0 mm	saving:	0.2 g per slot
	SC2= 8.0 mm	saving:	2.4 g per slot
		total:	10.5 g per slot
@58.6°C	-200 g each		-401 g TOTAL

E

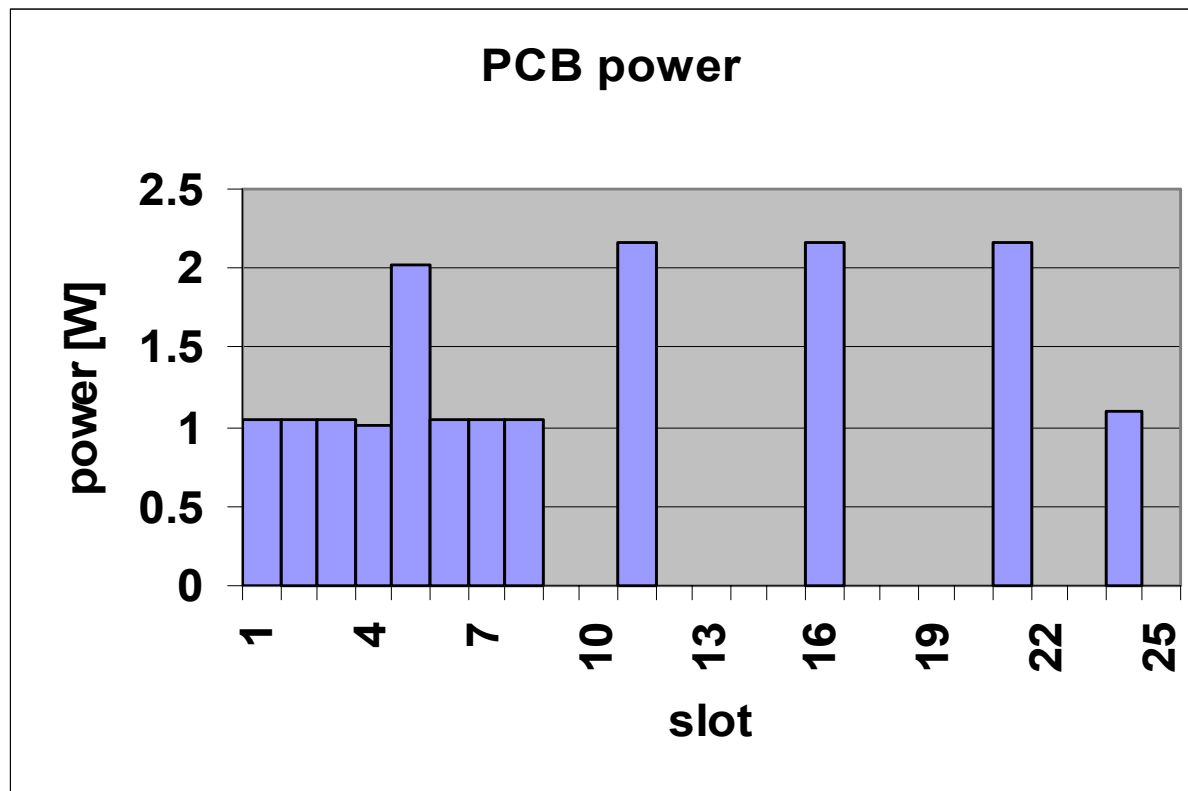

E

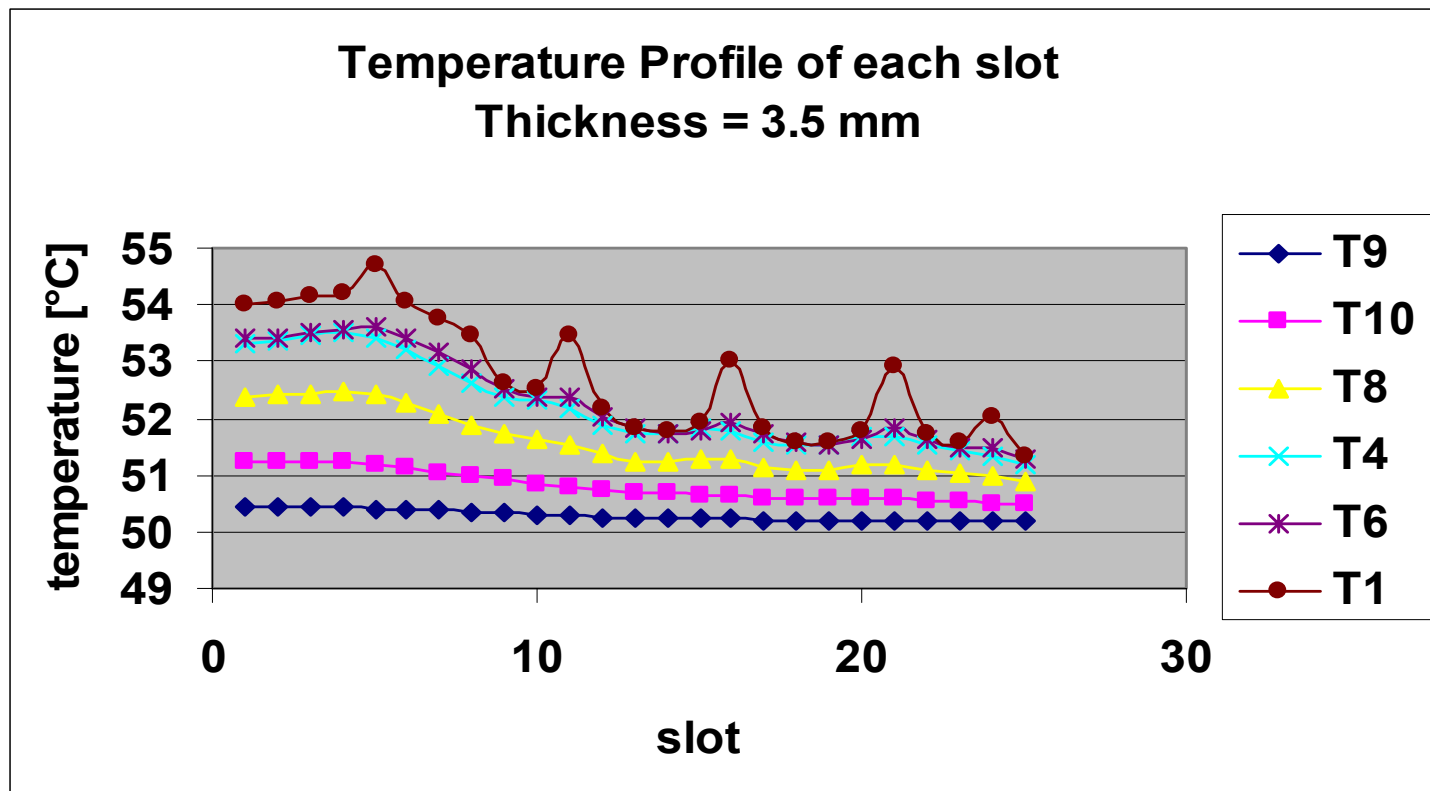

E

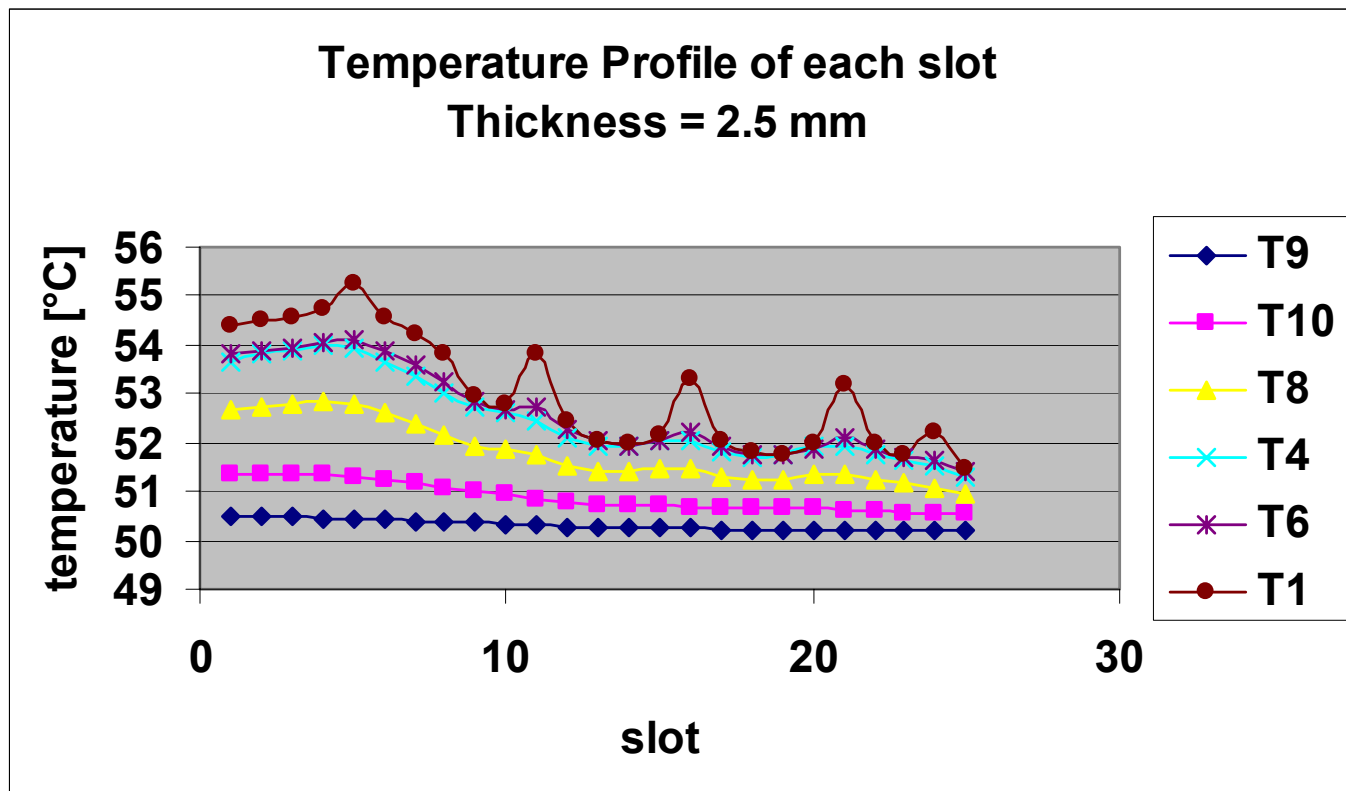

E - CRATE

mass saving per wall (total is double)

E	25 slots		quantity:	2
	SP2=	2.5 mm	saving:	1.0 g per slot
	SP3=	6.0 mm		
	SC=	2.5 mm	saving:	6.5 g per slot
	SP6=	3.0 mm	saving:	0.4 g per slot
	SP10=	3.0 mm	saving:	0.2 g per slot
	SC2=	8.0 mm	saving:	2.4 g per slot
		total:	10.5 g per slot	
@55°C	-264 g each		-527 g TOTAL	

SUMMARY

Name	Number of Slots	Mass savings	Number @ ram	Number @ wake	Saving @ ram	Saving @ wake	Total Saving
T	21	-222	4	4	-886.0	-886.0	-1772.1
S	12	0	2	2	0.0	0.0	0.0
U	21	-222	1	1	-221.5	-221.5	-443.0
M	12	0	1	0	0.0	0.0	0.0
JT	15	-236	1	0	-235.5	0.0	-235.5
UG	12	-202	0	1	0.0	-201.9	-201.9
TI	9	-155	0	1	0.0	-134.6	-134.6
MB	15	0	1	0	0.0	0.0	0.0
J	22	0	1	0	0.0	0.0	0.0
R	19	-200	1	1	-200.4	-200.4	-400.8
E	25	-264	1	1	-263.7	-263.7	-527.4

THESE FIGURE MUST BE DOUBLED to account for two main walls per crate

Boxes out of specs.
(but < 60°C)

grandtotal: -3715.3
grandtotal: -1340.5

New radiator model

- Heat pipes current layout
- Refined nodalization
- Updated thermal conduction through Heat Pipes

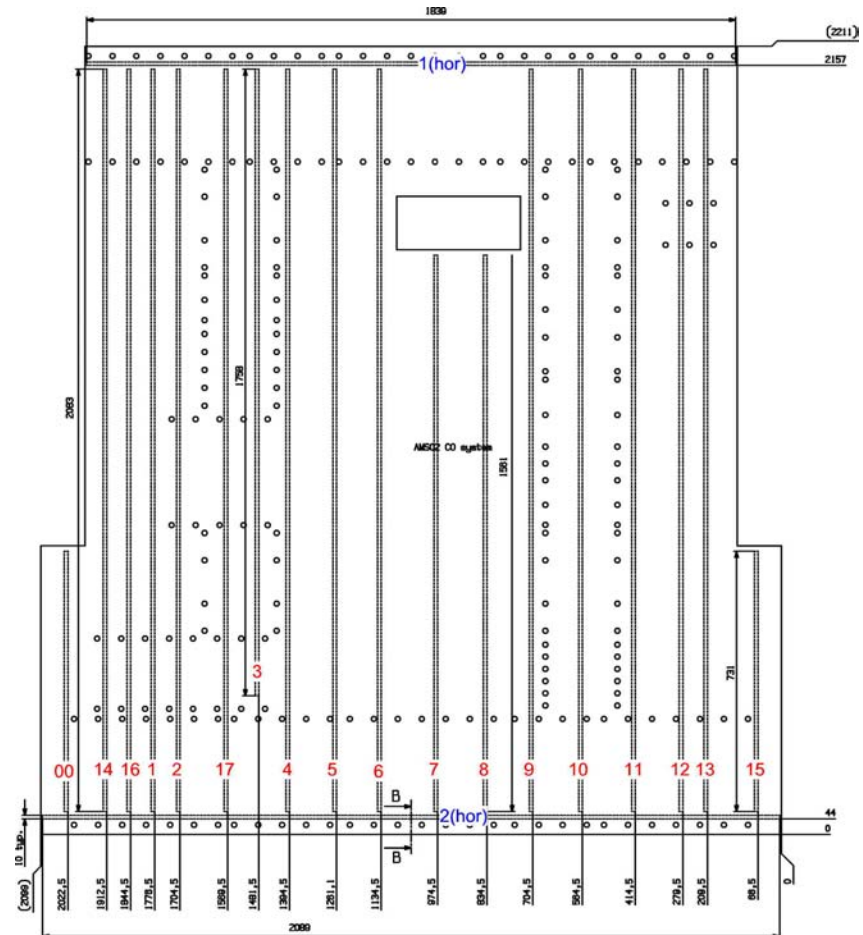

Radiator temperature map

Box	Temperature [°C]
T1	50.028
S1	44.994
U1	39.295
UG1	37.219
T2	39.727
TPD1	44.913
SPD1	41.001
TTPD1	40.516
TT	39.027
TPD3	41.953
TPD2	36.341
UPD1	34.726
UGPD1	34.243
SPD2	34.59
TPD4	35.648
T3	44.184
PDB1	47.305
S2	42.905
T4	39.361

Box	Temperature [°C]
T1	41.617
S1	40.093
U1	38.805
M1	41.363
T2	39.497
TPD1	43.744
SPD1	40.881
JT1	36.07
TPD3	44.188
CCEB	53.832
TPD2	41.84
UPD1	38.805
MPD1	40.172
SPD2	40.19
TPD4	40.559
T3	40.017
JPD1	37.474
J1	33.51
S2	37.549
T4	35.972

WAKE

RAM

Nominal temperatures (as per thermal ICD)

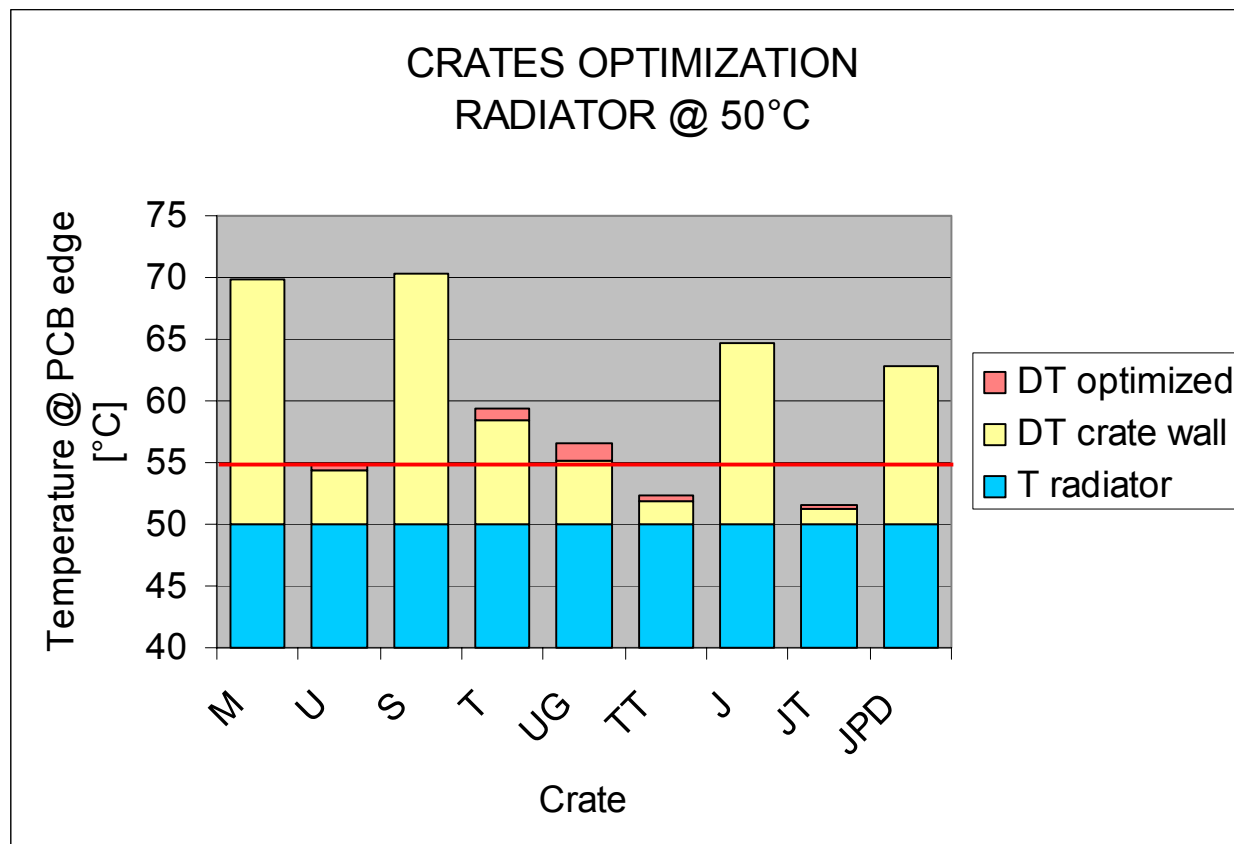

Acceptance temperatures (= nominal +5°C)

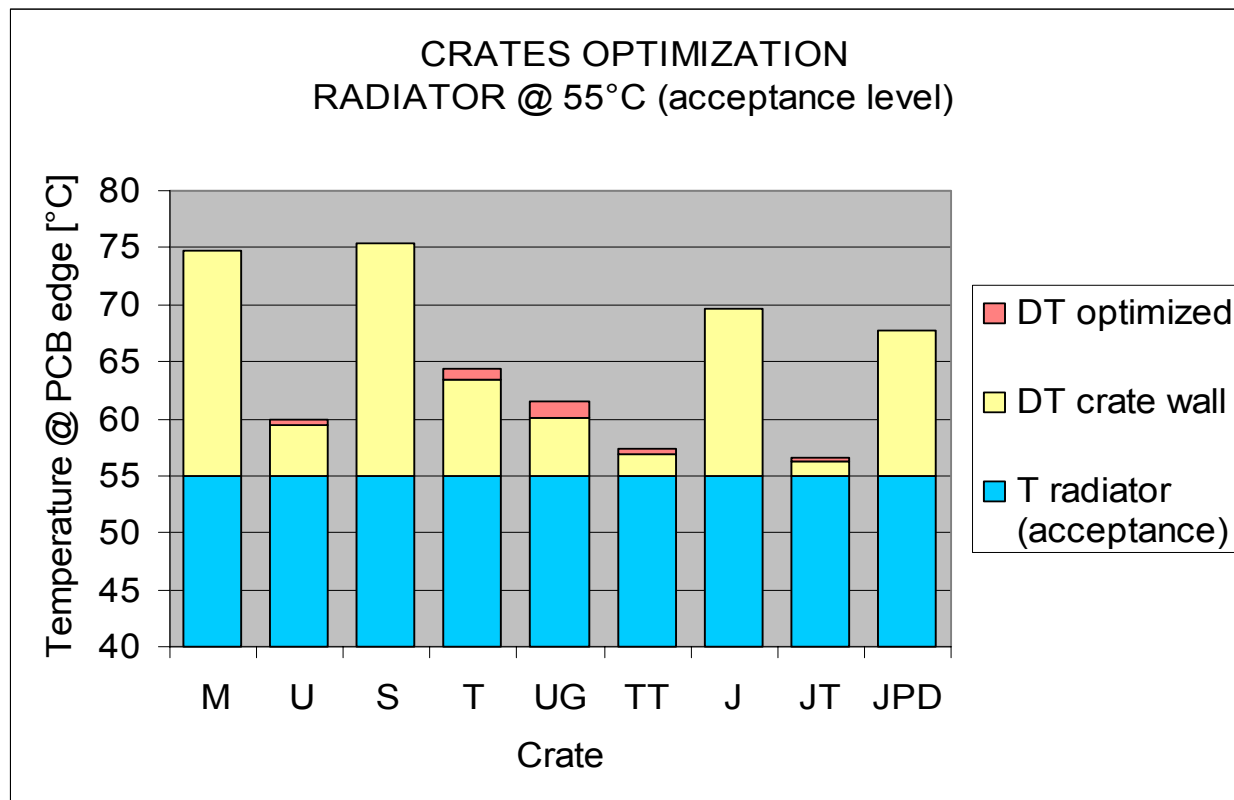

On-orbit temperatures (thermal simulation results)

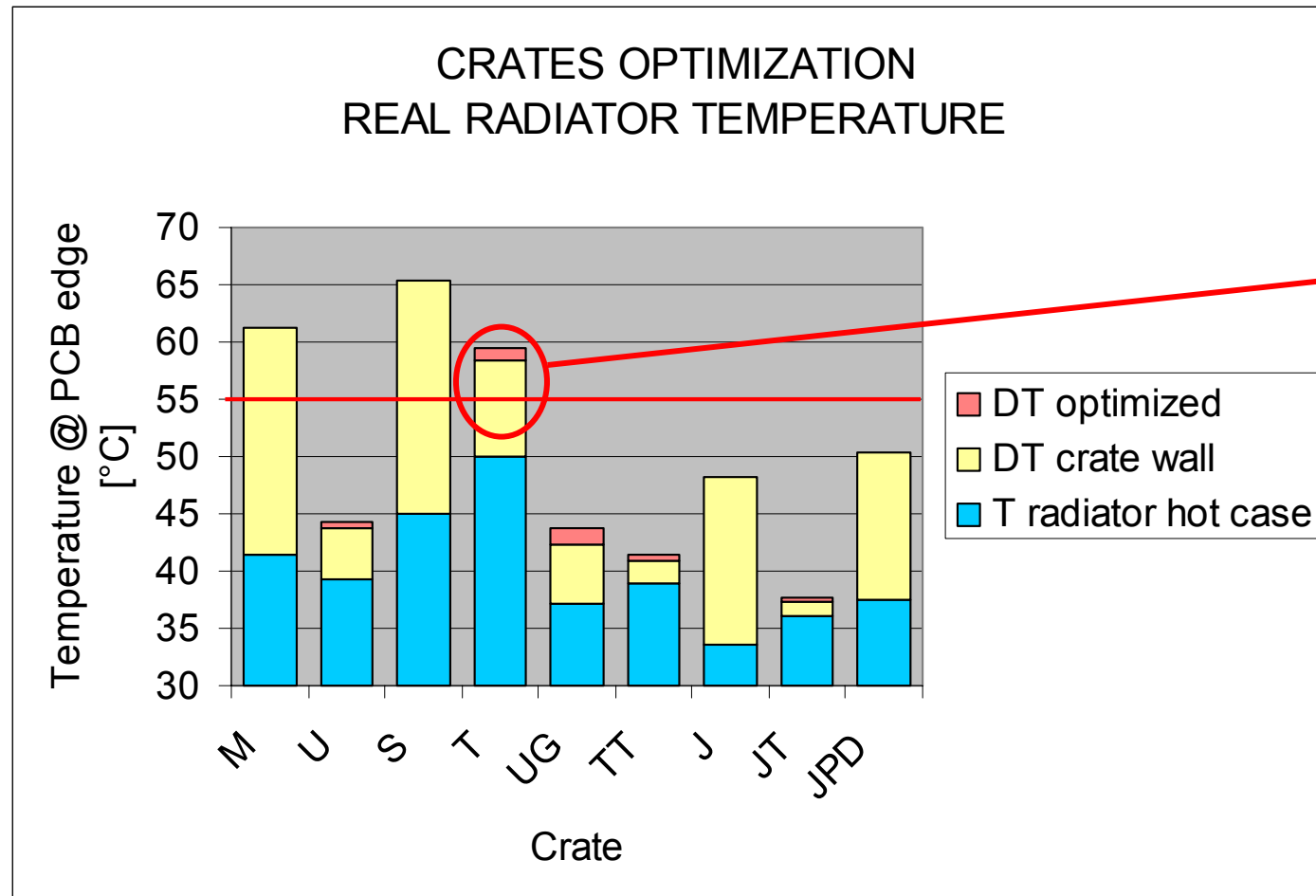

Out of specs, but allowing 1.7 kg savings

OPEN POINTS

- How far can we push the current temperature limits on card edges?
 - “Nominal” (now +55°C at board level)
 - Acceptance (now +60°C at board level)
- IF ALL THE CRATES ARE QUALIFIED AT +55°C, there is no problem (board might experience edge temperatures up to 70°C)

OPEN POINTS (2)

- Is it possible to accommodate PCBs in a different way?
- How to proceed with high-power boards/high power crates?

TPG

- Under investigation the chance to use TPG (thermal pyrolytic graphite) to increase thermal path
- TPG offers high conductivity in planar directions (~ 1700 W/K, vs. 155 W/K for Aluminum)
- Low out-of-plane conductance (~ 15 W/K)
- TPG density ~ 2260 kg/m³ (2700 for Al)

TPG results (preliminary)

- Reducing the thickness of the main wall, and replacing it with the same amount of TPG:

Crate main wall sections:

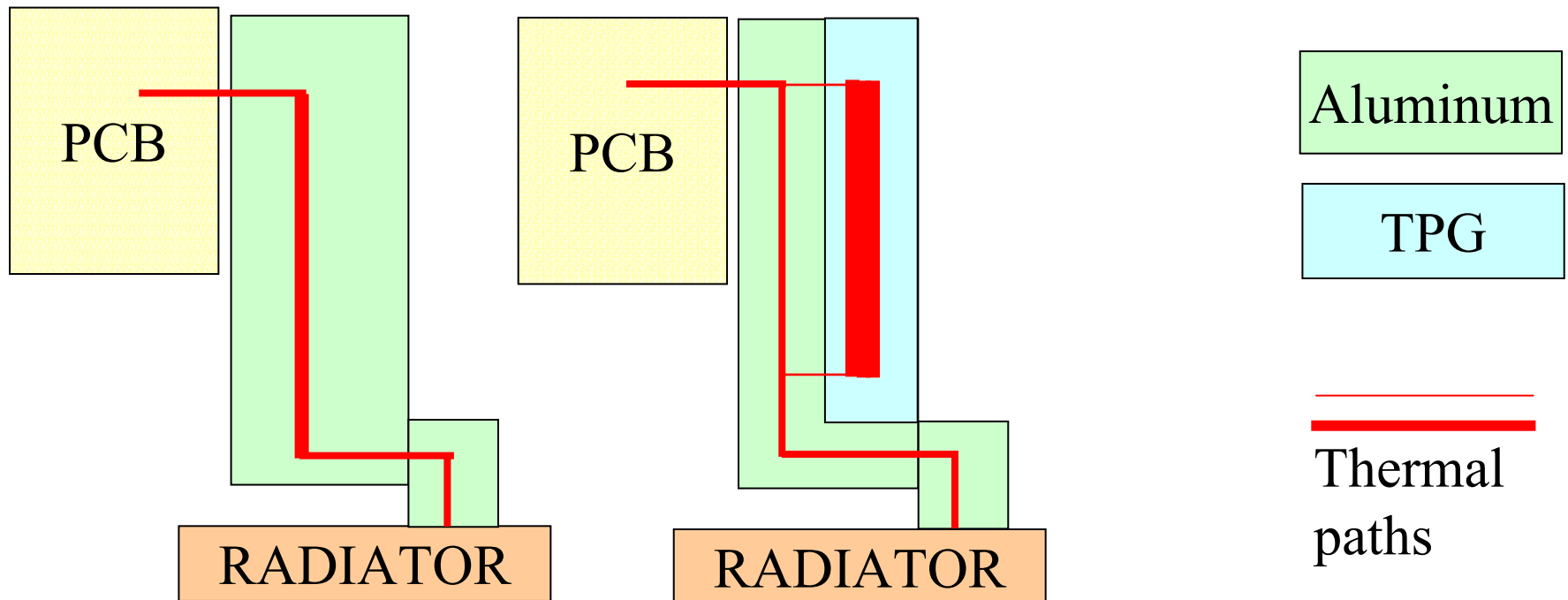

TPG results (preliminary)

- The total thermal path from center wall to radiator changes from:
 - **0.10 W/K** (3.5 mm Aluminum ONLY)
 - **0.16 W/K** (2.0 mm Aluminum + 1.5 TPG)
- Same thickness, slightly less weight,
~ +60 % conductance
- Note: no transversal conduction to neighbouring cards considered in this evaluation

TPG open points

- Mechanical feasibility (waiting for supplier feedback)
- Fixation details
- Better modelling
 - nodalization refining
 - transversal effects between neighbouring slots