

# Crates thermal design

7 May 2002

M. Molina

# Table of Content

- Crates thermal modelling
- Working together with NSPO, a short report
- Temperature ranges

# J crate

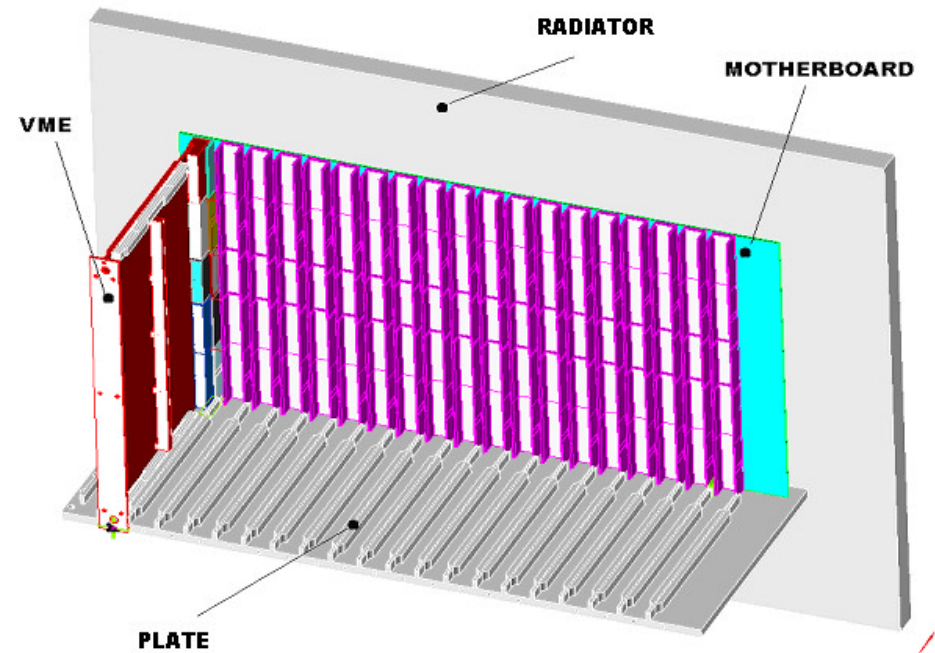
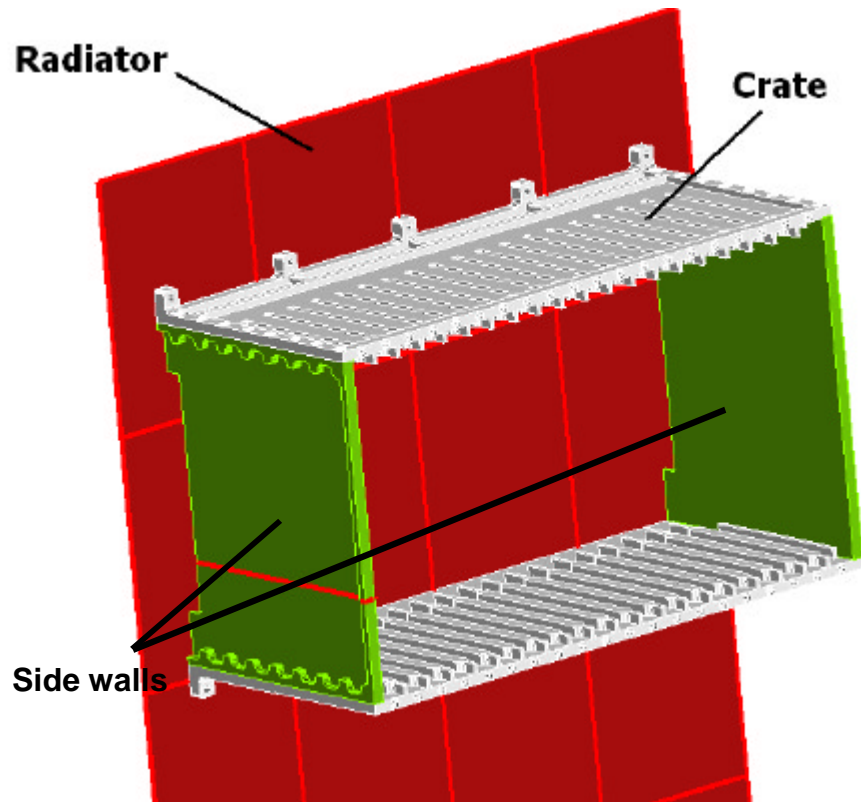

# J CRATE THERMAL MODEL

ALUMINIUM plates (in submodels BOARD1-BOARD24)

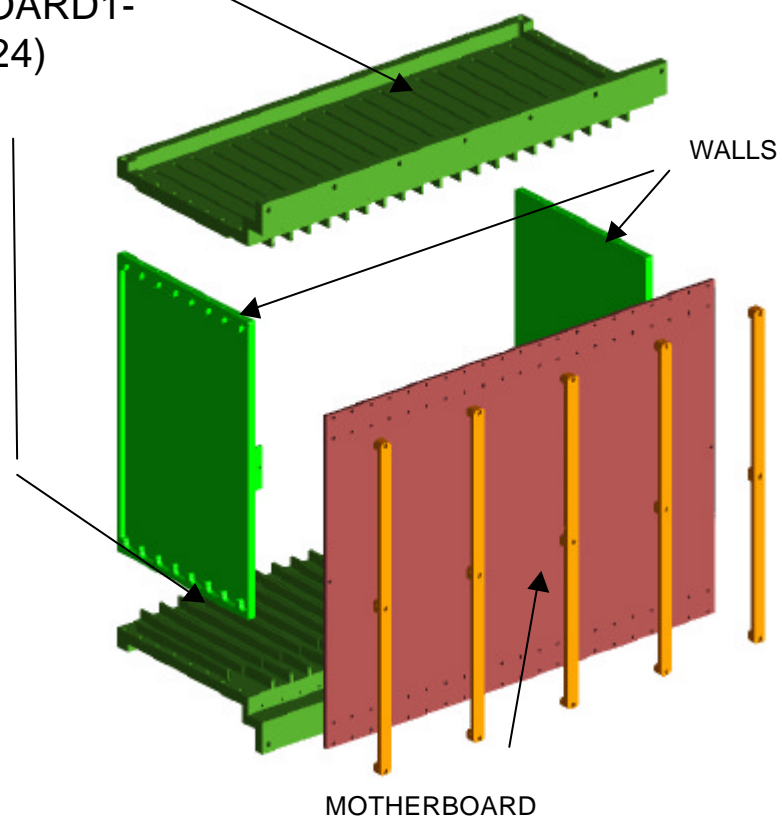

SUBMODEL NAME	DESCRIPTION	NODES NUMBER
SCH1-SCH24	represents a PC board and part of Aluminium	20 (for each PC board)
WALL	wall sides	4
MOTH	motherboard	1
P	magnetic shield	25
MLI	MLI	5
RAD	radiator	1
COLLEG	links between wall nodes and 1st and 24th PC boards	8
CASE19	merat nodes	5
OUTMOD	to format output data	0
<b>Total node number</b>		<b>529</b>

# J crate nodal breakdown (boards level)

## PC board #1 (lower part)

### NODES:

- **1000**: centre of card
- **1**: lower edge of card.
- **6; 5; 4; 3; 2; 8; 10; 9**: lower aluminium plate grooves
- **2; 6**: card guides (interface to adjoining submodels)

### CONDUCTORS:

nodes	conductors
2-6	Aluminium plate
2-3	Aluminium plate
4-3	Aluminium plate
5-4	Aluminium plate
5-6	Aluminium plate
1-6	card retainer contact conductance board equivalent conductance

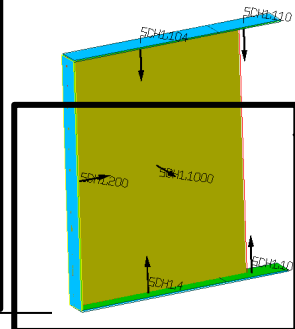
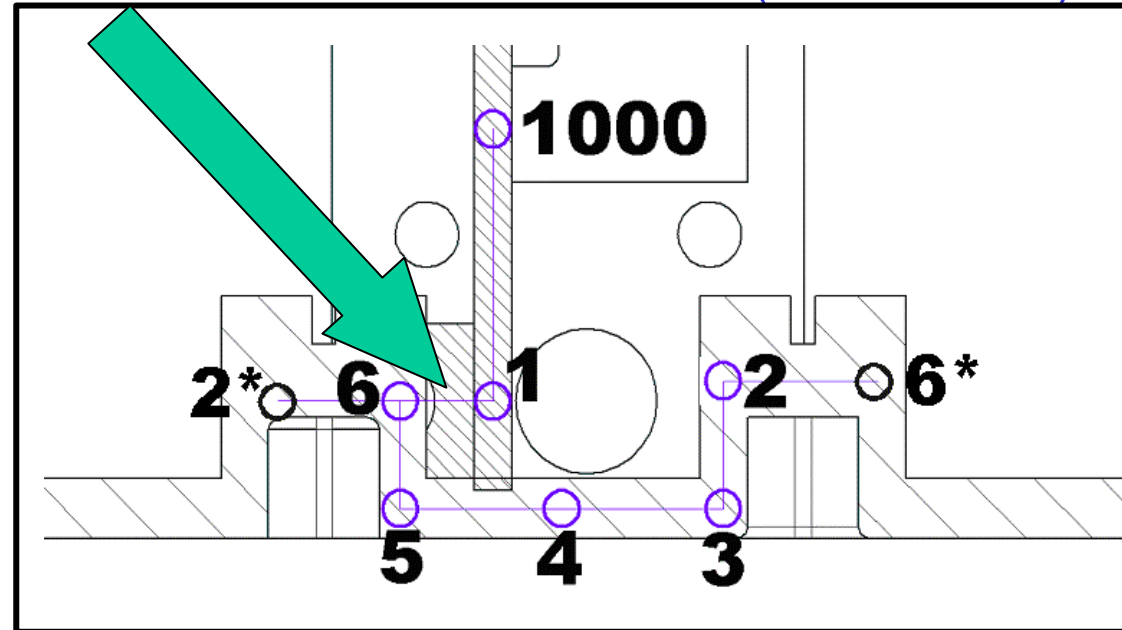

### UPPER PART:

- **101**: upper edge of card
- **106; 105; 104; 103; 102; 108; 110; 109**: upper aluminium plate grooves
- **102; 106**: card guides

# J crate nodal breakdown (aluminium plate)

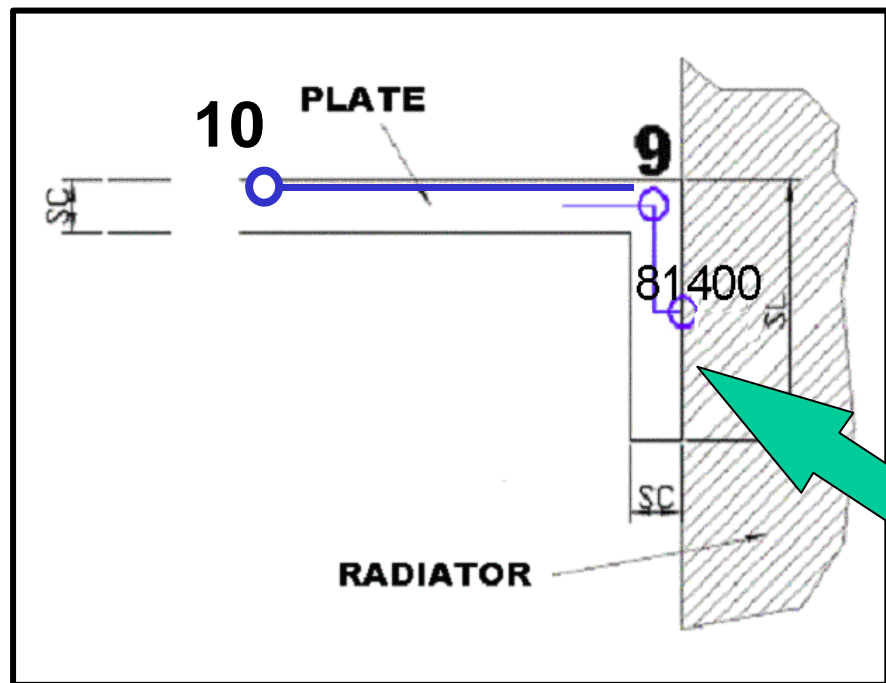

## aluminium plate

(thermal path from node in the middle of the board up to radiator)

- **9**: L-shaped foot
- **81400**: radiator node

**conductance 9-81400**: contact conductance improved by means of interface filler (CHO-TERM)

# JPD crate

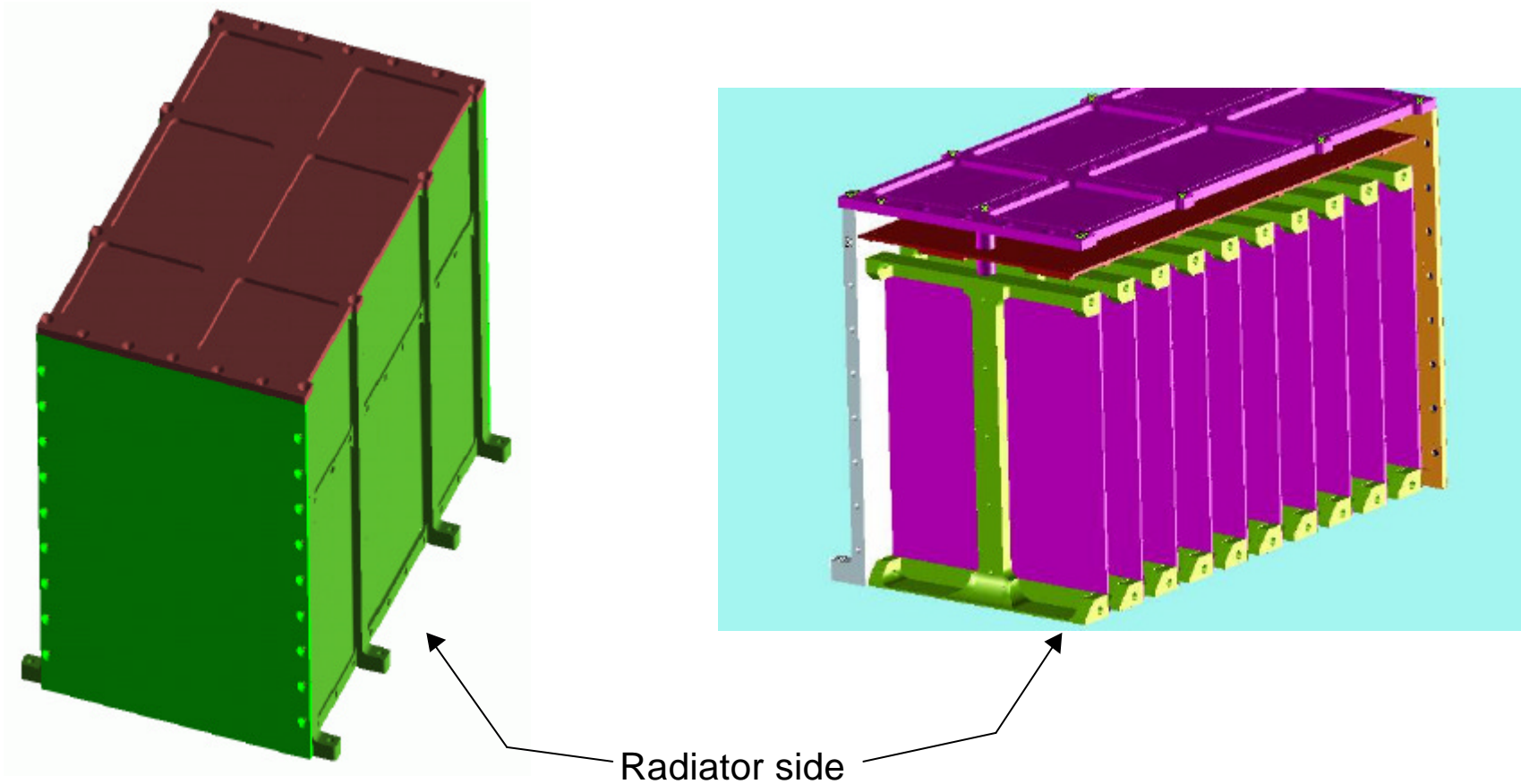

# JPD crate submodels

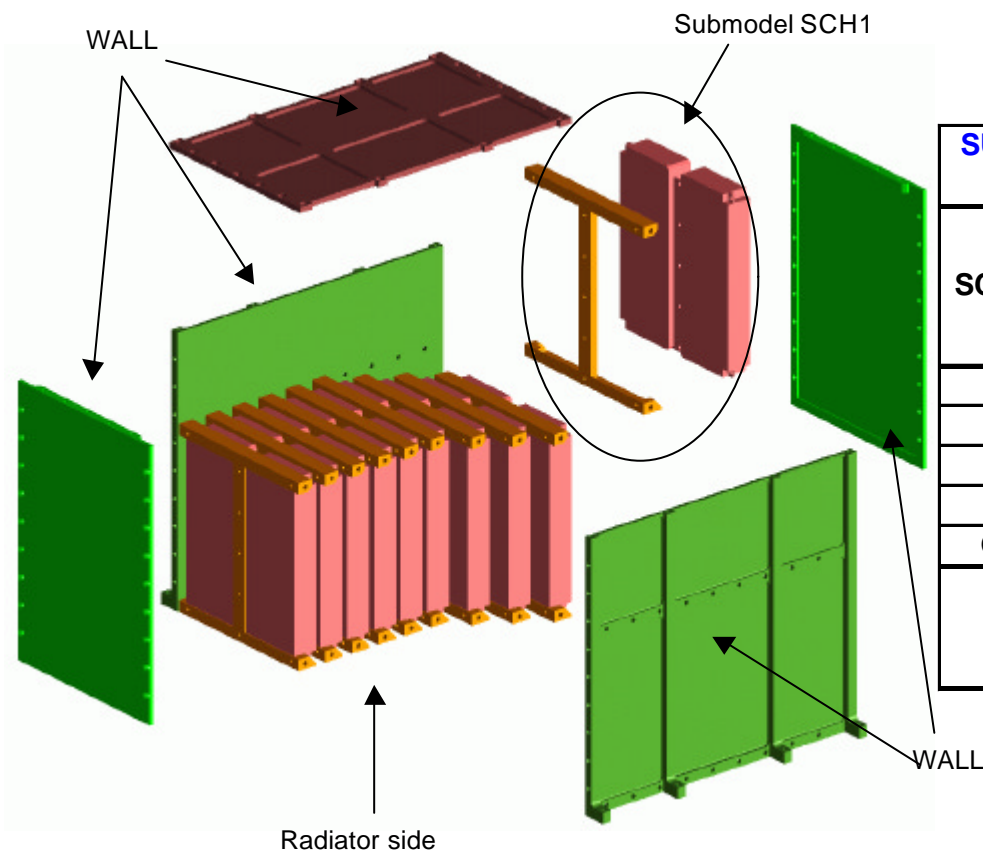

SUBMODEL NAME	DESCRIPTION	NODES NUMBER
SCH1-SCH12		12 (for each PC board)
WALL	wall sides	5
MLI	MLI	5
RAD	radiator	1
CASE19	merat nodes	5
OUTMOD	to format output data	0
<b>Total node number</b>		<b>160</b>

# JPD crate nodal breakdown (board level)

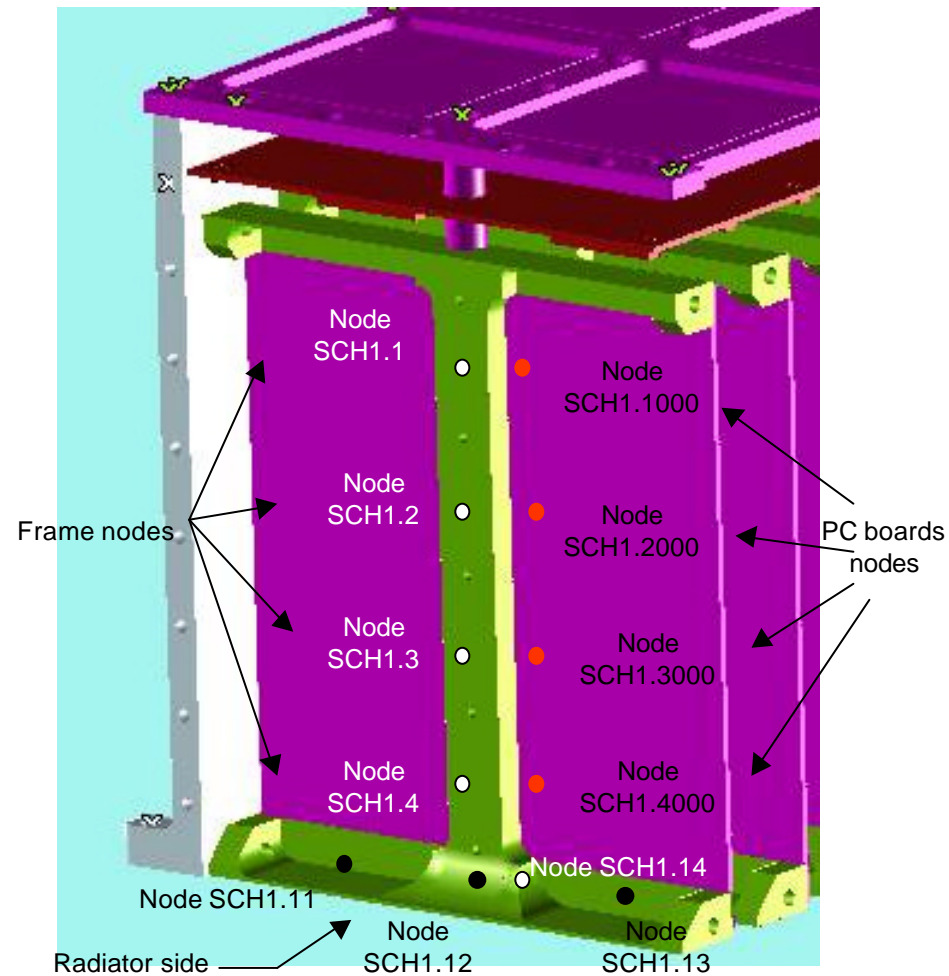

# CRATES thermal design and verification (CGS + NSPO)

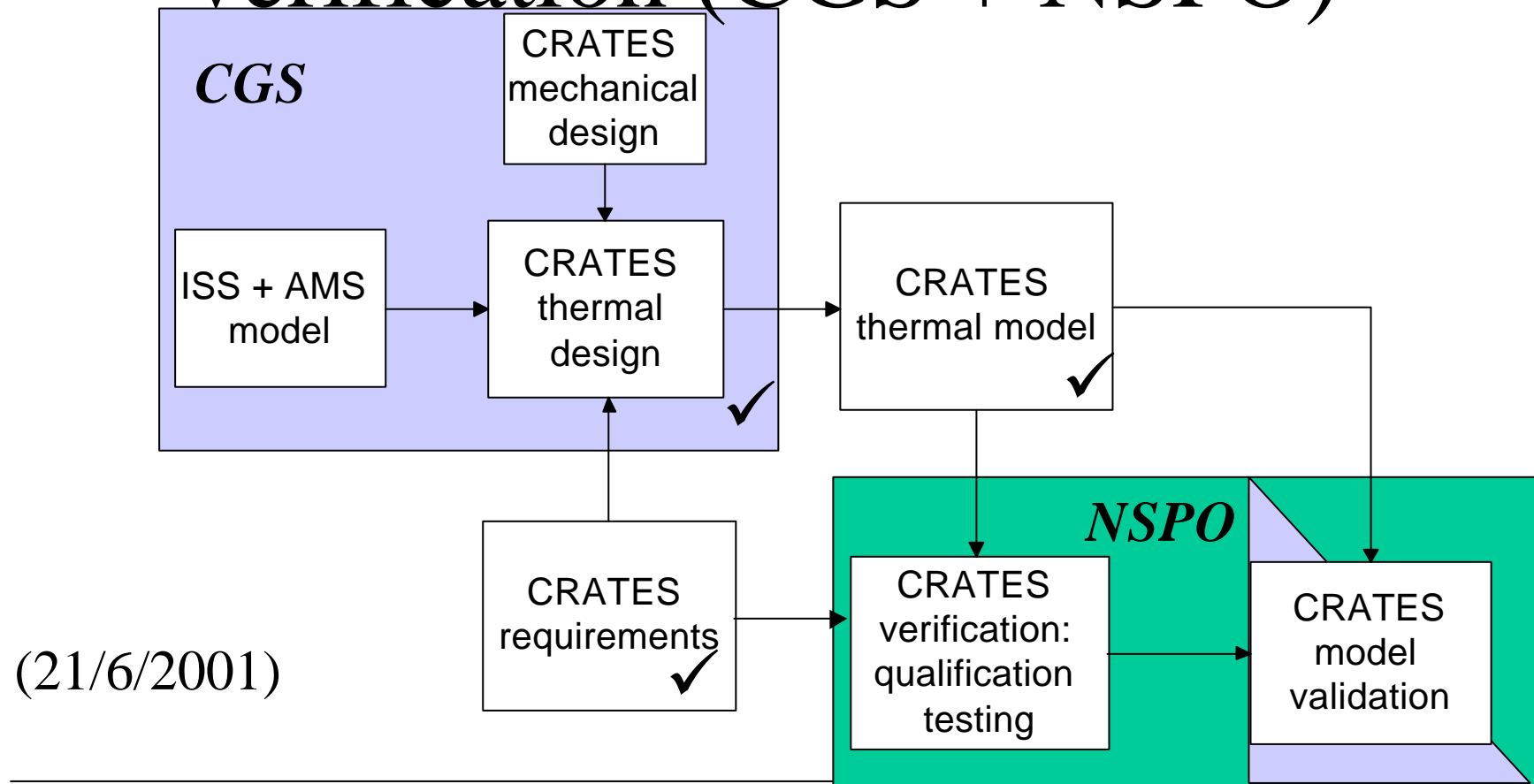

## Crates verification (NSPO+CGS)

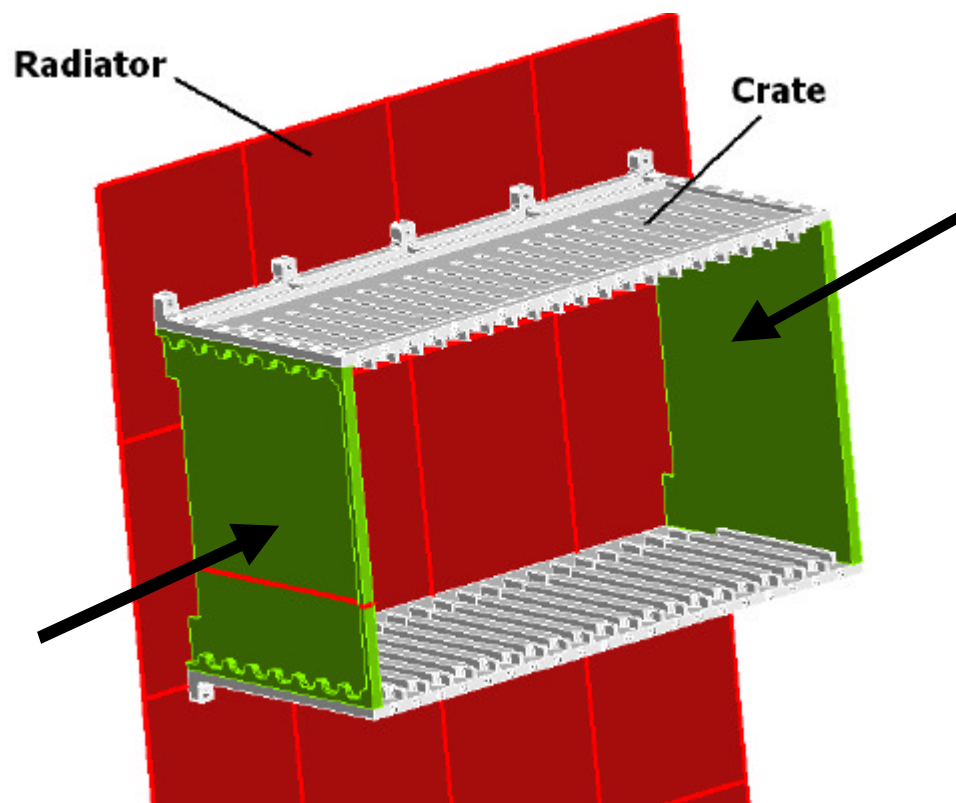

Side walls (built specifically for the tests purposes) will be temperature controlled during thermal cycling and thermal balance tests.

# NSPO and CGS working together

- In a dedicated meeting NSPO and CGS went through modelling parameters identifying the more uncertain ones.
- During the meeting NSPO got information that, integrated with a few more to be provided within next Friday, will allow to run test prediction
- The first crate considered will be J-crate
- The correct understanding of the J-crate model will speed up all the other crates TEST prediction

---

---

# TEMPERATURE RANGE

“So I would like to formally request that the lower operational limit for all the crate and box electronics mounted on radiators, including "non-standard" boxes, be adjusted from -30 C to -20 C”

M. Capell, 25<sup>th</sup> April 2002

# Temperature range

Crates temperature  
range

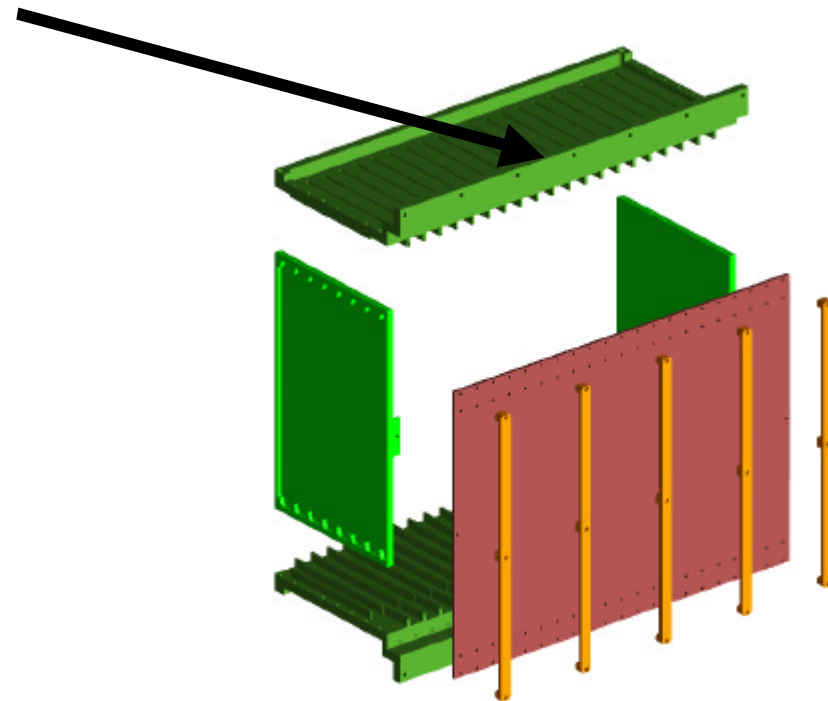
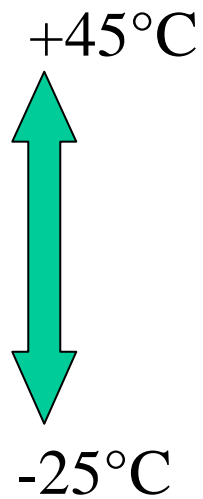

# Temperature range

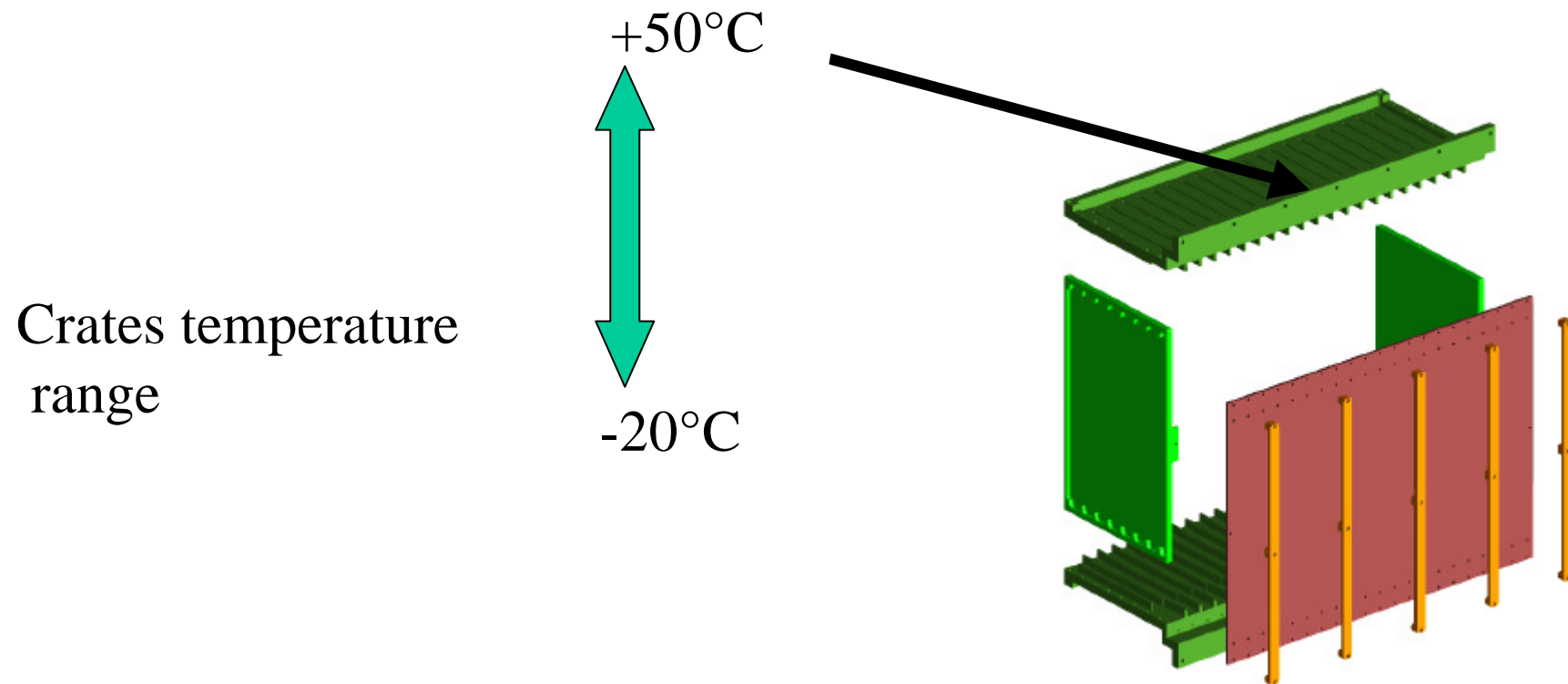

# Board edge temperature range

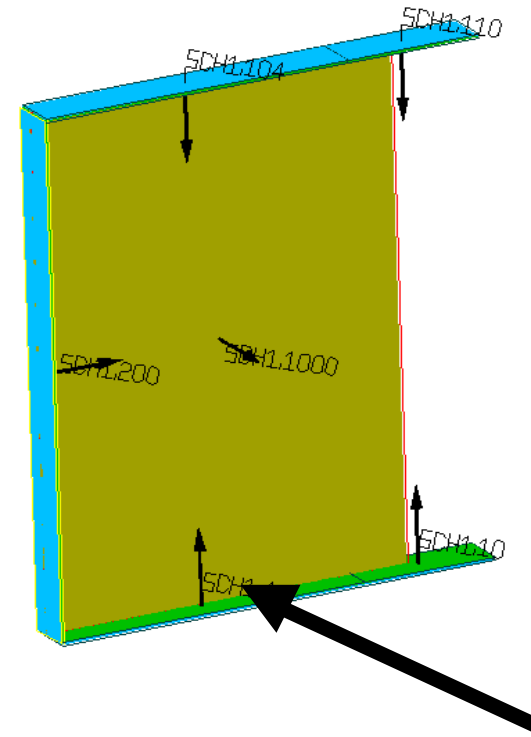
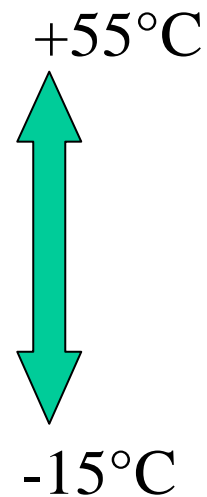

10 °C higher than crate foot temperature

# Board edge temperature range

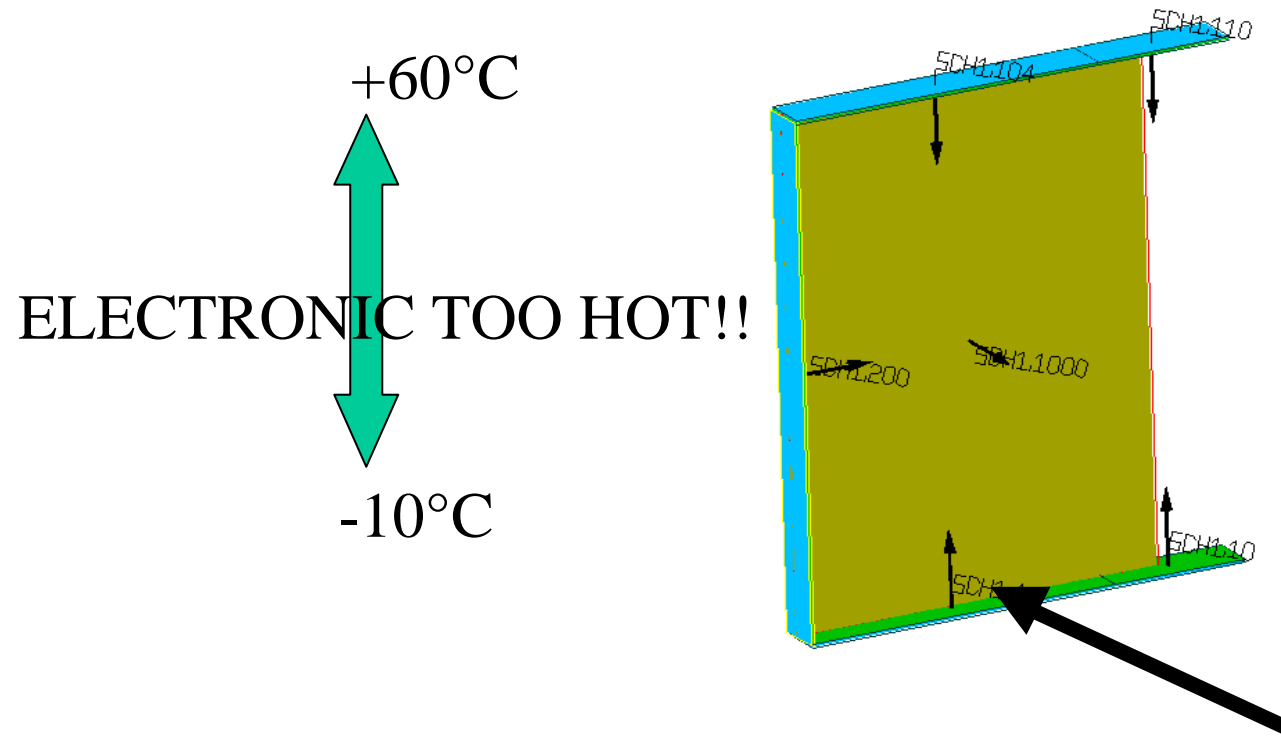

# Crates Temperature range

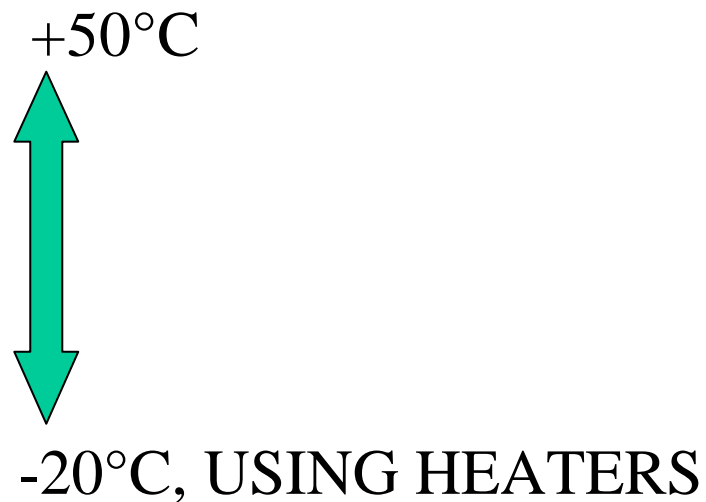

# AMS 02 –Thermal Control System Design

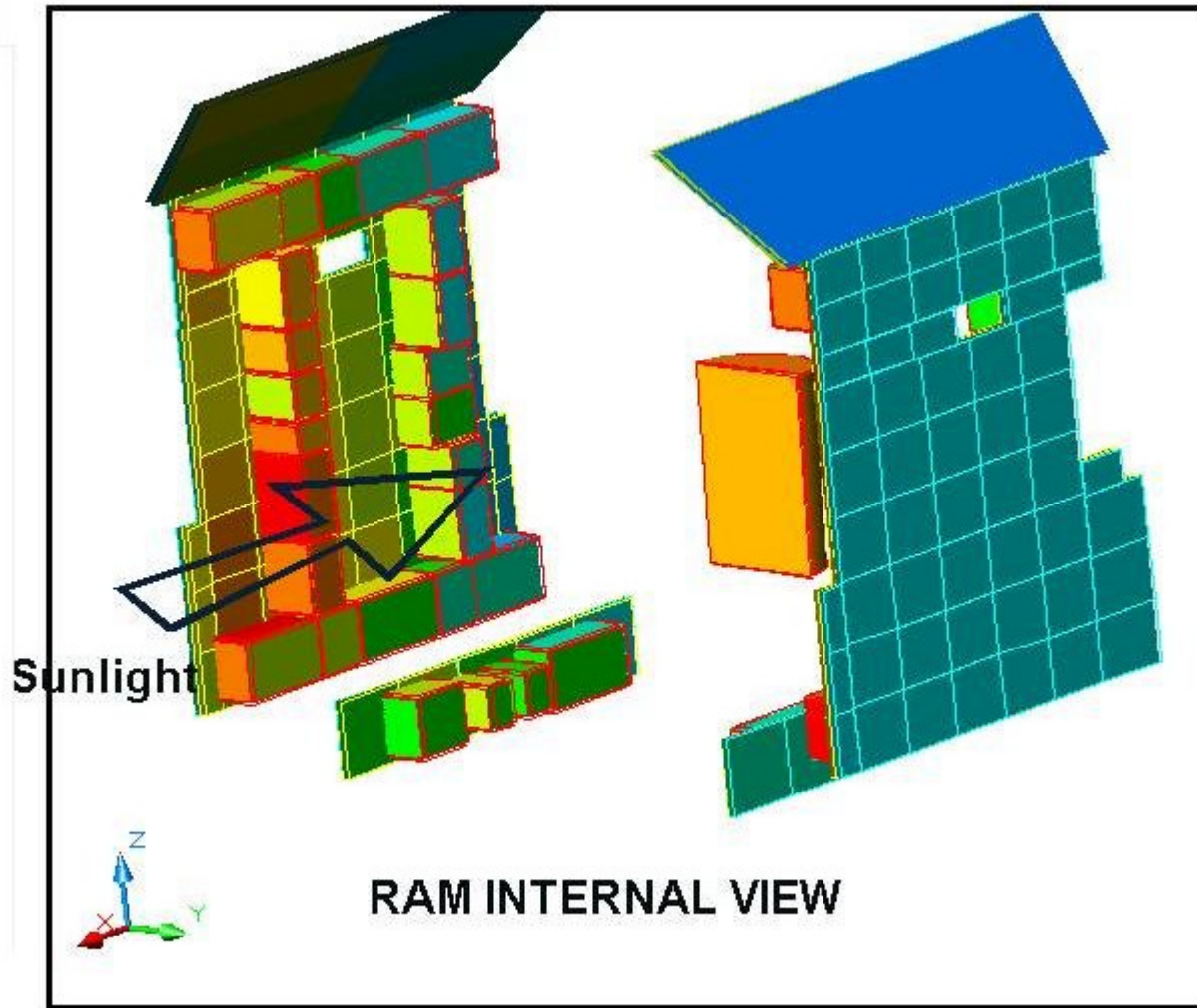
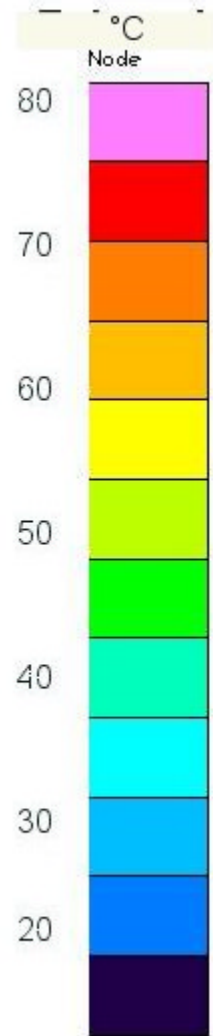

# AMS 02 –Thermal Control System Design

