





-ESCG-

1. PROJECT CODE SA-AMS		2. JPIC CODE AMS		TASK PERFORMANCE SHEET			
				NASA - LYNDON B. JOHNSON SPACE CENTER			
TYPE	A	CONFIGURATION CHANGE	<input checked="" type="checkbox"/>	4. TPS NO. 2A0720178		5. PAGE 1 OF 6	
		PERMANENT	<input checked="" type="checkbox"/>	6. MOD SHEET(S) NUMBER(S)		7. ORG.	8. SYSTEM
	B	NONCONFIGURATION CHANGE	<input type="checkbox"/>			EA	AMS
10. PART NAME Vertex Bracket Match Drill Assembly			11. PART NO./DRAWING NO. SFG38119521-301		12. SERIAL/LOT NO. N/A		13. TIME/CYCLE/SHELF LIFE <input checked="" type="checkbox"/> YES <input type="checkbox"/> NO
14. APPLICABLE DOCUMENTS N/A			15. CONTRACT NO./JOB NO. NNJ05HI05C		16. HAZ. TEST <input type="checkbox"/> YES <input checked="" type="checkbox"/> NO		17. ENG. EVAL. <input type="checkbox"/> YES <input checked="" type="checkbox"/> NO
18. SHORT TITLE OF TPS Vertex Bracket Match Drill Procedure						19. ADP UPDATE <input type="checkbox"/> YES <input checked="" type="checkbox"/> NO	
20. OPER. SEQ. NO.		21. OPERATIONS (Print, Type, or Write Legibly)				VERIFICATION	
		 7-30-07				22. TECH	
1.		<p>Open this TPS.</p> <p>The Jacobs Project Engineer on site has the option to reorder the steps in order to facilitate the logistics of moving around this large hardware.</p> <p>All hardware removed during the performance of this TPS shall be bagged and tagged to identify their P/N and S/N or Lot# if applicable.</p> <p style="text-align: center;">NOTE: THE LUSS SHIPPING COVER HAS ALREADY BEEN REMOVED</p> <p><u>PREPARING THE LUSS FOR MATCH DRILLING</u></p>					
2.		<p>Disassemble the LUSS, SEG39135758-302, from Shipping Fixture by removing the eight (8) fasteners, Screw Socket Head, NAS1351N6LB88 (CI), and flat washers, NAS1149E0663R (CI), item 17 and 23 in Figure-1, for four corners. Place the fasteners in the marked bag for identification.</p> <div style="border: 2px solid black; padding: 5px; width: fit-content; margin: 10px auto;"> <p style="font-size: 24px; font-weight: bold; text-align: center;">ORIGINAL</p> <p style="text-align: center;">Return to Bldg. <u>10</u></p> <p style="text-align: center;">Rm. <u>114</u> QARC</p> </div>				 8-20-07	
24. ORIGINATOR John Heilig 			DATE 7-30-07	25. FINAL ACCEPTANCE STAMP AND DATE			
APPROVALS (Printed or Typed and Signed)							
26. PROJECT ENGINEER John Heilig 			DATE 7-30-07	27. QUALITY ENGINEER Steve Caldwell 			DATE 7-30-07
28.				29.			
30.				31.			

TASK PERFORMANCE SHEET
 CONTINUATION PAGE
 NASA - LYNDON B. JOHNSON SPACE CENTER

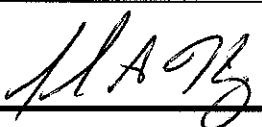
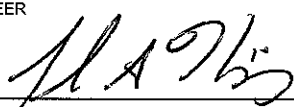
4. TPS NO.

2A0720178

6. MOD NO.

20. OPER
SEQ. NO.

21. OPERATIONS
(Print, Type, or Write Legibly)

VERIFICATION

22. TECH

23. QA/DV

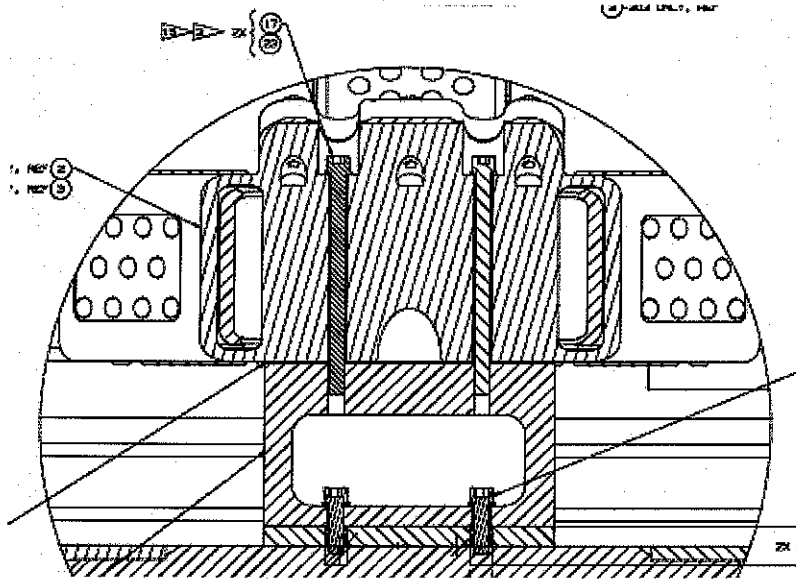

Figure-1

CAUTION: DO NOT DAMAGE FLIGHT HARDWARE DURING LIFTING AND MANEUVERING OF THE LUSS

3. Using 4 straps, strap the LUSS around the four tubes, item 5 and 6 as seen in Figure 2, and attach the other ends of the straps to the crane. Straps should have a WLL of 750 lb each, minimum.

JH
8-20-07

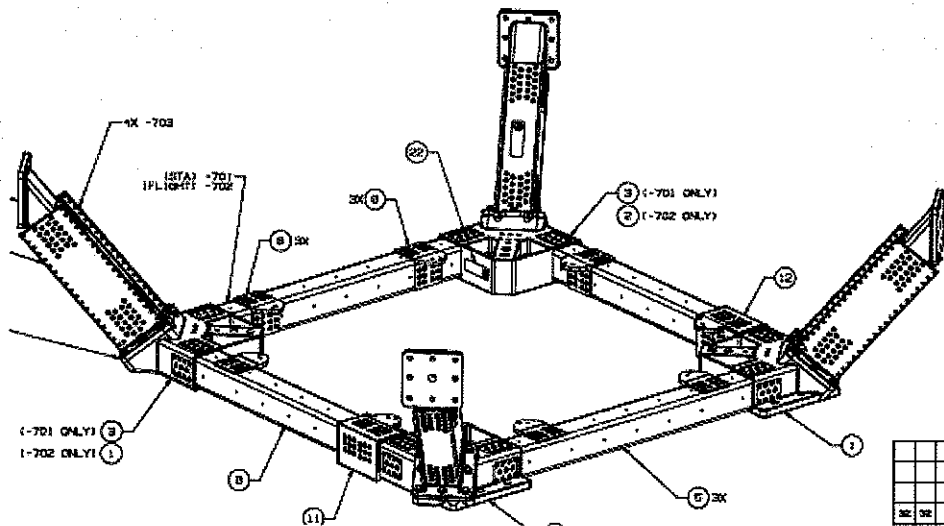

Figure 2

TASK PERFORMANCE SHEET
 CONTINUATION PAGE
 NASA - LYNDON B. JOHNSON SPACE CENTER

4. TPS NO.

2A0720178

6. MOD NO.

20. OPER
SEQ. NO.

21. OPERATIONS
(Print, Type, or Write Legibly)

VERIFICATION

22. TECH

23. QA/DV

4. Lift the LUSS vertically (Slowly) to clear the Shipping Fixture.
5. Place the LUSS, along with the attached ECAL on a wooden surface, or equivalent to allow access to the ECAL mounting bolts shown in Fig. 3.
6. Remove the eight (8) bolts, NAS1960C30, and washers, NAS1587-10C, that fastened the ECAL to the Lower USS-02. See Figure 3. Place the fasteners in the marked bag for identification.

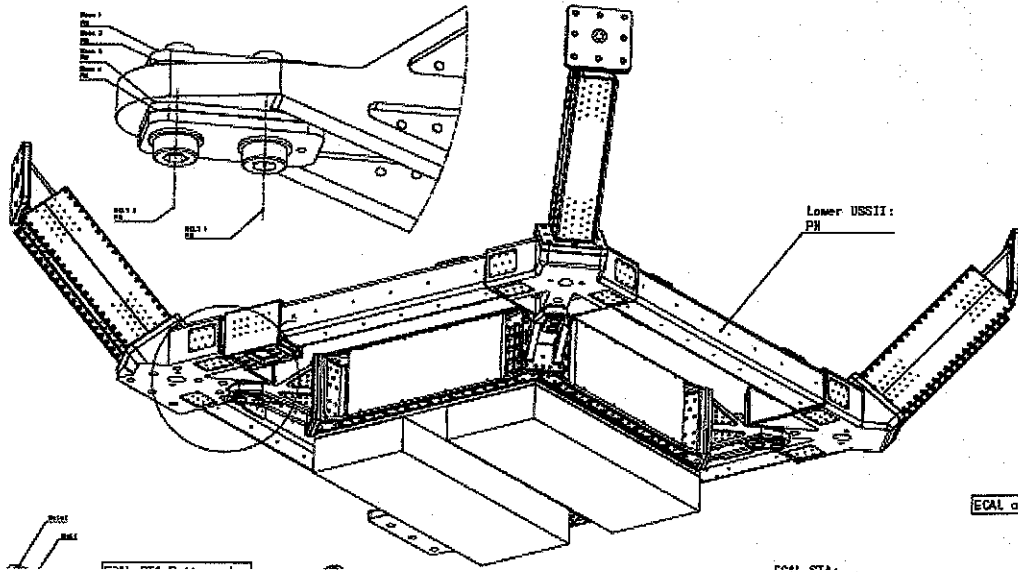

Figure 3

7. Strap the LUSS around the four tubes, item 5 and 6 as seen in Figure 2, and attach the other ends of the straps to the crane. Use same straps as used previously.
8. Slowly raise the LUSS and remove the LUSS from ECAL. Bag and tag the bolts and ECAL shims. Turn the parts over to the ECAL engineer.
9. Place the LUSS onto the wooden supports or table that is at least 30 in. high, 36-46 in wide and about 128 in. or longer, as seen in Figure 4 & 5.
10. Attach the straps to one side on the LUSS.
11. Slowly raise one side of the LUSS vertically by raising the straps. See Figure 4 and 5. If space is limited, the LUSS can be lifted free of the table by crane and manually inverted.
12. Slowly lower the LUSS until it is completely upside down and resting on the wooden supports or equivalent.

JH
8.20.07
JH
8.20.07
JH
8.20.07

JH
8.20.07

JH
8.20.07

JH
8.20.07

JH
8.20.07

JH
8.20.07

JH
8.20.07

TASK PERFORMANCE SHEET
 CONTINUATION PAGE
 NASA - LYNDON B. JOHNSON SPACE CENTER

4. TPS NO.

2A0720178

6. MOD NO.

20. OPER
SEQ. NO.

21. OPERATIONS
(Print, Type, or Write Legibly)

VERIFICATION

22. TECH

23. QA/DV

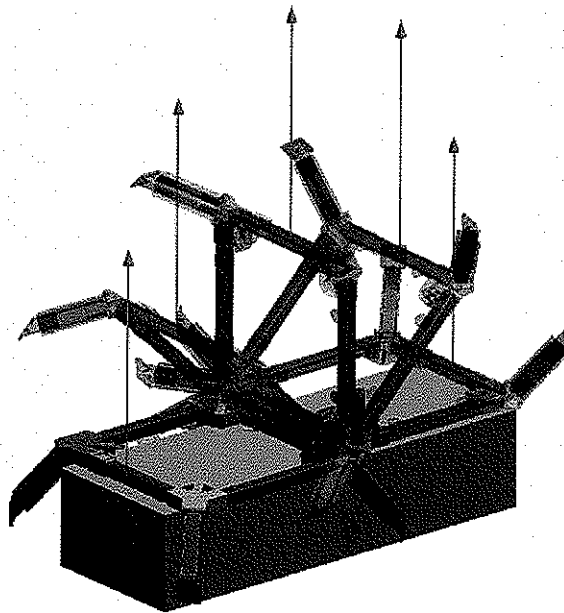

TFR-TRI WORK

Figure 4

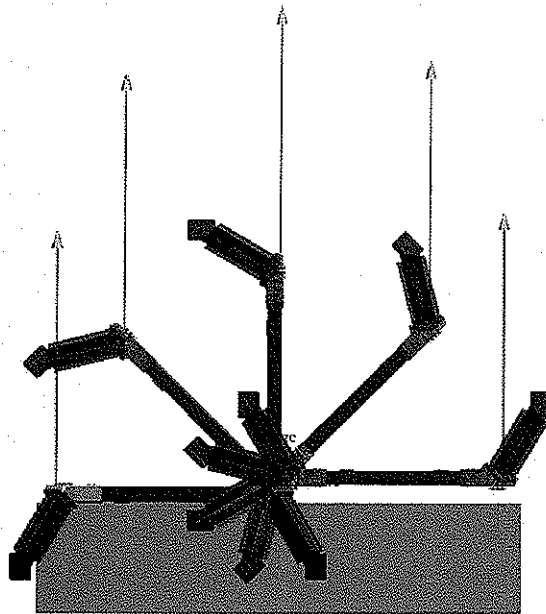

TFR-TRI WORK

Figure 5

13.

Attach the four straps to the four tubes on the LUSS, and reposition the LUSS for a more convenience match drilling process, if necessary.

JH
8.20.07

TASK PERFORMANCE SHEET
 CONTINUATION PAGE
 NASA - LYNDON B. JOHNSON SPACE CENTER

4. TPS NO. 2A0720178
 6. MOD NO.

20. OPER
 SEQ. NO.

21. OPERATIONS
 (Print, Type, or Write Legibly)

VERIFICATION

22. TECH 23. QA/DV

MATCH DRILLING PROCESS BEGINS

14. Per drawing Vertex Bracket Match Drill Assembly, SFG38119521-301 (GSE), install Vertex Bracket Drill Template Assembly, SEG38119522-301 (GSE), two (2) Vertex Bracket Shims, SDG38119525-001 (GSE), two (2) Aft Bracket Shims, SDG38119525-002 (GSE), by installing eight (8) bolts, NAS1351C6-12 (CI), Lot # _____, and washers, NAS1149E0632R (CI), Lot # _____. Apply thin layer of grease, Braycote 601EF, to the bolts thread prior to installation.

ESC
 TECH
 18
 8-21-07

Record Lot# 86440 Exp. Date 3-15-2026

15. Finger tight the fasteners in Step 14 at this time.

ESC
 TECH
 18
 8-21-07

16. Install two (2) counter-sink screws, NAS1102E06-14 (CI), Lot # _____, as seen in Figure 9. Apply thin layer of grease, Braycote 601EF, to the bolts thread prior to installation.

ESC
 TECH
 18
 8-21-07

Record Lot# 86440 Exp. Date 3-15-2026

17. Position the Vertex Bracket Drill Template Assembly, SEG38119522-301 (GSE), and tighten the two (2) counter-sunk screws until the template hole pattern lines up with the hole pattern on the LUSS as much as possible. WARNING: Do not over torque screws (50 in-lbs maximum) if the template cannot be moved any further.

ESC
 TECH
 18
 8-21-07

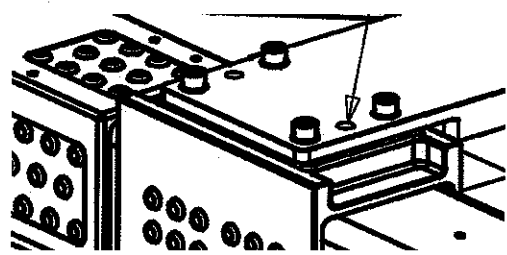
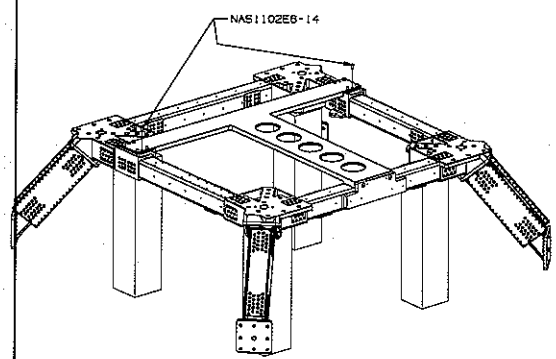

Figure 6

TASK PERFORMANCE SHEET
 CONTINUATION PAGE
 NASA - LYNDON B. JOHNSON SPACE CENTER

4. TPS NO. 2A0720178

6. MOD NO.

20. OPER
SEQ. NO.

21. OPERATIONS
(Print, Type, or Write Legibly)

VERIFICATION

22. TECH

23. QA/DV

MIP
7-30-07

18. Torque the eight (8) bolts, NAS1351C6-12 (CI) previously installed to the final torque of 51-62 in-lbs.

Bolts #	Final Torque
Joint 1:	
1.	<u>61.6</u>
2.	<u>61.6</u>
3.	<u>61.7</u>
4.	<u>61.7</u>
Joint 2:	
1.	<u>61.8</u>
2.	<u>61.7</u>
3.	<u>61.7</u>
4.	<u>61.8</u>

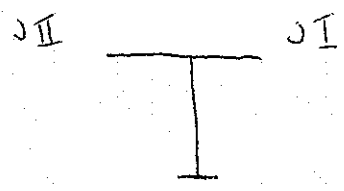

Final Torque: Record M# 230566 Cal Due Date 1/25/08



8-21-07 8-21-07

19. Install one (1) Drill Template Shim, SDG38119525-003 (GSE), one (1) Drill Template Peelable Shim, SDG38119526-001 (GSE).



8-21-07

20. Add or remove shims between Vertex Bracket Drill Template Assembly, SEG38119522-301 (GSE), and LUSS as necessary.



8-21-07

21. Clamp down the End Plate of the Vertex Bracket Drill Template Assembly, SEG38119522-301 (GSE), to the LUSS.



8-21-07

WARNING: Care must be taken to avoid damage to the flight hardware.

22. Using the portable Magnetic Drill, drill out the holes on the LUSS through the pilot holes on the Drill Template Assembly, per drawing SFG38119521-301 (GSE). Final hole size is .960 +/- .005.



8-21-07

23. Remove all fasteners and place them in the marked bag for identification.



8-21-07

24. Remove the Vertex Bracket Drill Template Assembly, and all shims.



8-21-07

25. Remove all burrs, debris, and sharp edges for holes on the LUSS per SFG38119521-301 (GSE).



8-21-07

26. Touch up the holes on the LUSS with Alodine Conversion Coat (Class 1A) per PRC-5005.



8-28-07

27. Close this TPS.