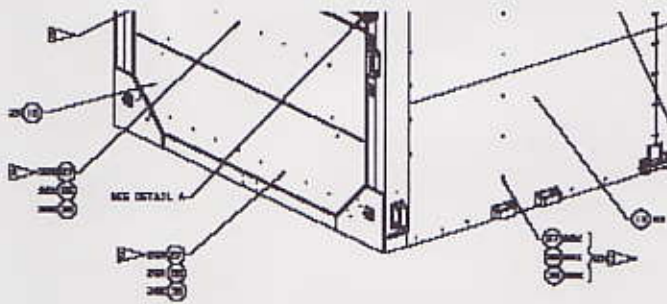

~ESCG~

1. PROJECT CODE		2. JPIC CODE		TASK PERFORMANCE SHEET				
SA-AMS		AMS		NASA - LYNDON B. JOHNSON SPACE CENTER				
3. TYPE	A	CONFIGURATION CHANGE		<input type="checkbox"/>	4. TPS NO. <u>2A0720030</u>	5. PAGE 1 OF 6		
	PERMANENT		<input type="checkbox"/>	TEMPORARY	<input type="checkbox"/>	6. MOD SHEET(S) NUMBER(S)	7. ORG.	8. SYSTEM
	B	NONCONFIGURATION CHANGE		<input checked="" type="checkbox"/>	MI	EA	N/A	
10. PART NAME				11. PART NO./DRAWING NO.		12. SERIAL/LOT NO.		
Upper USS-02/Payload Assy Shipping				SEG38116929		N/A		
14. APPLICABLE DOCUMENTS				15. CONTRACT NO./JOB NO.		16. HAZ TEST		
N/A				NNJ05HI05C		<input type="checkbox"/> YES <input checked="" type="checkbox"/> NO		
18. SHORT TITLE OF TPS							19. ADP UPDATE	
Removal of PSS panels and miscellaneous at CERN							<input type="checkbox"/> YES <input checked="" type="checkbox"/> NO	
20. OPER SEQ. NO.		21. OPERATIONS (Print, Type, or Write Legibly)				VERIFICATION		
		 1-24-07				22. TECH		
						23. QA/DV		
<p>1. Open this TPS.</p> <p>The Jacobs Project Engineer on site has the option to reorder steps in order to facilitate the logistics of moving around this large hardware.</p> <p>2. Ref Drawing SEG38116929. Remove all cover panels (items 13 thru 18) and associated fasteners, NAS1351N3LB12, item 27 in Figure 1, lock spring washers, MS35338-138, item 35, and flat washers, NAS1149E0332R, item 36. Place the fasteners in the marked bag for identification.</p> <div style="text-align: center;">  <p>Figure 1</p> </div>								
24. ORIGINATOR <u>JOE KASTELIC</u> Ken Q. Nguyen				DATE <u>1/24/07</u>		25. FINAL ACCEPTANCE STAMP AND DATE		
APPROVALS (Printed or Typed and Signed)								
26. PROJECT ENGINEER <u>JOE KASTELIC</u> Ken Q. Nguyen				DATE <u>1/24/07</u>		27. QUALITY ENGINEER <u>Steve Caldwell</u> DATE <u>1-24-07</u>		
28.				29.		ORIGINAL		
30.				31.		Return to Bldg. <u>10</u> Rm. <u>114</u> QARC		

TASK PERFORMANCE SHEET
 CONTINUATION PAGE
 NASA - LYNDON B. JOHNSON SPACE CENTER

4. TPS NO. 2A0720030

6. MOD NO.

20. OPER
SEQ NO

21. OPERATIONS
(Print, Type, or Write Legibly)

VERIFICATION

22. TECH 23. QADV

MIP
1
4-07

3. Install the lateral tie-bar assembly, SEG38117018-301, item 8 in Figure 2, along with 16 bolts, SDG38117090-801, and washers, NAS1587-8C. Record the locking torque and final torque per drawing SEG38117000.

Bolts #	Locking Torque	Final Torque
1.	65.1 in-lb	82 ft-lb
2. E	39.2 in-lb	81 ft-lb
3. :	75.0 in-lb	83 ft-lb
4. :	85.4 in-lb	83 ft-lb
5. :	85.4 in-lb	84 ft-lb
6.	32.2 in-lb	80 ft-lb
7.	52.7 in-lb	82 ft-lb
8.	34.8 in-lb	80 ft-lb
9.	74.0 in-lb	82 ft-lb
10.	66.4 in-lb	82 ft-lb
11.	37.0 in-lb	80 ft-lb
12.	74.3 in-lb	82 ft-lb
13.	64.6 in-lb	82 ft-lb
14.	59.8 in-lb	82 ft-lb
15.	54.5 in-lb	82 ft-lb
16.	45.6 in-lb	82 ft-lb

ESC
DY
18
2/13/07

Wrench PW 020360 (Running)
 Cert. Note M# 07/01-0280 Cal Due Date Jan. 30, 2007
 Wrench PW M214647 (Final)
 Note M# M214647 Cal due date 4/11/07

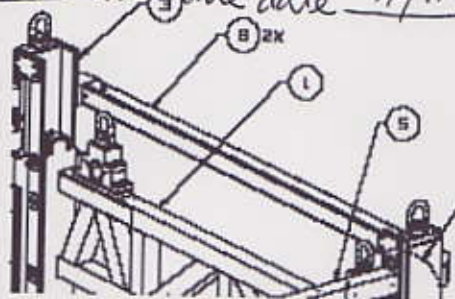

Figure 2

4. Remove two internal tie bars assemblies, SEG38117099, item 3 in Figure 3, along with their bolts, SDG38117090-801, item 29, and washers, NAS1587-8C, item 37. Place the fasteners in the marked bag for identification.

TASK PERFORMANCE SHEET
 CONTINUATION PAGE
 NASA - LYNDON B. JOHNSON SPACE CENTER

4. TPS NO. 2A0720030
 6. MOD NO.

20. OPER
 SEQ. NO.

21. OPERATIONS
 (Print, Type, or Write Legibly)

VERIFICATION

22. TECH 23. QA/DV

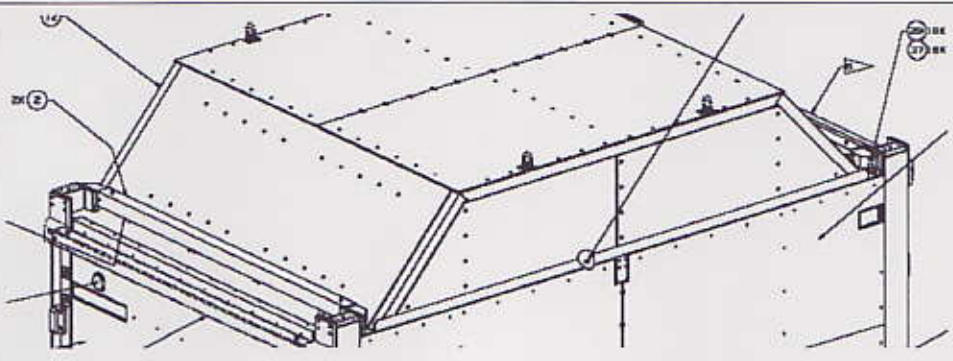

Figure 3

5. Remove the two Sliding Frame Cover Assembly, SEG38117068, item 11 in Figure 4, along with their bolts, NAS1351N4LB20, item 30 in Figure 3, flat washers, NAS1149E0432R, item 34, and lock spring washers, MS35338-139, item 38. Place the fasteners in the marked bag for identification.

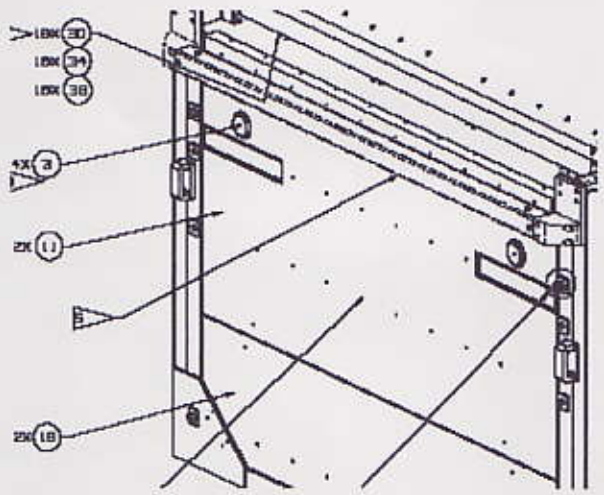

Figure 4

6. For the Cover Assembly, SEG38117057-301, item 12 in Figure 5, remove the bolts, NAS1958C70, item 28, countersink washers, NAS1587-8C, item 37, and self-locking nuts, NAS1291C8M, item 41. Place all fasteners in the marked bag for identification.

TASK PERFORMANCE SHEET
 CONTINUATION PAGE
 NASA - LYNDON B. JOHNSON SPACE CENTER

4. TPS NO. 2A0720030

6. MOD NO.

20. OPER
 SEQ. NO.

21. OPERATIONS
 (Print, Type, or Write Legibly)

VERIFICATION

22. TECH

23. QA/DV

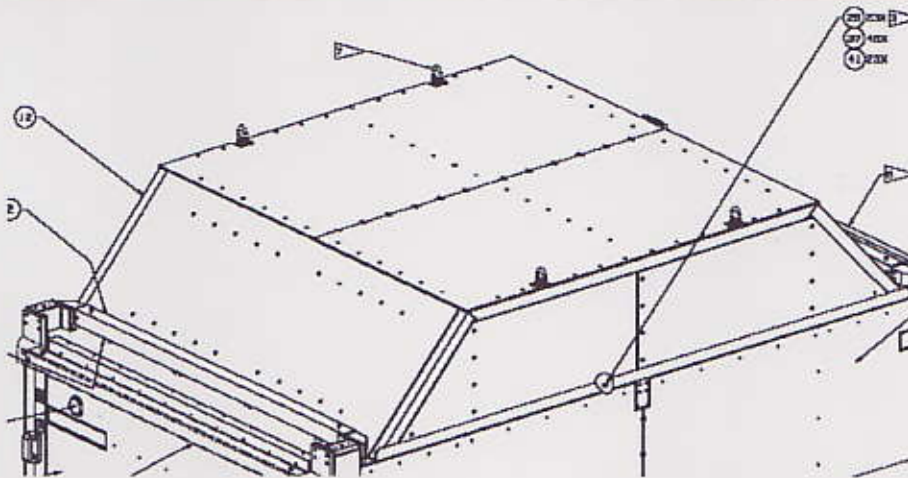

Figure 5

7. Remove the cover assembly, item 12 in Figure 5, using crane and straps that connect to the four swivel hoists rings on the cover.
8. Download the data from the shock writers per TPS# 2A0720019.
9. Cut the lock wire and remove the bolts, NAS1958C20H, item 5 in Figure 6, and countersink washers, NAS1587-8C, and remove all four trunnion block top assembly, SDG38117061-301, item 2, and all four top halves of trunnion block bushing, SDG38117012-001, item 3. Place the fasteners and bushings in the marked bag for identification.

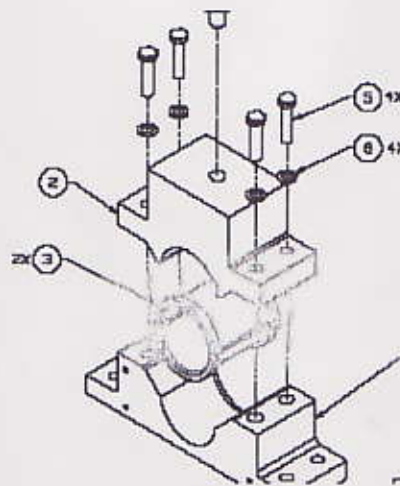

Figure 6

10. Remove the spacer block assemblies, SEG38117134-301, item 9 in Figure 7, by removing all fasteners in flag note 1. When the spacer block assemblies are out of the PSS, re-install the fasteners in flag note 1, and hand tight the fasteners.

TASK PERFORMANCE SHEET
 CONTINUATION PAGE
 NASA - LYNDON B. JOHNSON SPACE CENTER

4. TPS NO.

200720030

6. MOD NO.

20. OPER
SEQ. NO.

21. OPERATIONS
(Print, Type, or Write Legibly)

VERIFICATION

22. TECH

23. QADV

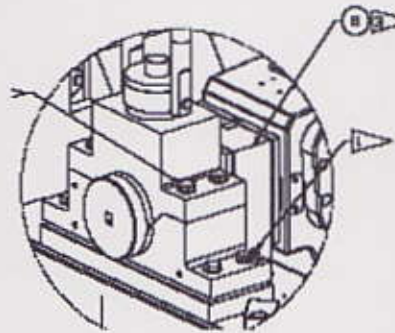

Figure 7

11. Carefully remove four Sill Trunnion Retainers, SDG38117023-001, item 3 in Figure 8. **Caution: Sill Trunnion retainer threads must be protected from any debris or mechanical damage.**

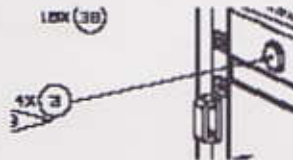

Figure 8

12. Remove Assembly Fixture interface bolts, NAS1958C25, item 32 in Figure 9, countersink washers, NAS1587-8C, item 37, and self-locking nuts, NAS1291C8M. Place the fasteners in the marked bag for identification.

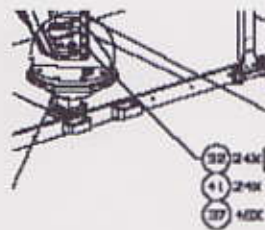

Figure 9

13. Remove the pedestal weldment A, SEG38117020-701, item 8 in Figure 10, pedestal weldment B, SEG38117020-702, item 6, pedestal weldment C, SEG38117020-703, item 7, along with their bolts, SDG38117090-801, item 29, and washers, NAS1587-8C, item 37, and also remove all the pedestal shims. Place the fasteners in the marked bag for identification.

TASK PERFORMANCE SHEET
 CONTINUATION PAGE
 NASA - LYNDON B. JOHNSON SPACE CENTER

4. TPS NO.

2A0720030

6. MOD NO.

20. OPER
SEQ. NO.

21. OPERATIONS
(Print, Type, or Write Legibly)

VERIFICATION

22. TECH

23. QA/DV

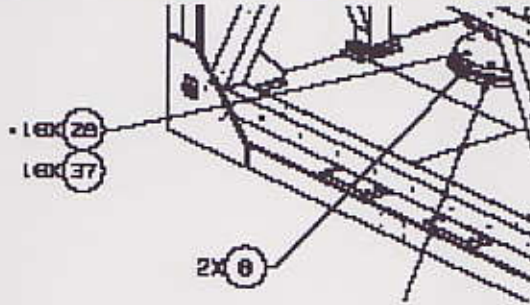

Figure 10

14. Close this TPS.

1. PROJECT CODE		2. JPIC CODE		TASK PERFORMANCE SHEET			
SA-AMS		AMS		NASA - LYNDON B. JOHNSON SPACE CENTER			
TYPE	3. A CONFIGURATION CHANGE <input checked="" type="checkbox"/>		4. TPS NO. 2A0720040		5. PAGE 1 OF 1		
	PERMANENT <input checked="" type="checkbox"/>	TEMPORARY <input type="checkbox"/>	6. MOD SHEET(S) NUMBER(S)		7. ORG.	8. SYSTEM	9. NEED DATE
	B NONCONFIGURATION CHANGE <input type="checkbox"/>		1		EA	N/A	2-8-07
10. PART NAME Upper USS-02/Payload Shipping			11. PART NO./DRAWING NO. SEG38116929		12. SERIAL/LOT NO. N/A		13. TIME/CYCLE/SHELF LIFE <input type="checkbox"/> YES <input checked="" type="checkbox"/> NO
14. APPLICABLE DOCUMENTS N/A			15. CONTRACT NO./JOB NO. NNJ05HI05C		16. HAZ. TEST <input type="checkbox"/> YES <input checked="" type="checkbox"/> NO		17. ENG. EVAL. <input type="checkbox"/> YES <input checked="" type="checkbox"/> NO
18. SHORT TITLE OF TPS Remove the Upper USS-02 from the PSS and into the RAS - Modification MI						19. ADP UPDATE <input type="checkbox"/> YES <input checked="" type="checkbox"/> NO	
20. OPER. SEQ. NO.		21. OPERATIONS (Print, Type, or Write Legibly)				VERIFICATION	
						22. TECH	23. QADV
1.		Open this MOD.					
2.		Replace Step 8 with this step: The Upper USS-02 is to be placed into the Rotation Assembly Stand, RAS, per AMS_sta_proc_1, provided by Robert Becker, CERN.					
3.		Close this MOD					
24. ORIGINATOR Ken Q. Nguyen <i>Ken Q. Nguyen</i>			DATE 2/3/07		25. FINAL ACCEPTANCE STAMP AND DATE		
APPROVALS (Printed or Typed and Signed)							
26. PROJECT ENGINEER Ken Q. Nguyen <i>Ken Q. Nguyen</i>			DATE 2/08/07		27. QUALITY ENGINEER Steve Caldwell		DATE
28.					29.		
30.					31.		